



Installation, use and
operation manual

Pro-WS⁴

D-EIMAH03806-25_01EN

› Pro-WS⁴

Translation of the original instructions

REV	01
DATE	January 2026
REPLACES	-

Contents

IMPORTANT WARNINGS	3
Purpose of the manual	3
Intended use of the unit	3
Safety regulations	4
Residual risks	6
SAFETY DEVICES	6
UNIT CHARACTERISTICS	7
Environmental conditions	7
Environmental contamination	7
Noise	7
Floor characteristics (for standard unit)	8
Wall characteristics	9
Technical data	9
Compartment clearance and operating pressure	10
Summary of unit operation	11
Supplied loose	13
RECEIPT OF THE PACKAGES	14
TRANSPORT	14
UNPACKING AND VERIFICATION OF INTEGRITY	16
After unpacking	16
Storage waiting for installation	17
INSTALLATION	18
Installation procedure	18
MAINTENANCE	45
Safety precautions for maintenance	45
Ordinary maintenance	46
Extraordinary maintenance	49
Disposal of used materials - waste	50
Diagnostics	50
Troubleshooting table	51
Repair log	52

1 Important warnings



The pictogram shows a situation of immediate danger or a dangerous situation that might cause injuries or death.



The pictogram shows that it is necessary to adopt suitable behaviour in order to avoid jeopardising staff safety and cause damages to the equipment.



The pictogram shows particularly important technical information that should be taken into consideration by the people installing or using the equipment.

Purpose of the manual

The purpose of this **manual** is to guide the installer and qualified operator in the installation, maintenance and proper and safe use of the equipment. For this reason, **it is mandatory for all personnel involved in installation, maintenance and supervision of the unit to read this manual.**

Contact the Manufacturer if any points are unclear or difficult to understand.

This manual contains information regarding:

- technical specifications of the unit;
- instructions for transport, handling, installation and assembly;
- use;
- information for instructing personnel authorised for its use;
- maintenance.

All the information provided generally refers to any unit of the Pro-WS range. All units are shipped together with a **technical drawing**, indicating the specific weight and size of the unit received. It must be considered an integral part of this manual, and therefore it must be kept with the utmost care in all its parts.

If the manual or drawing is lost, it is important to request a copy from the Manufacturer, specifying the unit's serial number that can be found on the label on the unit itself.

In the case of divergent information between this manual and the drawing, the drawing will prevail.

Intended use of the unit

This appliance has the function of treating the air intended to condition data centers. Any other use is not in accordance with the intended use and therefore dangerous.

This range of units is designed to be used in NON-explosive environments.

This range of units is designed for installation inside buildings.

If the unit is used in critical situations, by type of system or environmental context, the customer must identify and adopt the technical and operational measures to avoid damage of any kind.

Safety regulations

SKILLS REQUIRED FOR THE INSTALLATION OF THE UNIT



Installers must perform operations according to their professional qualifications: all activities not within one's expertise (i.e., electrical connections) must be carried out by specialised and qualified staff so as not to endanger one's safety and the safety of the other operators interacting with the unit.



Equipment transport and handling operator: authorised person with recognised expertise in using transport and lifting equipment.



Technical installer: expert technician, sent or authorised by the manufacturer or its representative, with adequate skills and training to install the unit.

Assistant: technician subject to care obligations while lifting and assembling the equipment. He must be suitably trained and informed about the operations to perform and the safety plans of the site/installation location.

SKILLS REQUIRED FOR THE USE AND MAINTENANCE OF THE UNIT



Generic operator: AUTHORISED to run the unit using commands placed on the keypad of the electrical panel. Performs only unit control operations, power on/off.

Maintenance mechanic (qualified): AUTHORISED to carry out maintenance, adjustments, replacement and repair of mechanical parts. It must be a person competent in mechanical systems, therefore able to perform mechanical maintenance in a satisfactory and safe manner, must possess theoretical preparation and manual experience. NOT AUTHORISED to work on electrical systems.

Manufacturer's technician (qualified): AUTHORISED to perform complicated operations in every situation. Operates in accordance with the user.



Maintenance electrician (qualified): AUTHORISED to perform service of an electric nature, adjustments, maintenance and electrical repairs. AUTHORISED to operate in the presence of an active electrical connection inside the electrical panels and junction boxes. It must be a person competent in electronics and electrical engineering, therefore able to work on electrical systems satisfactorily and safely, must possess theoretical knowledge and proven experience. NOT AUTHORISED to work on mechanical systems.



Installers, users and maintenance technicians CANNOT work on the unit if they:

- are without experience and responsibility or minors;
- are in inadequate psycho-physical conditions;
- do not master the operating cycle of the unit;
- have not attended theoretical/practical training alongside an expert unit operator or user, or alongside a Manufacturer's technician.



Read this manual carefully before unit installation and maintenance and keep it for any further future consultation by the various operators. Do not remove, tear out or rewrite any part of this manual.



Failure to follow these instructions may cause damage and injuries, even fatal, voids the warranty and relieves the Manufacturer of all liability.



All installation, assembly, electrical connections to the mains and ordinary/extraordinary maintenance must be performed **only by technicians complying with the legal requirements**, after turning off the unit and using personal protective equipment (i.e., gloves, protective goggles, etc.), in compliance with the regulations in force in the country the equipment is to be used in and the laws on safety in the workplace.



Installation, use or maintenance other than those specified in the manual may cause damage, injury or death, invalidate the warranty and relieve the Manufacturer of all liability.



Use protective clothing and suitable equipment while handling or installing the equipment, in order to prevent accidents and safeguard your own and other people's safety. Individuals not assigned to installation or maintenance are NOT allowed to stand or pass through the work area while the unit is assembled.



Before carrying out any installation or maintenance, disconnect the equipment from the power supply and wait at least 120 seconds before carrying out any operation.



Before installing the equipment, check that the systems are in compliance with the regulations in force in the country of use and as indicated on the serial number plate.



It is the responsibility of the user/installer to check the static and dynamic stability relative to the installation and to arrange environments so that **people who are not competent or authorised DO NOT have access to the unit or to its commands.**



It is the responsibility of the user/installer to make sure that **weather conditions** do not affect the safety of persons and property during installation, use and maintenance.



Make sure the air intake is not located near any drains, flue-gases or other contaminating elements.



Do NOT install the equipment in places exposed to strong winds, salt air or open flames.



After installation is complete, instruct the user on the correct use of the unit. If the equipment does not work or functional or structural alterations are noted, disconnect it from the power supply and contact a service centre authorised by the Manufacturer or Retailer, without attempting to repair it on your own. For any replacements request the use of original spare parts.

Unauthorised actions, tampering or modifications that do not follow the information provided in this manual can cause damage, injuries or fatal accidents and void the warranty.

The serial number plate on the unit provides important technical information, essential in case of unit maintenance or repairs. We recommend that you do not remove, damage or modify it.



In order to ensure correct and safe conditions of use, we recommend you have the unit maintained and checked at least annually by a service centre authorised by the Manufacturer or Dealer.

Maximum acceptable humidity for installation: 25 to 65% RH non-condensing.

Residual risks

Despite having implemented and adopted all the safety measures indicated by applicable regulations, some residual risks remain. In particular, in some operations of replacement, adjustment and tooling maximum attention is always required in order to work in the best possible conditions.

LIST OF OPERATIONS WITH RESIDUAL RISKS

Risks for qualified personnel (electricians and mechanics):

- handling - during unloading and handling it is necessary to pay attention to all the steps listed in this manual regarding the points of reference;
- installation - during installation it is necessary to pay attention to all the steps listed in this manual regarding the points of reference. Moreover, the installer must ensure the static and dynamic stability of the unit's site of installation;
- maintenance - during maintenance it is necessary to pay attention to all the steps listed in this manual, and in particular to high temperatures that may be present in the heat transfer fluid lines to/from the unit;
- cleaning - the unit must be cleaned only when it is switched off, by turning off the switch installed by the electrician and the switch located on the unit itself. The key for interrupting the power supply must be kept by the operator until the end of the cleaning operations. Internal cleaning of the unit must be carried out using the protections required by current regulations. While the inside of the unit does not contain particular hazards, it is necessary to pay the utmost attention so that accidents do not occur during cleaning. The heat exchange coils that have a potentially sharp finned pack must be cleaned using suitable protective goggles and gloves. During adjustment, maintenance and cleaning there are residual risks of variable entity. Being operations that must be performed with guards disabled, it is necessary to pay particular attention in order to avoid damage to persons and things.
- Before performing any start-up, shutdown, maintenance, or adjustment operation, the operator must ensure that no person is within 1 meter of any hazardous parts of the machine, including areas where moving components are present.



Always pay close attention when performing the operations specified above. Remember that these operations must always be performed by authorised personnel.

All work must be completed in accordance with the legal provisions relating to work safety. Remember that the unit in question is an integral part of a larger system that includes other components, depending on the final characteristics of realisation and the mode of use. Therefore, in the end it is the responsibility of the user and assembler to assess the residual risks and their respective preventive measures.

SAFETY DEVICES



The unit is equipped with safety devices to prevent risks of damage to persons and for proper operation. Always pay attention to the symbols and safety devices on the unit. It should **only** operate with the safety devices engaged and with fixed or movable guards installed correctly and in the proper position.



If during installation, use or maintenance the safety devices have been temporarily removed or disabled, the unit can be operated **exclusively** by the qualified technician who made this change. It is **mandatory** to prevent other people's access to the unit. When finished, restore the devices to their proper status as soon as possible.

2 Unit characteristics

Pro-WS units are single-flow air handling units with ISO COARSE 55% filter, 98 mm panels with polyurethane insulation and water heat exchanger.

Environmental conditions



This unit is classified as IP00 and must be installed indoors, inside a protected environment. The unit cannot operate in environments containing explosive material and with a high concentration of dust.



Operating environment temperature	from -5 °C to 46 °C
Ambient temperature with the machine off (e.g. storing, handling, etc.)	from -40 °C to 60 °C
Operating environment relative humidity	from 25% to 65% RH
Protection degree	IP00

Environmental contamination

Depending on the installation operating environment, specific regulations must be followed and all the necessary precautions must be taken to avoid environmental issues (a system that operates in a hospital or chemical environment can have problems different from those in other sectors, even from the point of view of disposal of consumable parts, filters, etc.).

It is mandatory for the buyer to inform and train workers regarding proper procedures.

Noise



The units have been designed and manufactured in such a way as to produce sound emissions below the threshold of **80 dB(A)**. For the unit described in this manual, the measured sound power level in the vicinity of the machine is 75 dB(A).

It is important to note that each environment has its own acoustic characteristics, which can significantly influence the perceived sound pressure levels during operation. Therefore, the noise data provided should be considered as reference values only; it is the responsibility of the purchaser to carry out specific sound measurements at the installation site and under the actual operating conditions of the unit.

All personnel involved in installation, operation, and maintenance activities are strongly advised to use appropriate hearing protection devices, in accordance with applicable regulations.

Room characteristics

Floor characteristics (for standard unit)

The **floor** where you plan to position the unit **must** be:

- perfectly flat and without any roughness;
- vibration resistant;
- able to **support the weight of the equipment considering an appropriate safety margin** (see the following technical data table).

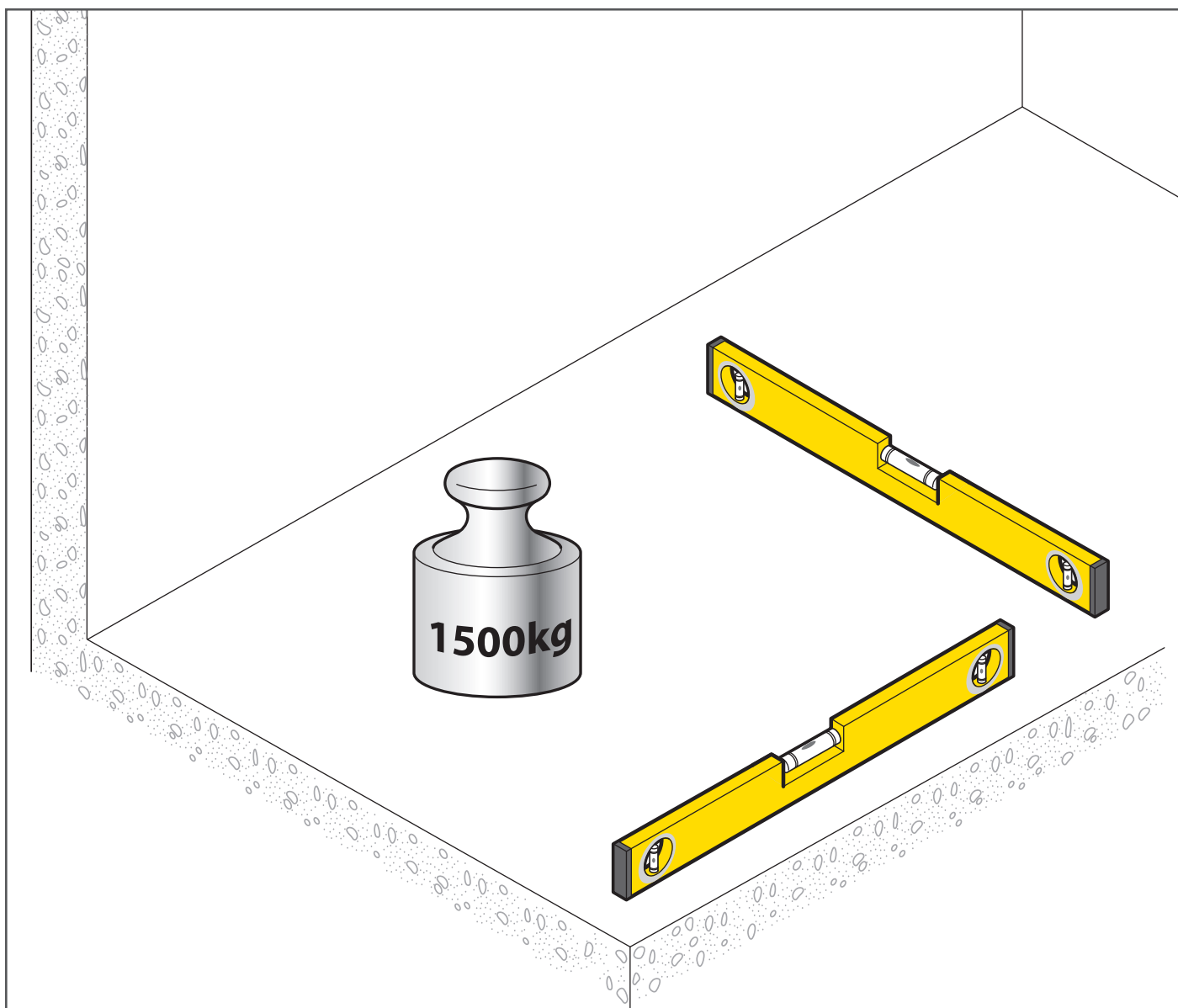

***Please see the weight table in the Technical data section for the load details.**

Wall characteristics

The wall on which the machine will be installed must be prepared with holes of the sizes indicated in the picture below:

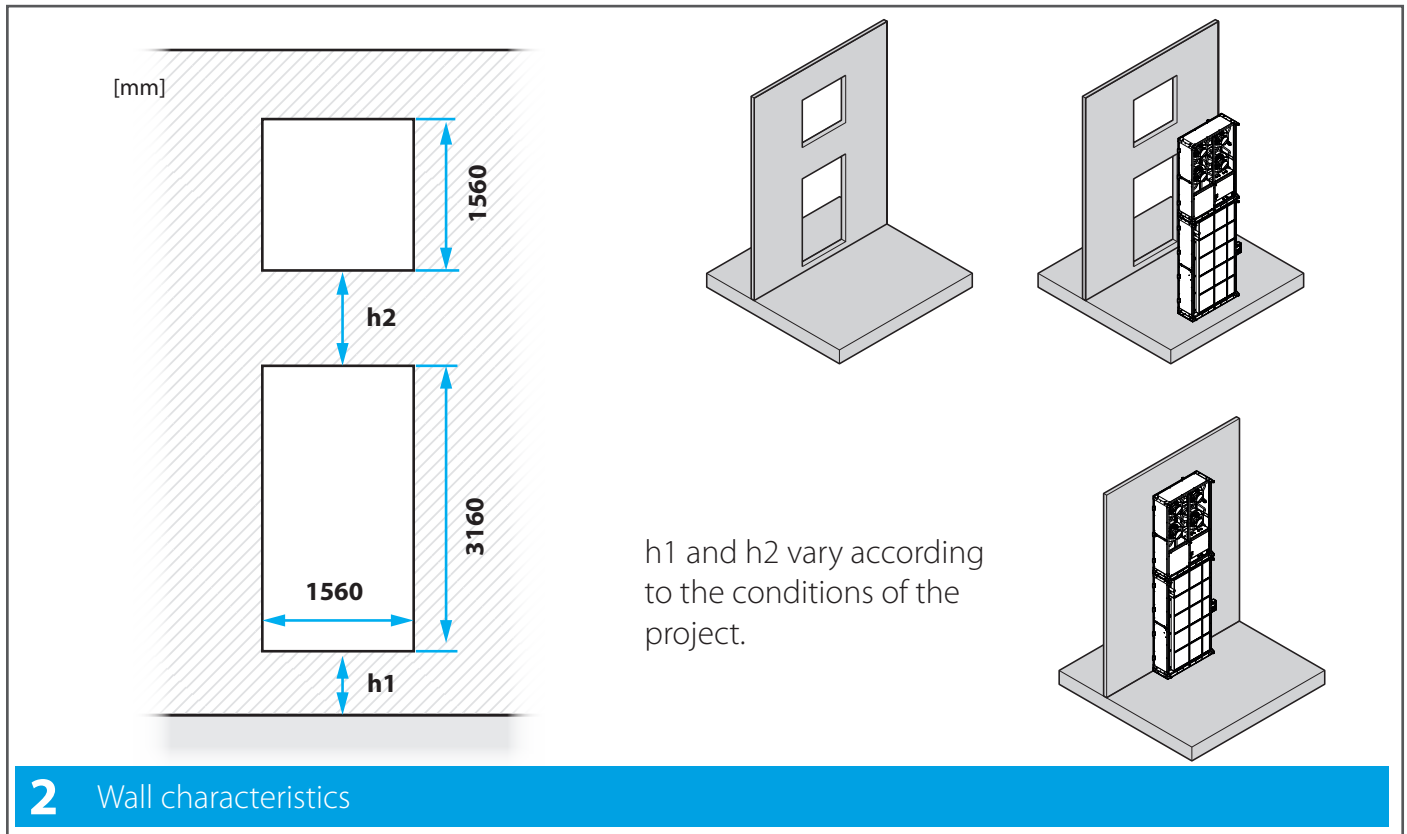

Technical data

NOMINAL TECHNICAL DATA TABLE	u.m.	
Nominal air flow rate	m ³ /h	38800
Coil thermal power	kW	159
FLA	A	23.3
FLI	W	6400
Electrical connection	V	400V, 3ph, 50Hz

WEIGHT TABLE	u.m.	
Gross weight with packaging	kg	1445 (960+485)
* Device weight	kg	1285 (870+415)
* Coil fluid weight	kg	165
Filter weight	kg	2.2 - 1.46 - 0.73
Fan weight	kg	50

The weights shown in the tables represent the maximum possible weight of the unit in its most complete configuration. The actual weight of the delivered unit may be lower, depending on the selected configuration (accessories, options, construction variants). For accurate and up-to-date weight information, always refer to the technical documentation supplied with the unit upon delivery.

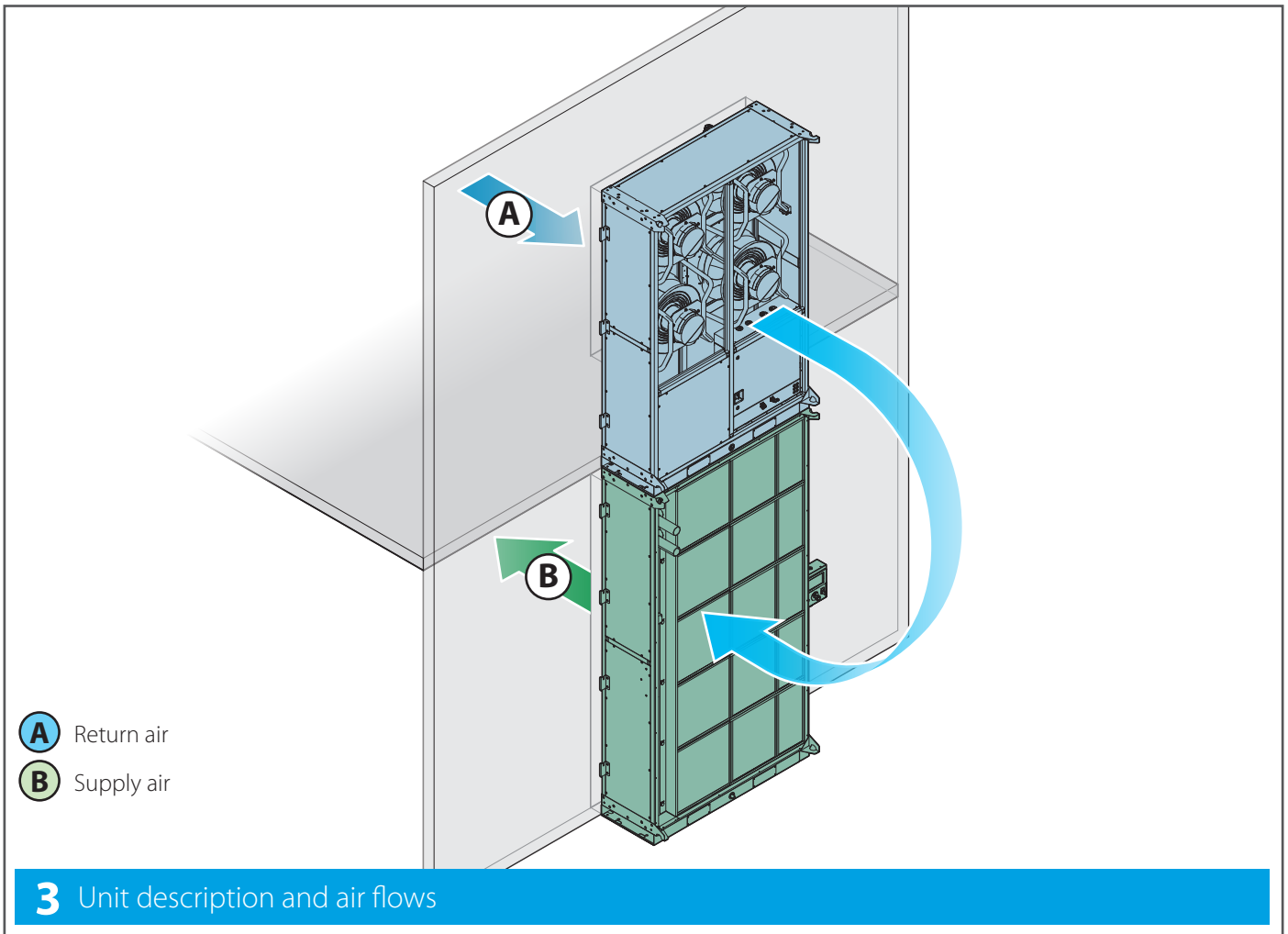

Compartment clearance and operating pressure

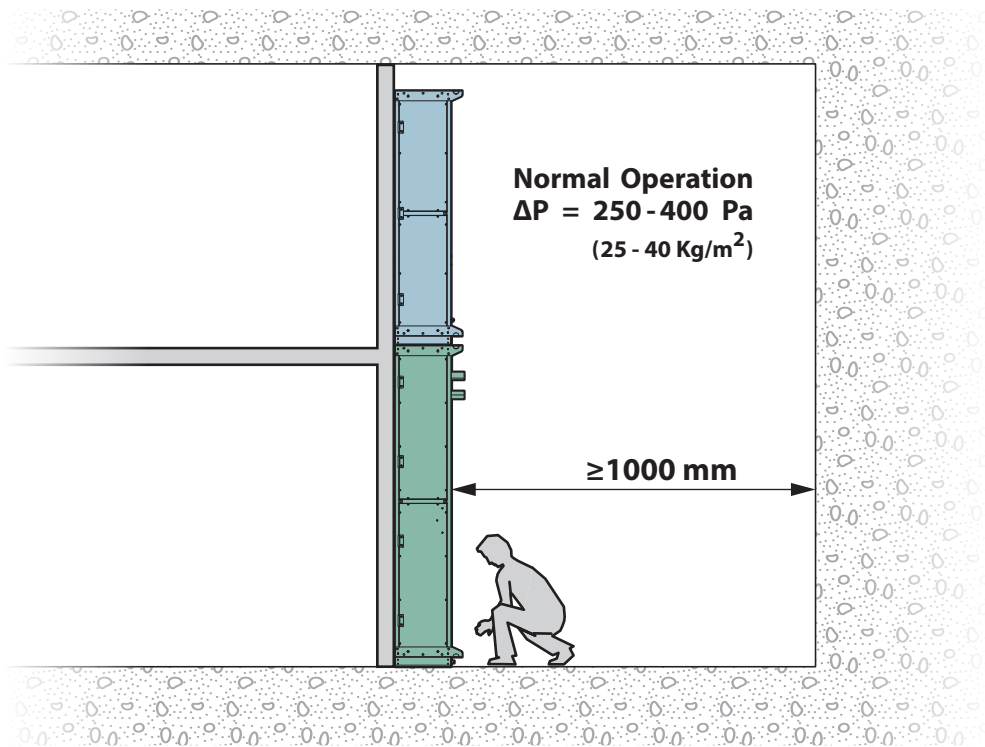

Make sure to leave at least 1000 mm in front of the unit for servicing.

During normal operation, the compartment reaches a pressure ranging from 250 to 400 Pa relative to ambient conditions.

Summary of unit operation

5 LEGEND

- ① Fans
- ② Electrical Panel
- ③ Temperature & humidity probe (supplied loose)
- ④ Basement
- ⑤ Pressure Transmitter

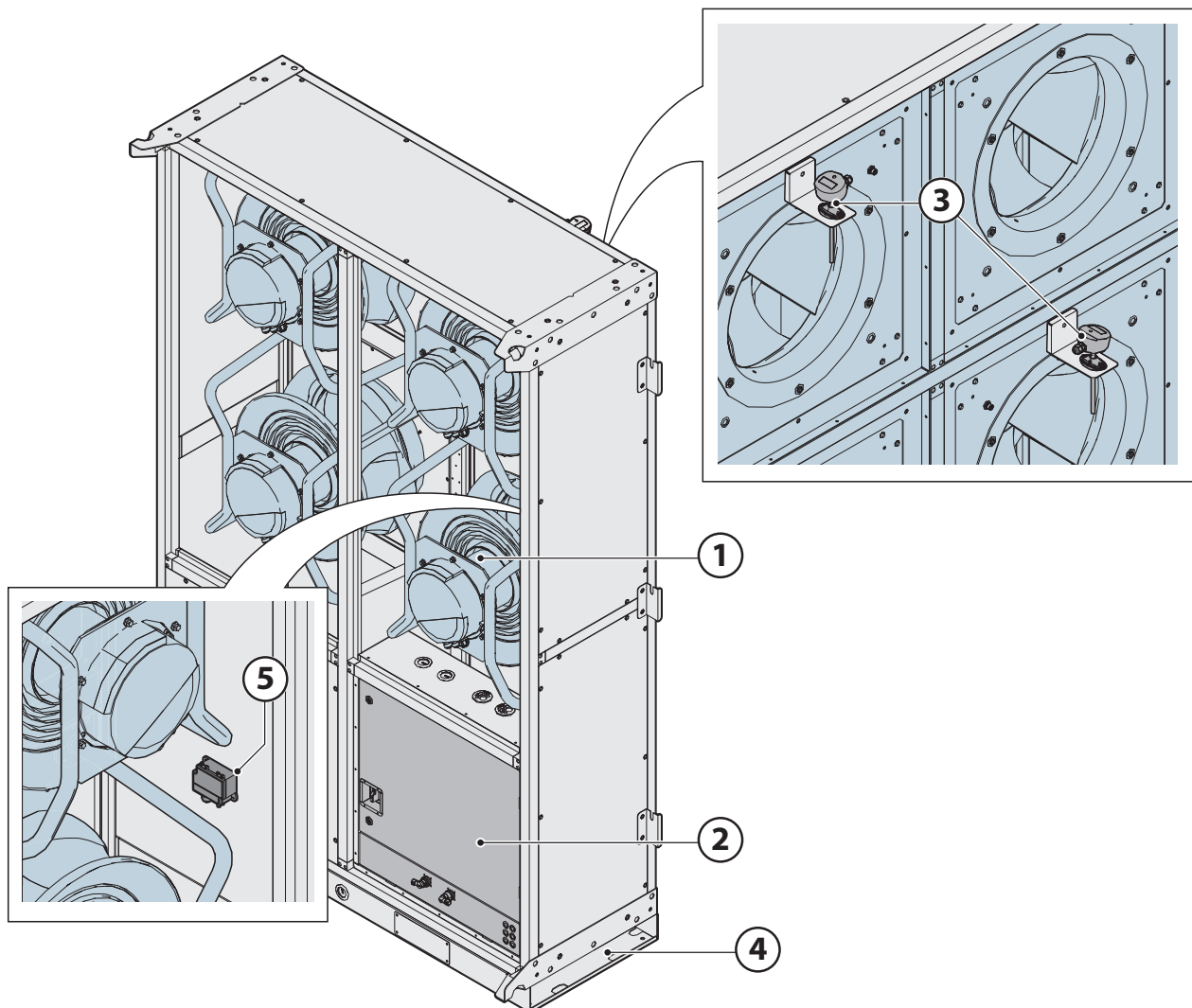

4 Fan section description

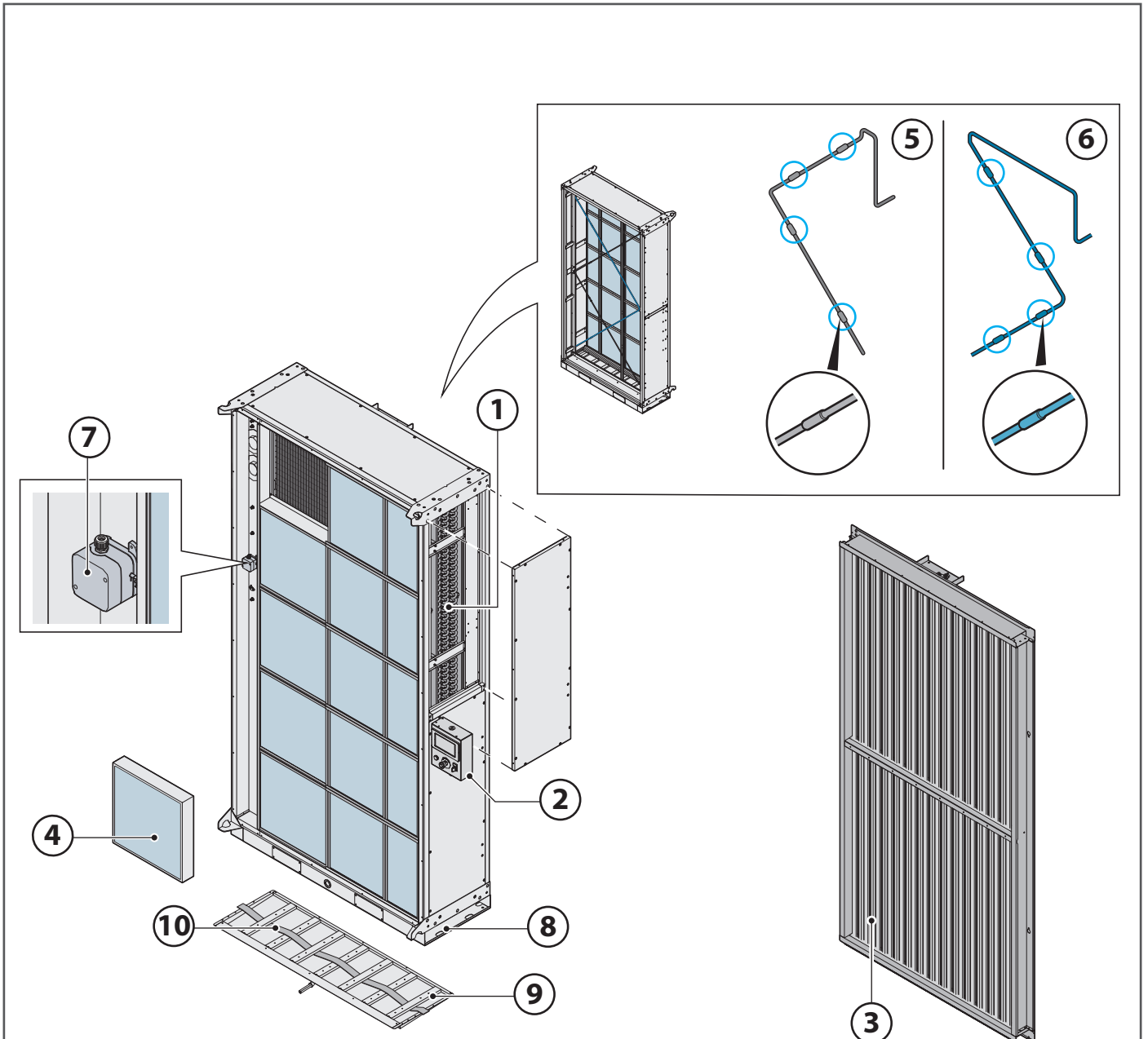

5 LEGEND

- ① Coil
- ② Remote Controller
- ③ Damper
- ④ Filters
- ⑤ Temperature probe SUPPLY TEMP NTC L1
- ⑥ Temperature probe SUPPLY TEMP NTC L2
- ⑦ Pressure Switch
- ⑧ Basement
- ⑨ Drain Pan
- ⑩ Flood Detector

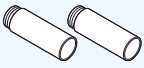

5 Coil section description

Supplied loose

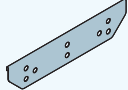
Component	Daikin PN	Quantity	Image
Actuator	AHAT-MO-SF24AS2+CONN	1	
Temperature and humidity probe	AHQE-TH-DUCT	2	
Energy Valve	See note below*	1	
Fitting Inlet	See note below*	See note below**	
Fitting Outlet	See note below*	See note below**	
Control box	N/A	1	
Wall fixing brackets	N/A	7 right / 7 left	
Extended coil pipes	See note below*	1	
Pressure transmitter 250	AHQEAIRDPT0-250	2	
Section fixing bracket	N/A	2	
Actuator brackets & damper pin	N/A	1	
Base opening locking plate	N/A	8	
Gasket	AHGU15X03P1GPA15X03	30 mt.	
Ferrite75	N/A	2	
Fasteners	N/A	2	

* The part number (PN) indicated depends on the specific configuration of the selected unit. To confirm the correct PN, always refer to the technical documentation supplied with the unit upon delivery.

** The quantity indicated depends on the specific configuration of the selected unit. To confirm the exact quantity, always refer to the technical documentation supplied with the unit upon delivery.

3 Receipt of the packages



Handle the equipment following the Manufacturer's instructions on the packaging and in this manual.

Always use personal protective equipment.

The means and method of transport must be chosen by the transport operator according to the type, weight and size of the unit. If necessary, draw up a "safety plan" to guarantee the safety of the people directly involved.

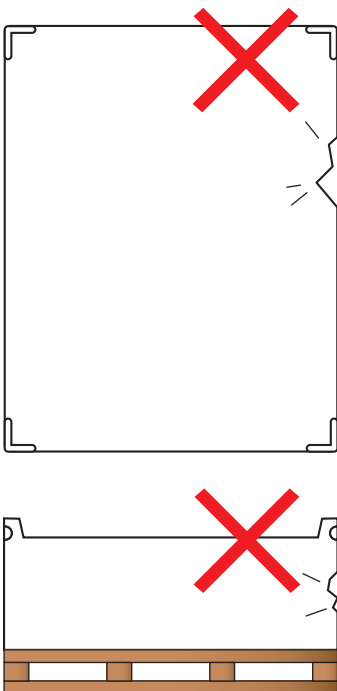

Upon receipt of the unit check the integrity of the packaging and the amount of packages sent:

A) there is visible damage/missing packages: **do not** proceed with the installation, but **immediately** notify the manufacturer and the carrier who made the delivery.

Alternatively you can accept the shipment "subject to verification": this will make it possible to open the cartons and check if the internal components are indeed damaged. In the latter case, as noted previously, **promptly** notify the Manufacturer and the carrier that made the delivery.

Before opening the packages, it is recommended to take good quality pictures to document the damage.

B) There is NO visible damage: move the unit to the site of installation.

4 Transport



The packages must be transported with a transpallet or a forklift, suitable for the weight and size of the package. The choice of the most appropriate means and way remains the responsibility of the transport operator.

The figure **6** on the next page shows the correct forking direction of the unit according to the size and sections; always make sure to keep the centre of gravity of the load balanced.



The operating area must be perfectly free from objects or people not involved in the transport.



Transport the equipment carefully, in perfect psycho-physical shape, avoiding sudden manoeuvres and equipped with personal protective equipment (gloves, safety shoes, etc.).



It is forbidden to transport a coil section and a fan section at the same time

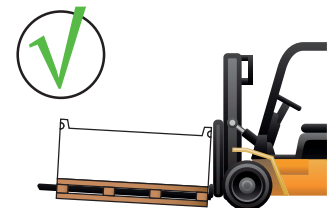
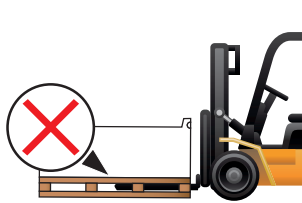
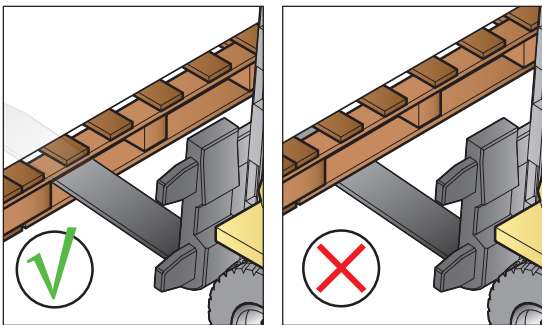
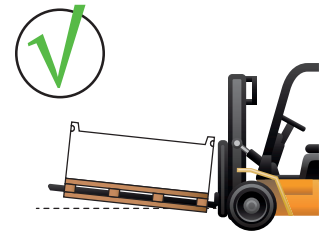
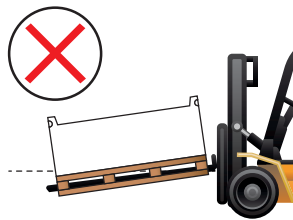
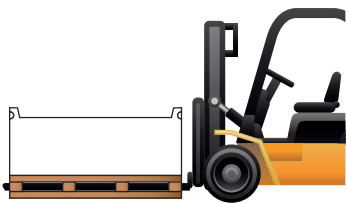
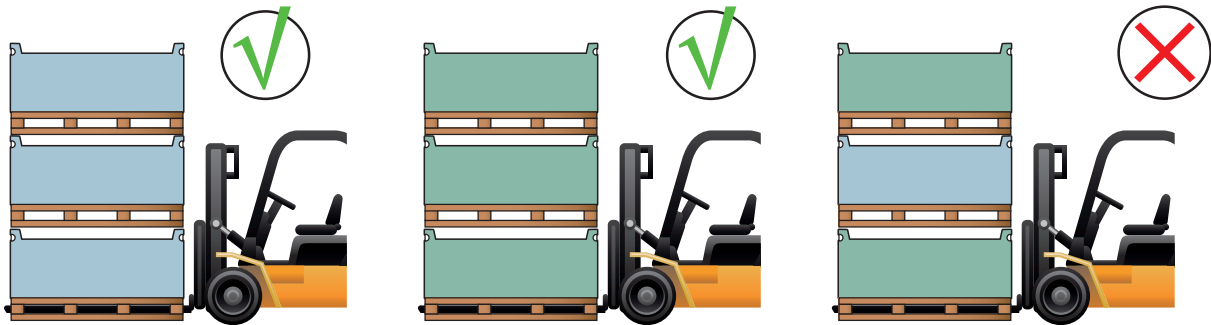

Lift the unit by inserting the forks into the holes provided in the base support.

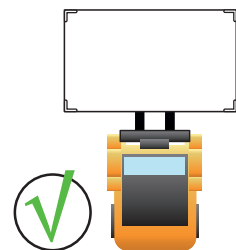
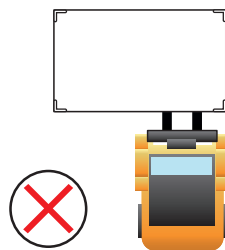

6 Correct transport of the packed unit

5 Unpacking and verification of integrity

We recommend the equipment be unpacked after moving it to its installation location and only when it is to be installed. This operation must be performed using personal protection equipment (i.e., gloves, safety shoes, etc.).



Do not leave the packing unattended: it is potentially harmful to children and animals (suffocation hazard).



Some packing materials must be kept for future use (wooden crates, pallets, etc.), while those that cannot be reused (i.e., polystyrene, strapping, etc.) must be disposed of in compliance with the regulations in force in the country of installation: this will protect the environment!

After unpacking

After unpacking, check the received contents:

- **Installation and operation manual (IOM)**
- **Wiring diagram**
- **Declaration of conformity**







Check therefore that you have received all the components and that they are undamaged.

In case of damaged or missing parts:

- **do not move, install or repair** damaged components and the unit in general.
- **take quality photos** to document the damage.
- **find the serial number plate** on the unit and note the unit's serial number.
- **immediately** notify the carrier that delivered the unit.
- **promptly** contact the Manufacturer (keep available the serial number of your unit).



Please note that complaints or claims of damage reported after 10 days of receipt of the unit cannot be accepted.

DAIKIN		Data Date	E	XXXXXX
AHU	Part no.	XXXXXX		
Modello Model	D	XXXXXX	Matricola Serial number	C
PORTATA ARIA / AIR FLOW		XXXXXX		
Mandata Supply fan	F	XXXXXX m ³ /h	   	
Motore Motor	XXXXX kW XXX A		  	
Corrente / Current Voltaggio / Voltage	XXXX A		G	
MESSA IN FUNZIONE All'avviamento consultare il manuale operative e controllare		START UP Before the start up read carefully the operating instruction manual and check:		
1) senso di rotazione del ventilatore		1) fan rotation direction		
2) l'assorbimento del motore, il quale non deve superare il valore di targa sopraindicato		2) the current input must not exceed the value mentioned on the above tag		
A DAIKIN APPLIED EUROPE S.p.A. Via Piani di Santa Maria, 72 00072 Ariccia - (ROMA) IT				

- A: Manufacturer's name and data
DAIKIN APPLIED EUROPE S.P.A.
Via Piani di Santa Maria, 72 - 00072 Ariccia (Roma) - Italy
Tel: (+39) 06 93 73 11 - Fax: (+39) 06 93 74 014
- B: CE marking
- C: Unit serial number
- D: Model
- E: Date of manufacture
- F: Supply air flow rate
- G: Electrical specifications (frequency, number of phases, absorption in plate conditions)

Storage waiting for installation

7 Waiting for the installation, the components of the unit and the relative documents must be stored in an area that:

- is dedicated exclusively to the storage of the units.
- is protected from the weather (preferably prepare a closed area), with adequate temperature and humidity.
- is accessible only to operators tasked with the assembly.
- can support the weight of the equipment (check the load rating) and has a stable floor.
- is free from other components, especially if they are potentially explosive/incendiary/toxic.

If you cannot proceed with the installation straight away:

- check periodically that the above-mentioned conditions about the storage area are guaranteed.
- cover the unit with a sheet.
- always provide an insulating base (e.g., wood blocks) between the floor and the unit itself.

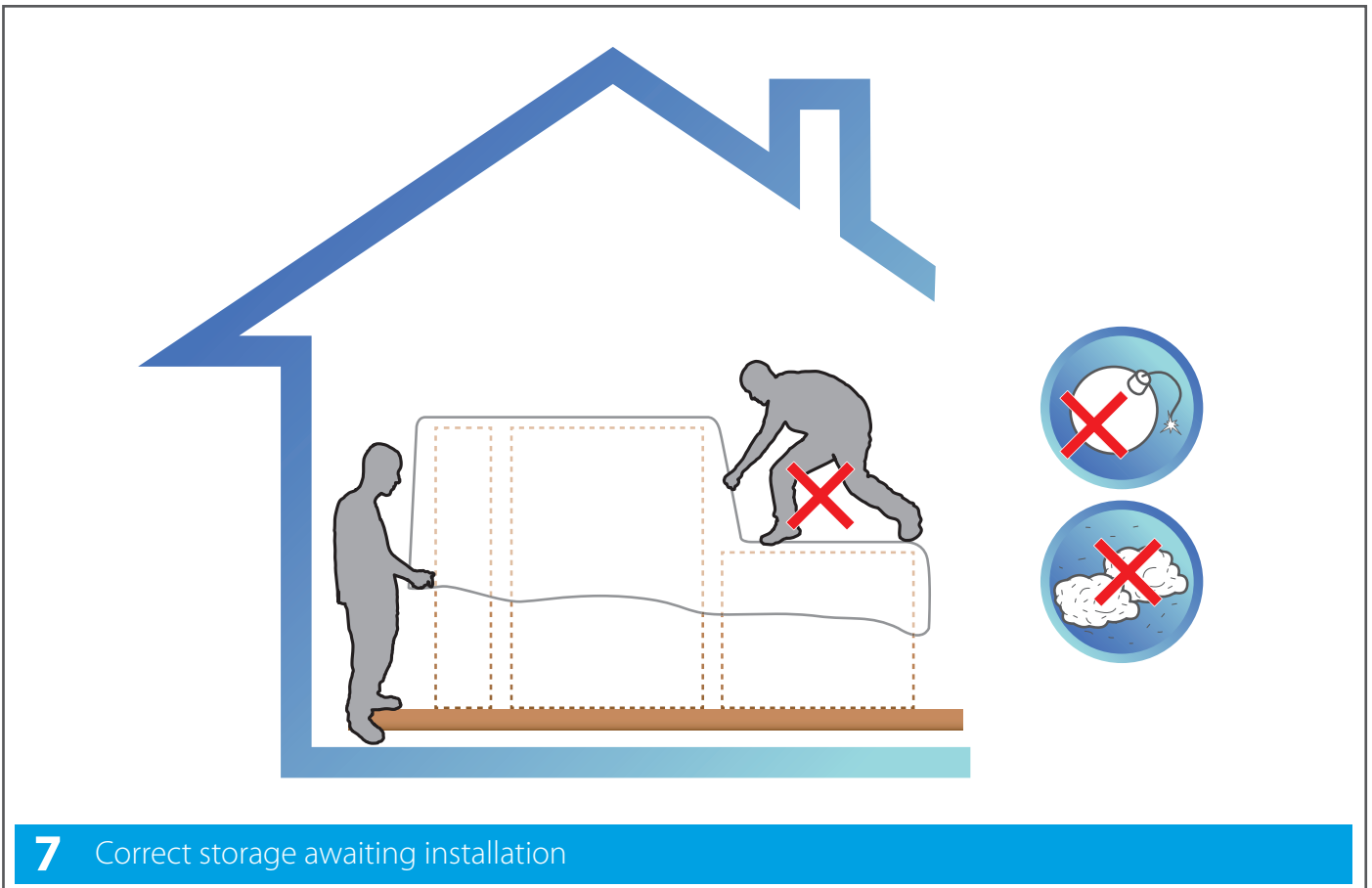

Any movement carried out after unpacking must be done with the doors closed. Do not move the units by pulling on the doors, if present, the uprights or other protruding parts that are not an integral part of the structure.



Do not step on the units!



6 Installation



All installation, assembly, electrical connections to the power supply and extraordinary maintenance must be performed **only by qualified personnel authorised by the Retailer or Manufacturer**, in compliance with the regulations in force in the country the equipment is to be used and the standards on the systems and safety in the workplace.



During installation, the area must be free from people and objects not used for the assembly.



Before starting, make sure you have all the necessary equipment.

Use only equipment that is in good condition and undamaged.



Maximum installation altitude: The altitude of the installation room must be less than 1,000 meters above sea level (at higher altitudes the electric motors deliver powers lower than the nominal ones)



Installation procedure

Before installation, read the safety instructions on the first pages of this manual. Contact the Manufacturer if any points are unclear or not perfectly understandable. A check mark next to each step will help to confirm complete and proper installation.



PHASE 0: TRANSPORT OF THE UNITS TO THE PLACE OF INSTALLATION



PHASE 1: CHECKING THE UNIT AND THE ARRANGEMENTS



PHASE 2: UNIT ASSEMBLY



PHASE 3: ELECTRICAL CONNECTIONS



PHASE 4: CONNECTION TO A DRAIN



PHASE 5: COIL CONNECTION



PHASE 6: COMMISSIONING ACTIVITIES

After installation store this manual and the assembly sheet that accompanied the unit in a place that is dry and clean. This way it will be accessible to operators in the future who need to consult it.

Do not remove, tear out or write on any part of this manual, besides the spaces set out for notes:

PHASE 0: TRANSPORT OF THE UNITS TO THE PLACE OF INSTALLATION

Transport the units until they reach the place intended for installation.



The units must be transported with a transpallet or a forklift, suitable for the weight and size of the package. The choice of the most appropriate means and way remains the responsibility of the transport operator.

The figure **8** below shows the correct forking direction of the unit according to the size and the sections; always make sure to keep the centre of gravity of the load balanced.



The operating area must be perfectly free from objects or people not involved in the transport.



Transport the equipment carefully, avoiding sudden manoeuvres and equipped with personal protective equipment (gloves, safety shoes, etc.).

It is forbidden to transport a coil section and a fan section at the same time

Lift the unit by inserting the forks into the holes provided in the base support.

8

Correct transport of the unit

PHASE 1: CHECKING THE UNIT AND THE ARRANGEMENTS

Check that the following have been planned at the installation site:

- (A) an **electrical system** compliant with current regulations and with specifications that meet the needs of the unit;
- (B) input water
- (C) output water
- (D) air vent
- (E) **water drain, with siphon**, connected to the sewer system;
- (F) water discharge

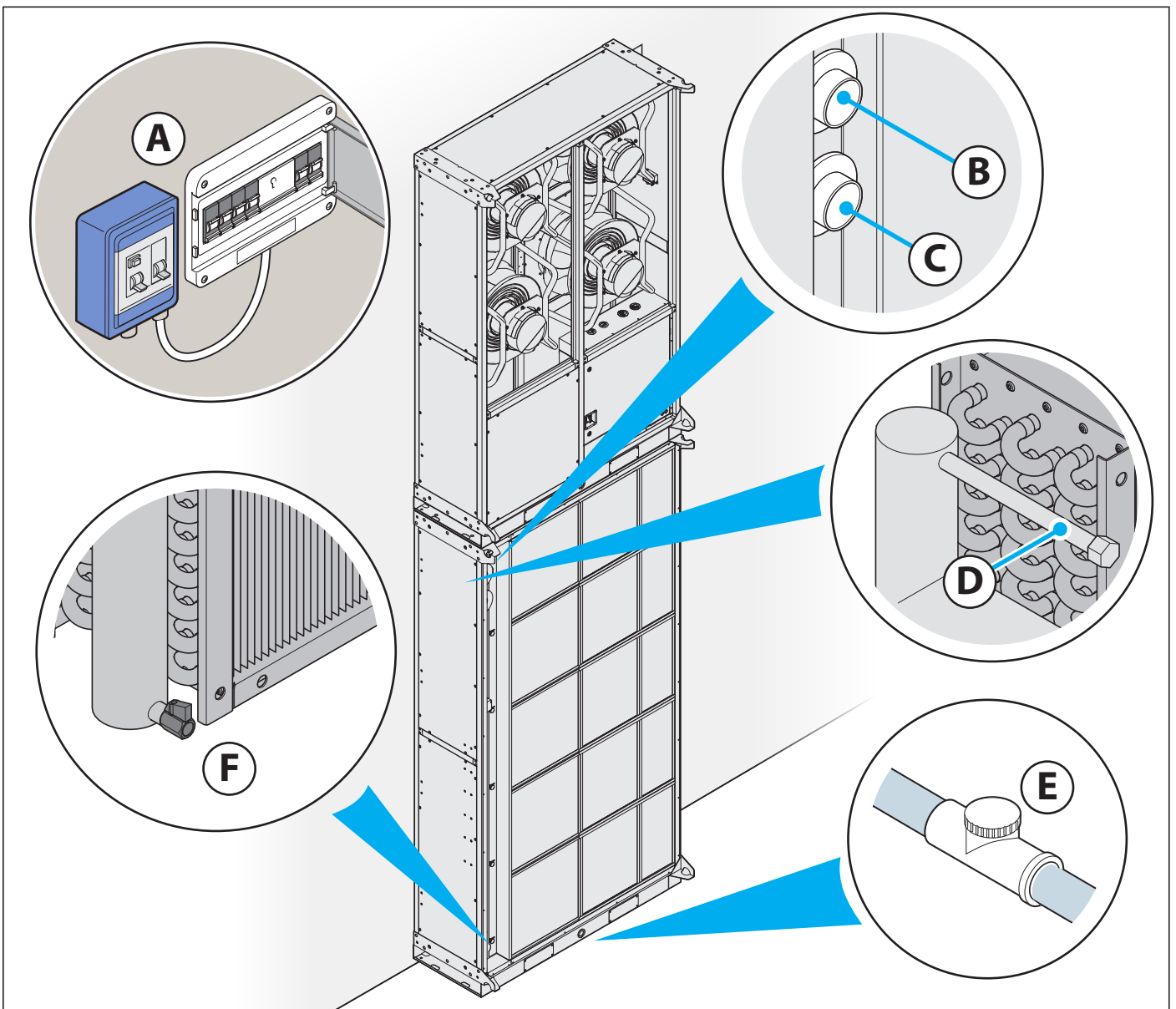

The distance between the inlet and outlet pipes, their respective diameters, as well as the position of the air vent and drain, may vary depending on the coil's construction type and the specific project requirements. These parameters are not standardized and can be influenced by factors such as the number of rows, circuit configuration, type of fluid used, operating conditions, and installation constraints. Therefore, it is essential to refer to the technical documentation and construction drawings provided by the manufacturer for each specific application.

PHASE 2: UNIT ASSEMBLY



9 Ensure that the slings are suitable for lifting and for the weight of the section. During all lifting operations, it is mandatory to use the sling bar to ensure correct load distribution and to keep the lifting slings upright.

9 Transport of the coil section and the fan section

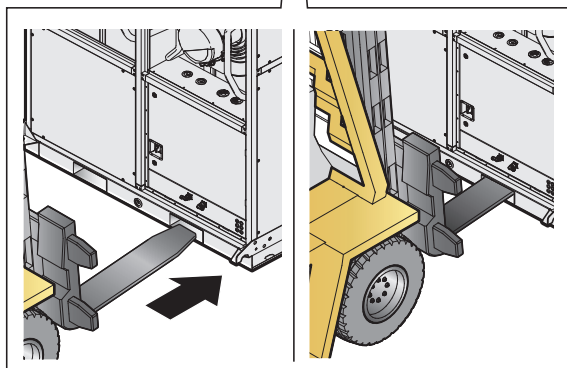
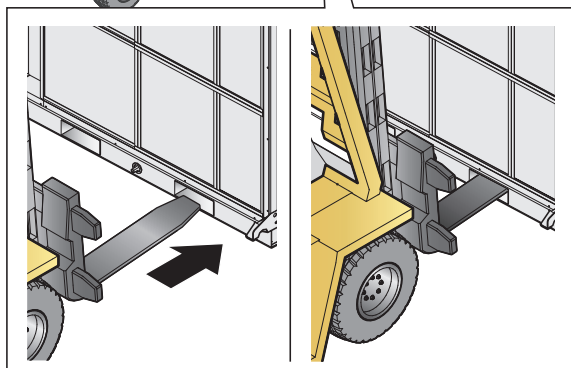
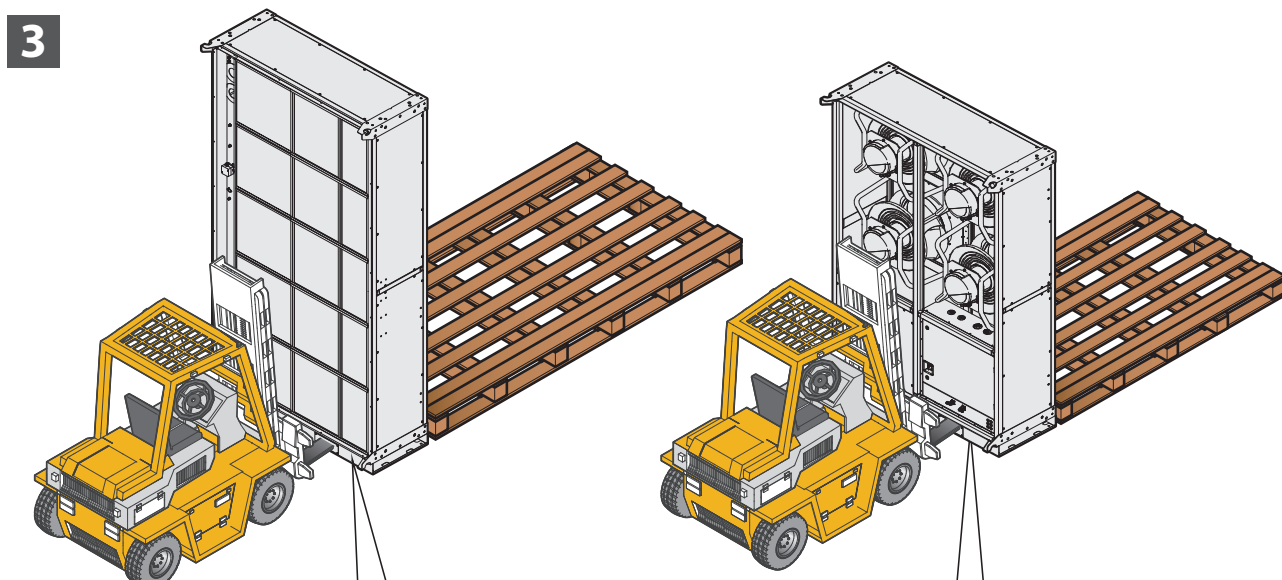
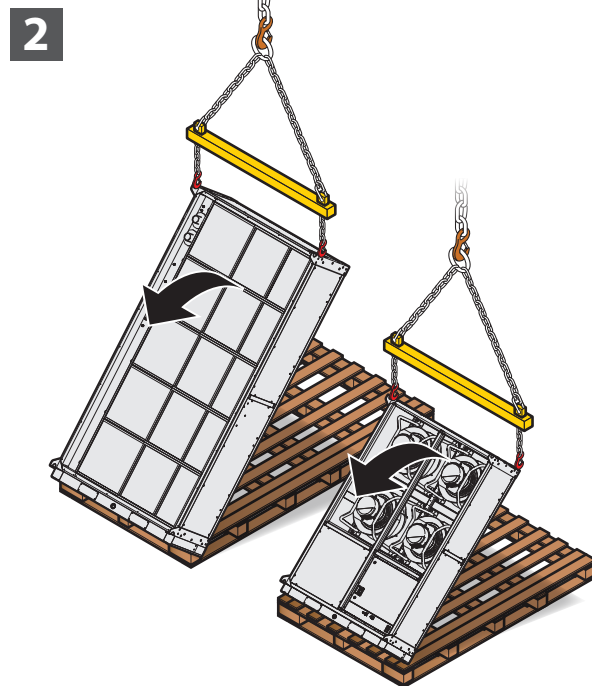
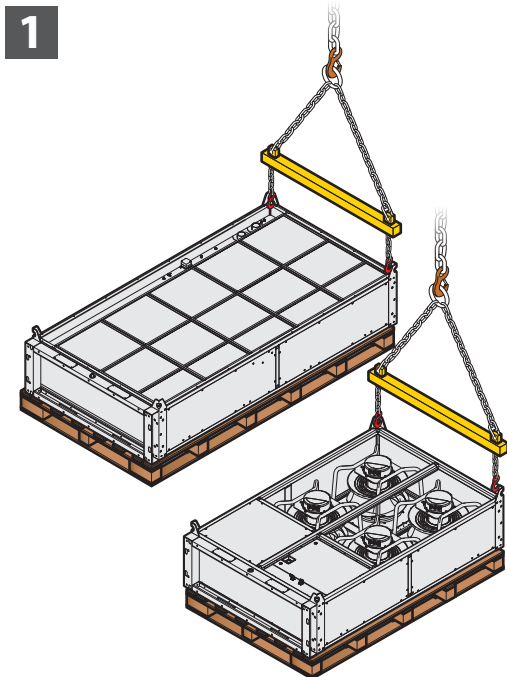

The following is the standard assembly solution. This solution may vary according to project conditions.

10 Fixing of the profiles (standard assembly subject to possible variations)

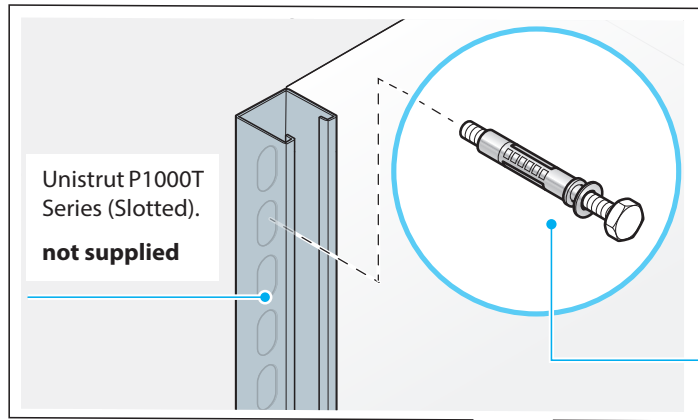

Before installing the machine, it will be necessary to install support profiles (not supplied) to which the two machine sections must be secured.

The profiles must be installed from floor level and their height must be equal or higher than the overall height of the unit.

It is recommended to use certified dowels, of a size and quantity suitable for the expected load, compatible with metric screws, and with a head fully compatible with the holes in the profile.

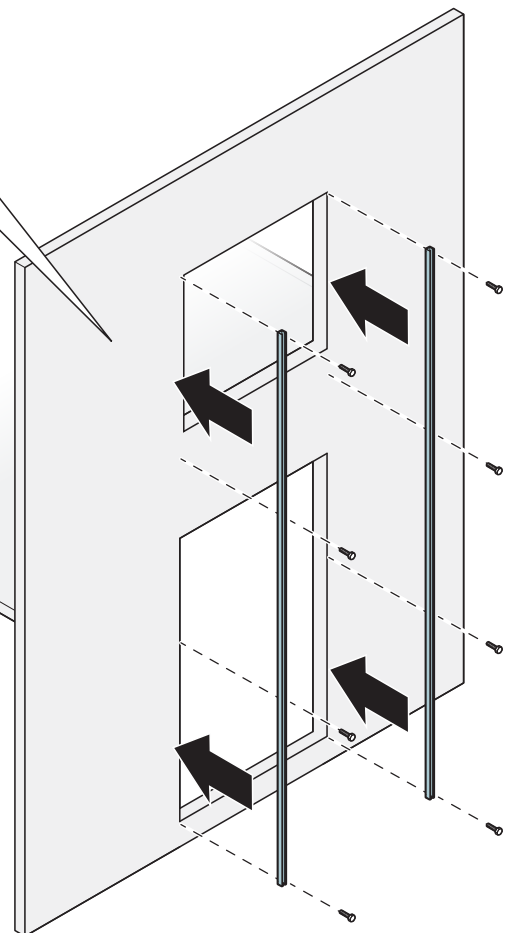
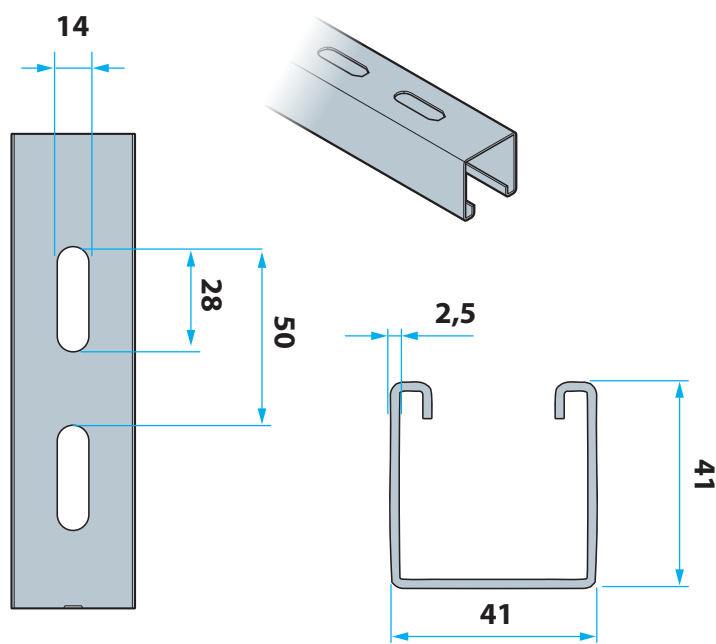
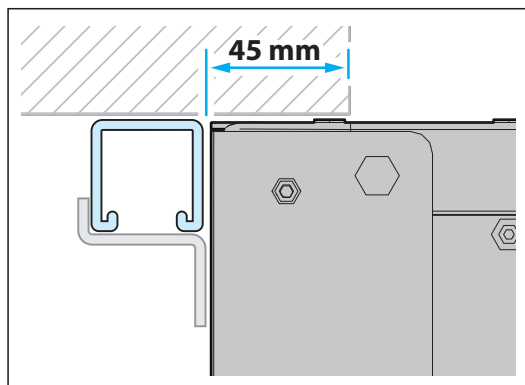

11 Unscrew the ring nut attached to the connector **1 2**. Insert the connector into the dedicated hole in the fan plate **3**. Screw the ring nut back on, securing the connector to the fan plate **4 5**

11 Probe connector installation

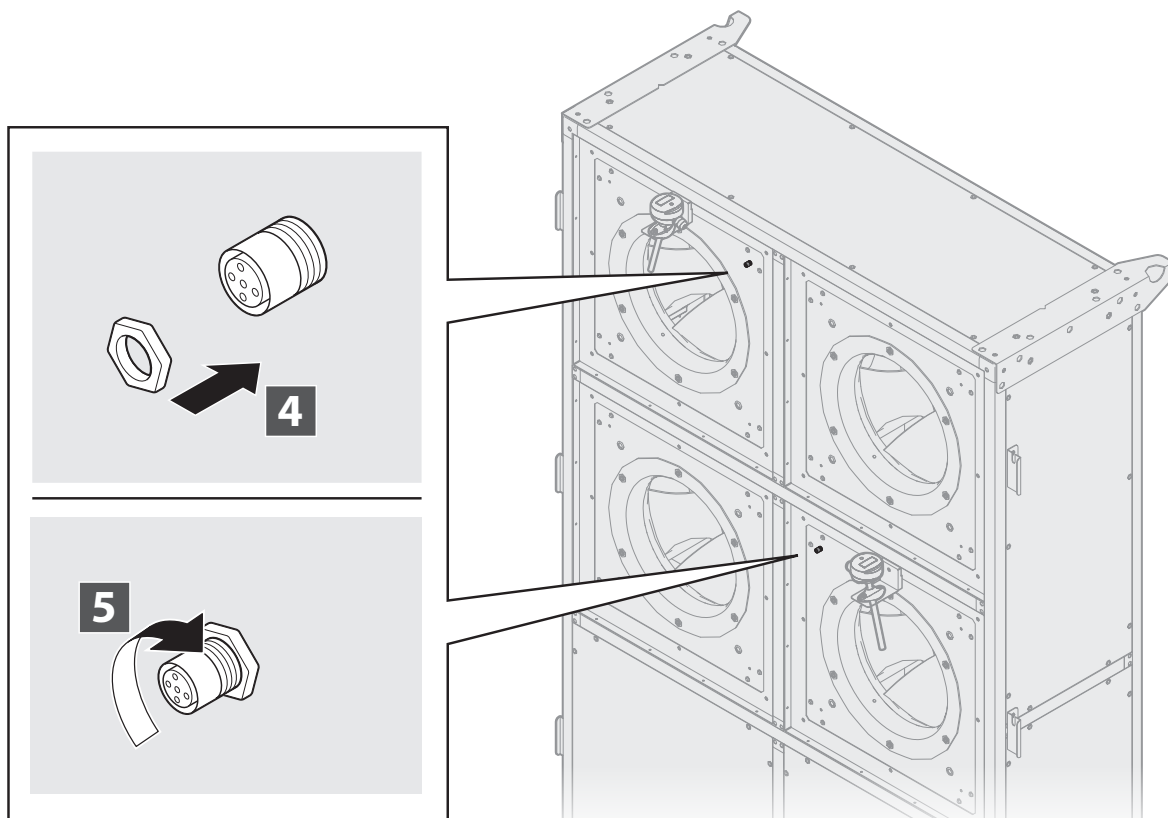
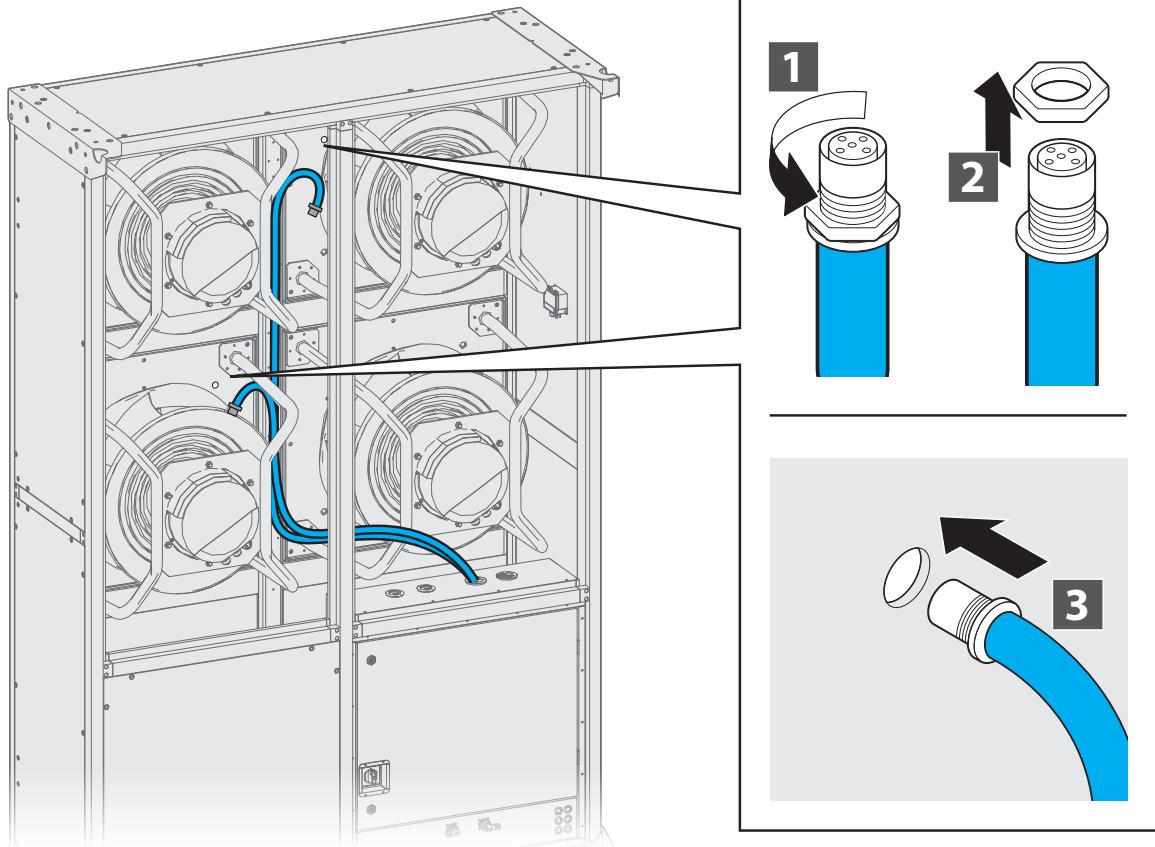

12 Before securing the sections to the wall, apply the seals provided to the surface of the profiles, making sure to cover the entire perimeter of the sections at the recesses in the wall.

12 Application of seals

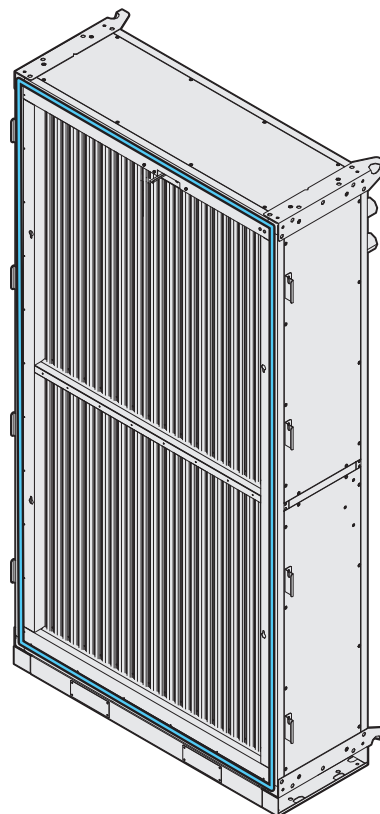
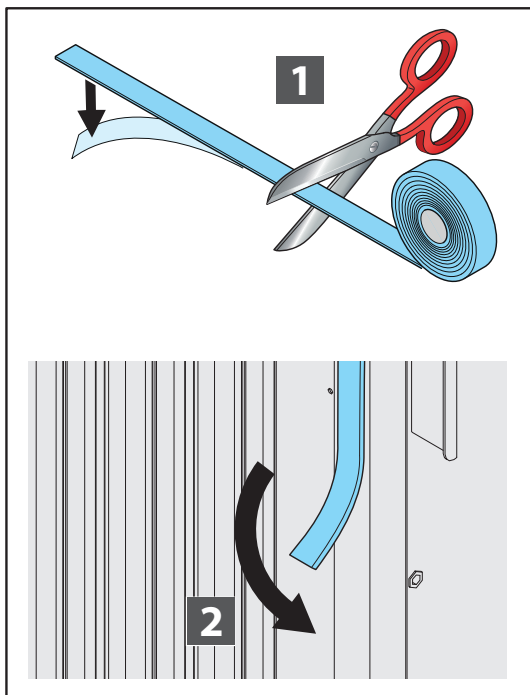
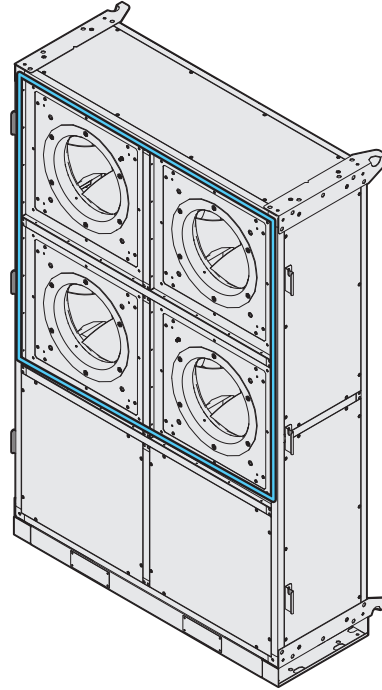
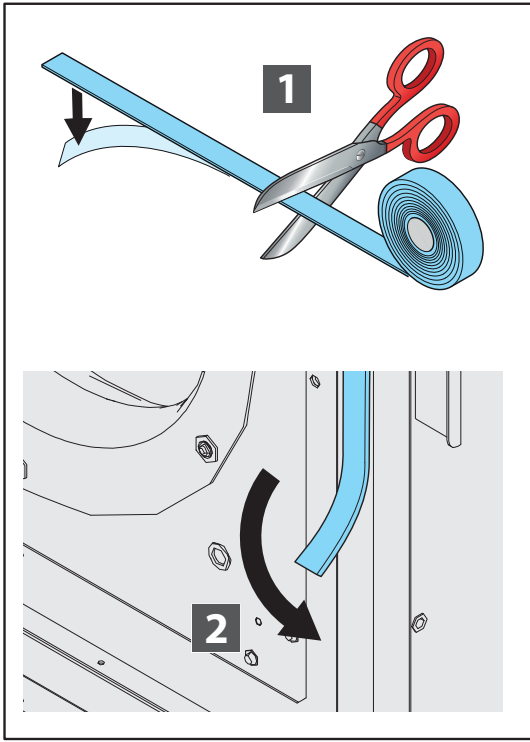

13 Fit the panel fixing brackets using the appropriate screws, split lock washers and washers (supplied)

13 Fixing the brackets

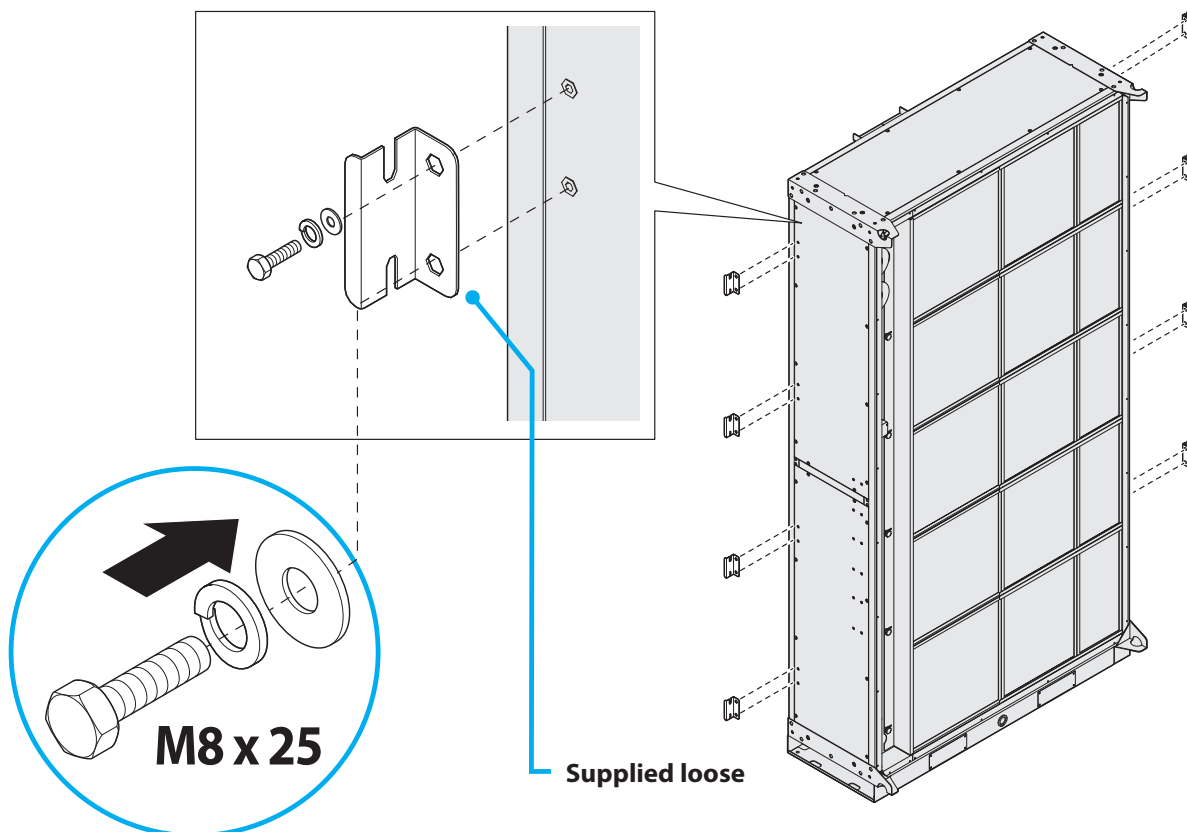
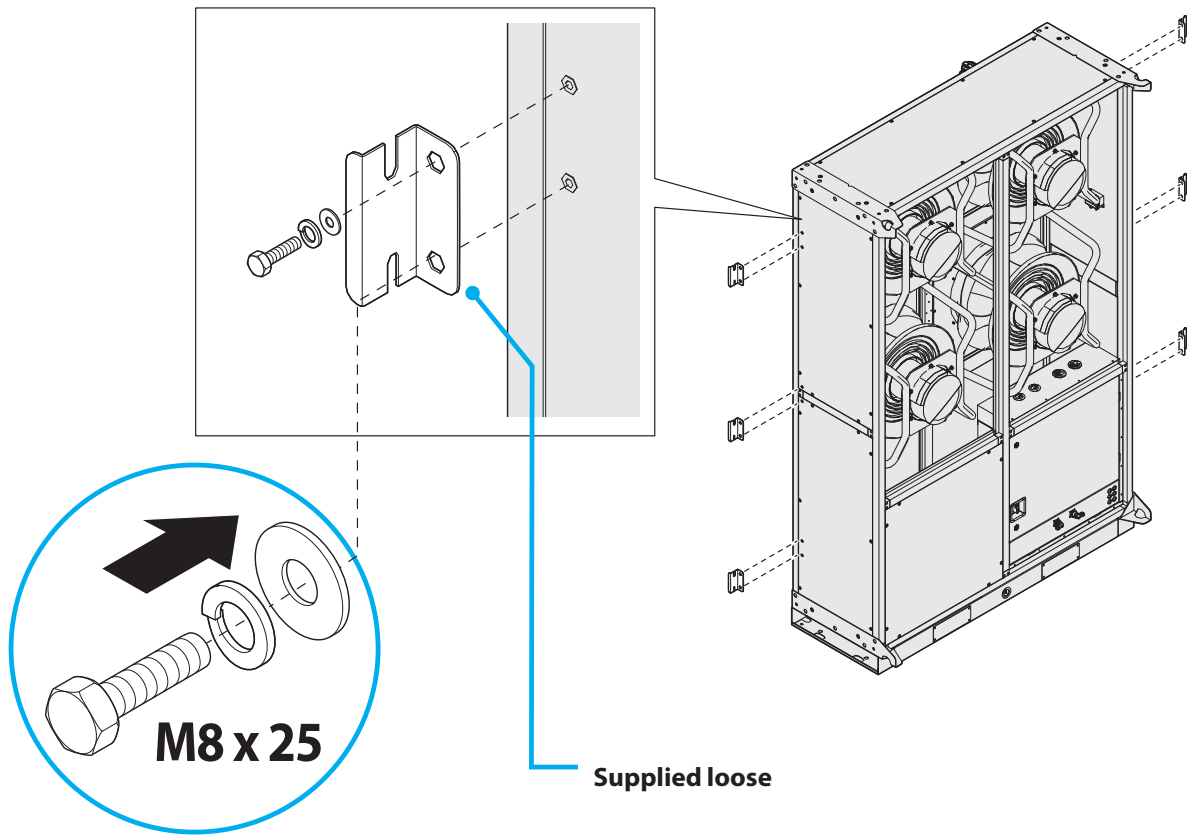

14 Fixing the coil section

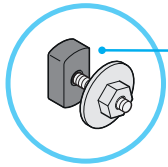

Not provided

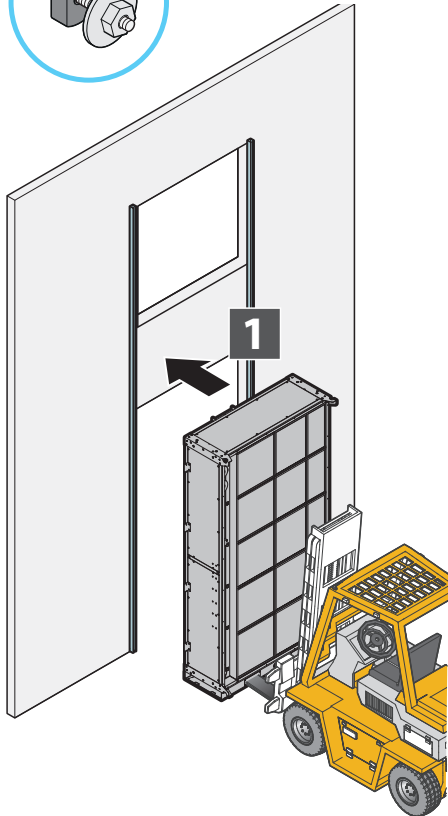

Position the coil section so that the fastening brackets match the Unistrut P1000T Series (Slotted) profile, then fasten them to the profile using the appropriate threaded blocks (not supplied).

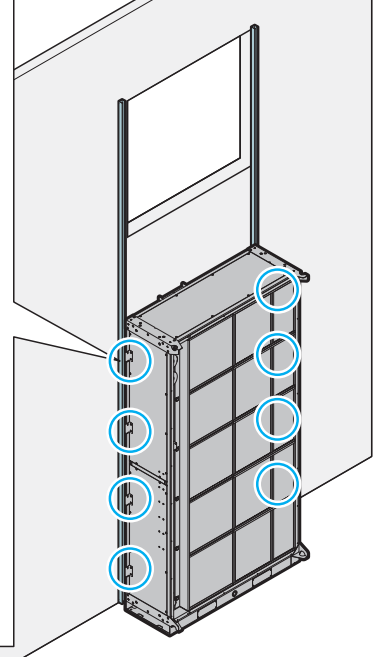

15 Fixing the fan section

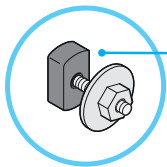

Not provided

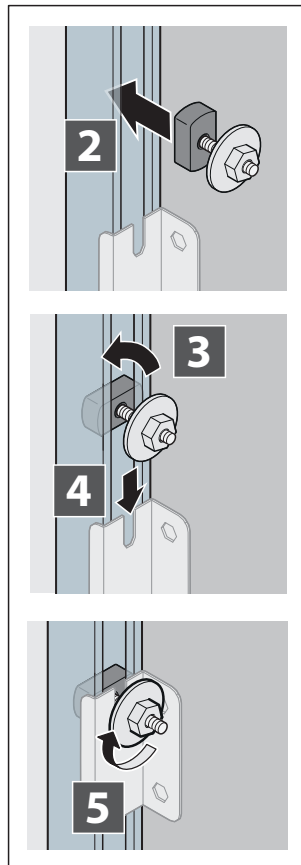
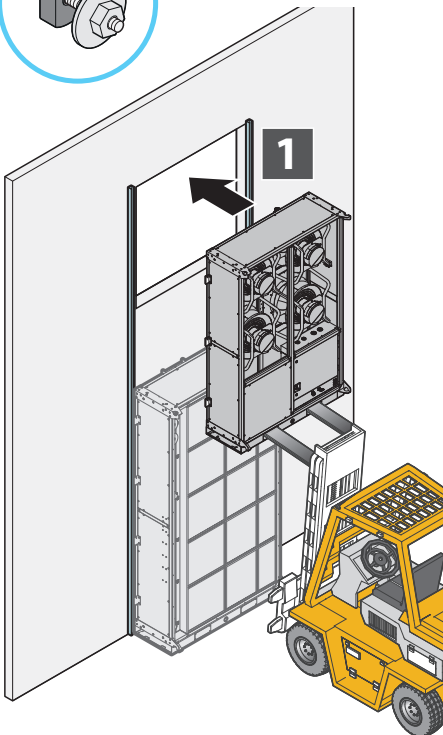

Attach the fan section following the same procedure as for the coil section.

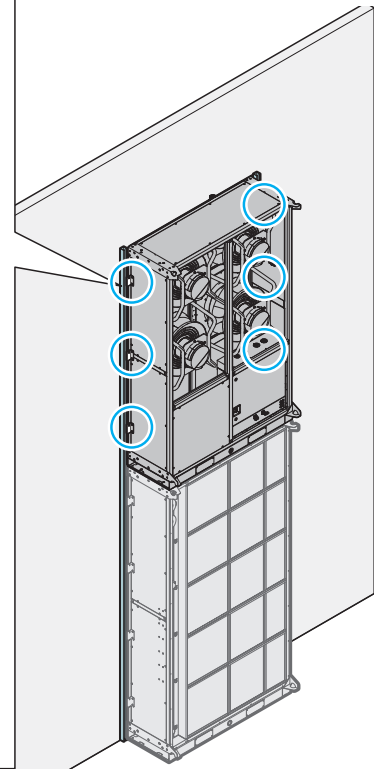

16 After stacking the sections, remove screws, washers and split lock washers from both sides of the coil section at the points indicated in the picture **1** **2**. Store all components carefully. Insert the fixing plate between the two sections **3**. Fit the fold of the fixing plate so that it catches with the fan section bracket and align the holes in the coil section bracket with the holes in the fixing plate **4**. Replace the previously removed screws, split lock washers and washers **5** **6**.

16 Union of fan and coil sections

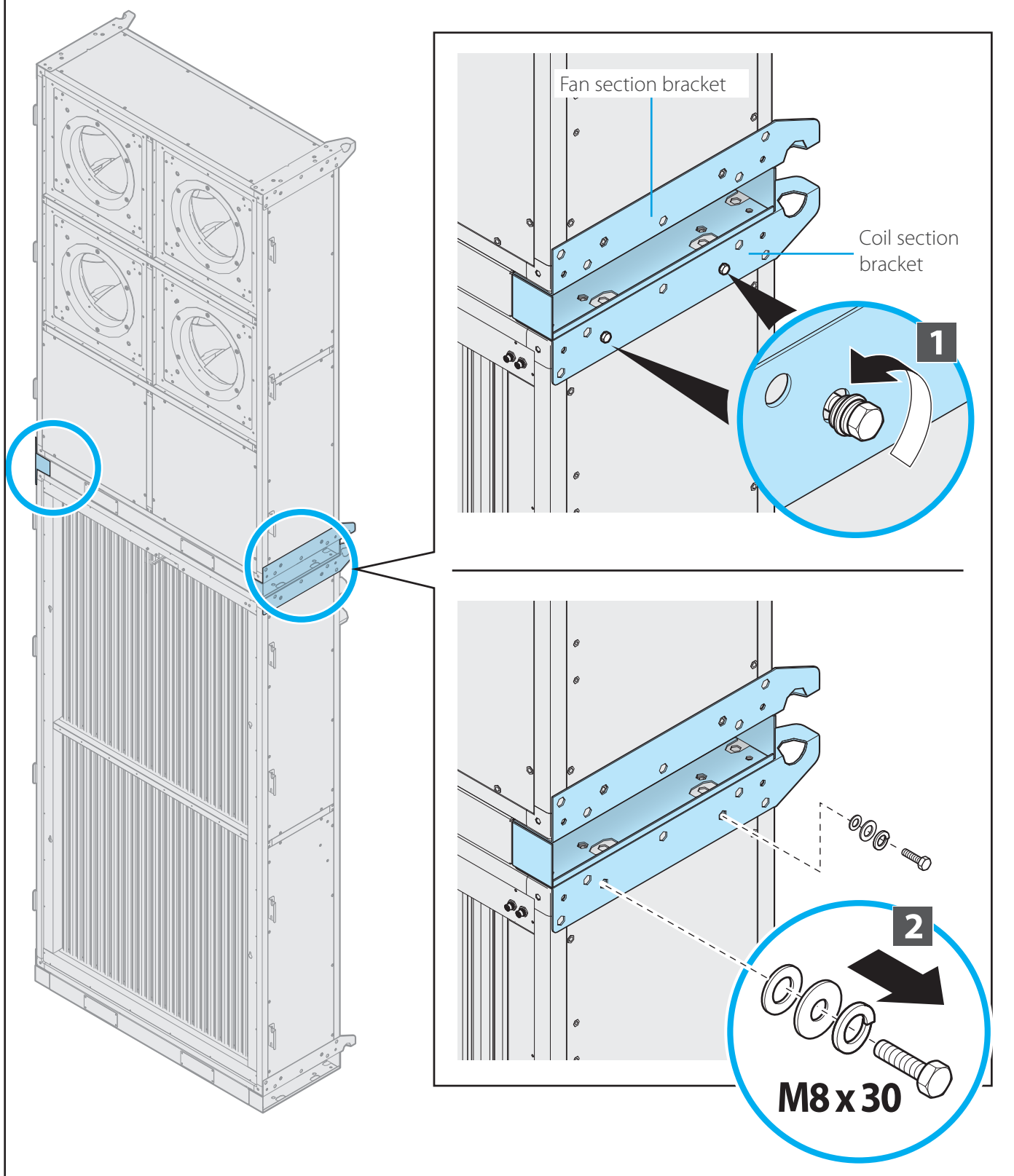

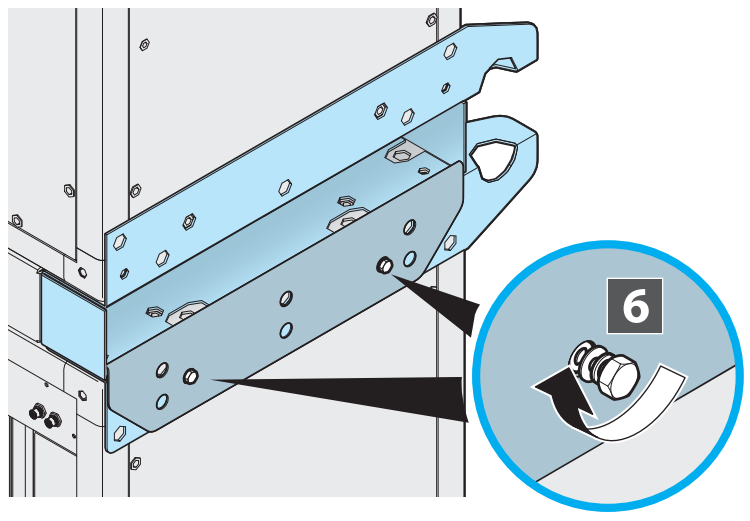
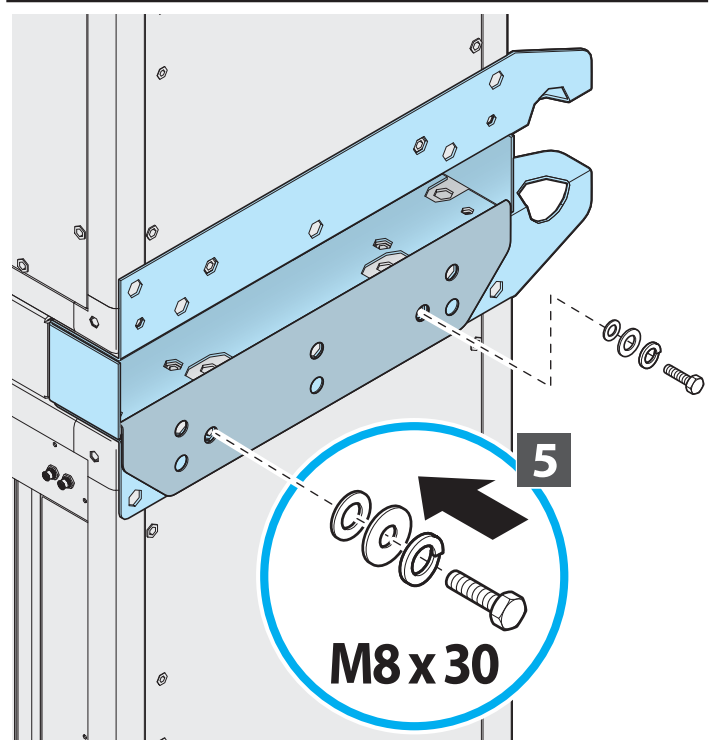
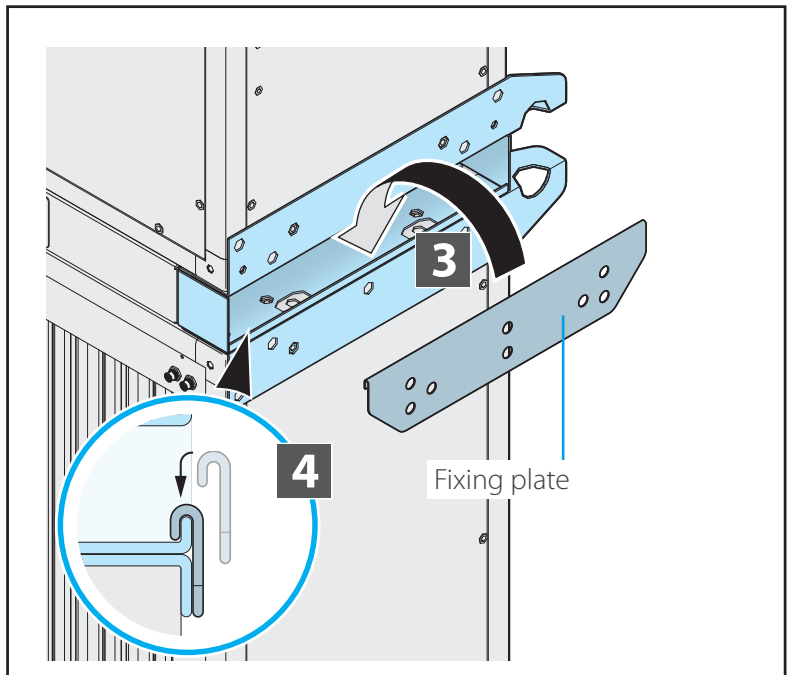
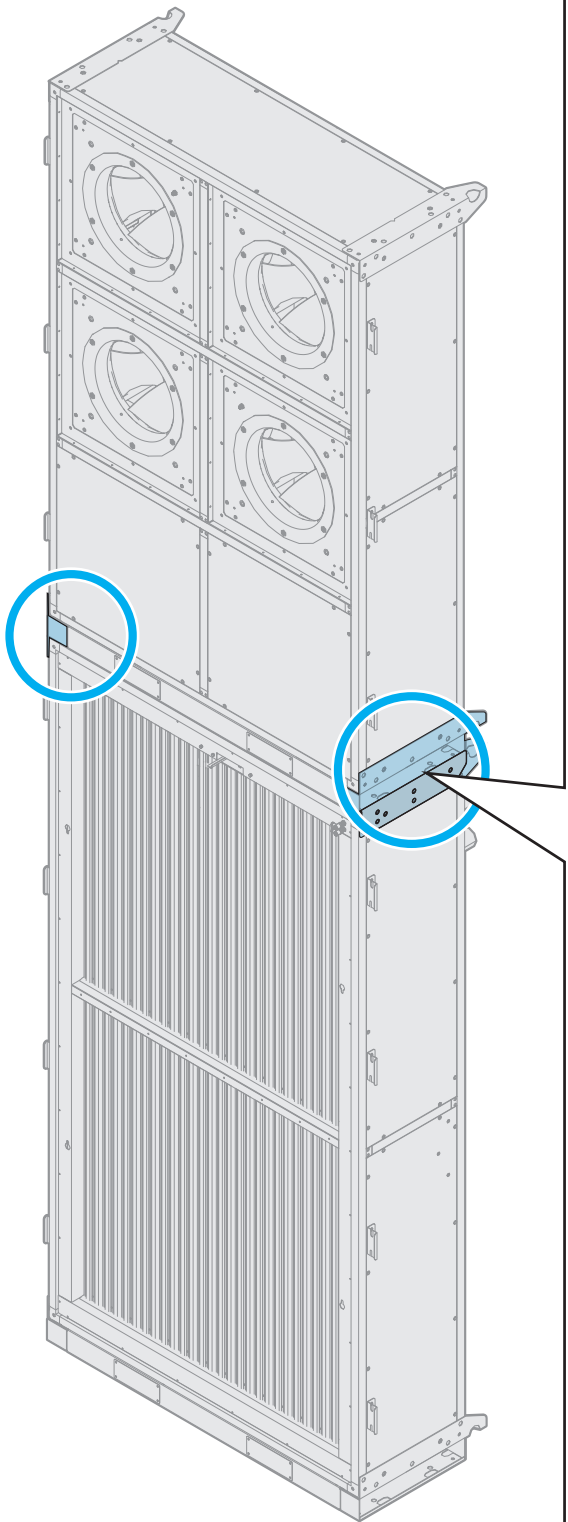

17 Mounting brackets

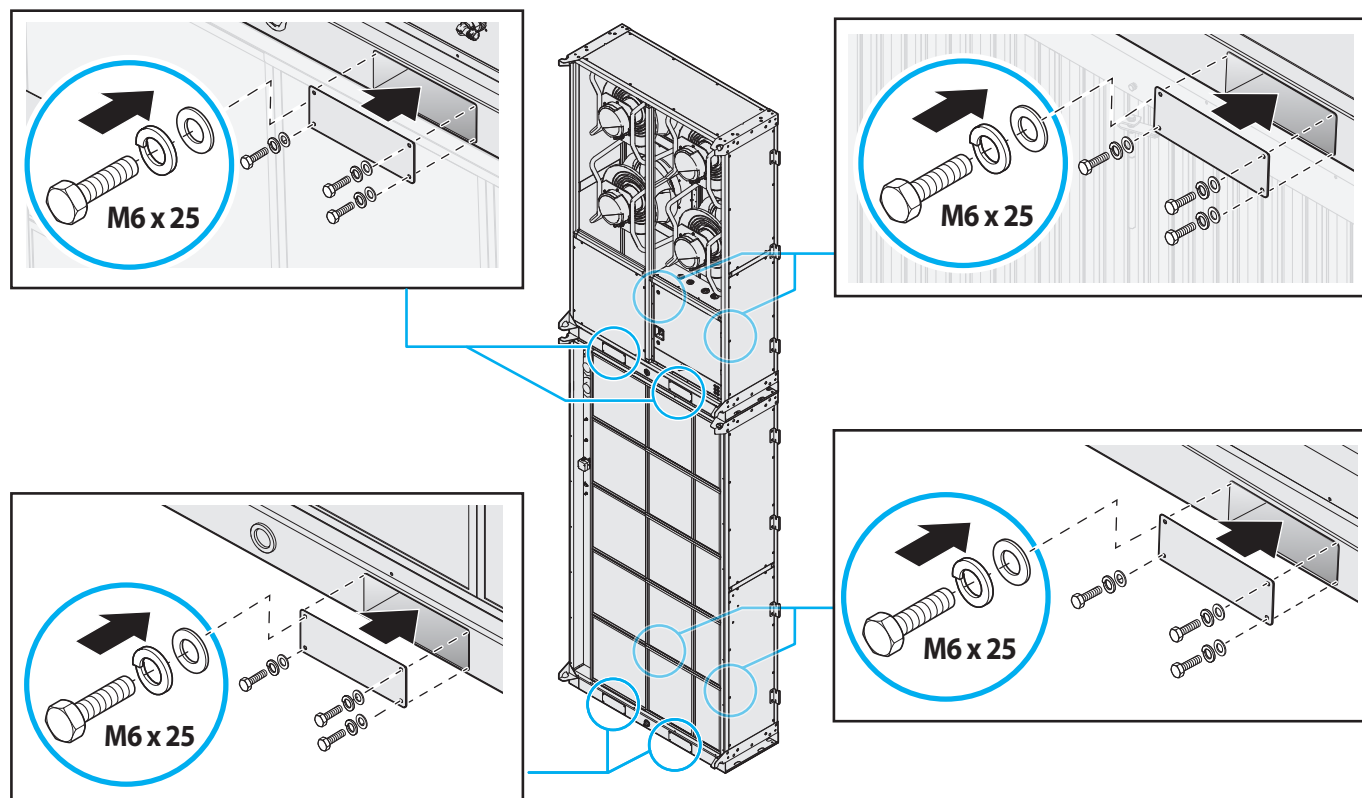

18 Fixing the actuator

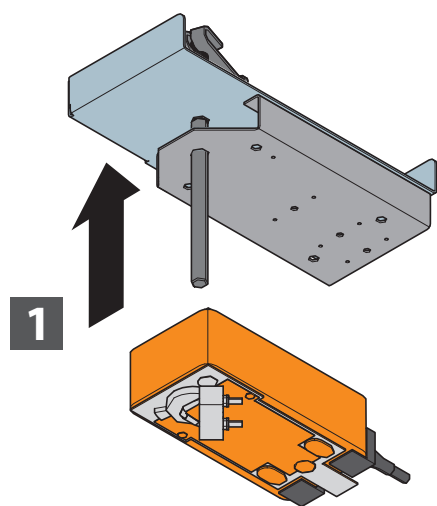

Insert the actuator into the pin and finish mounting on the bracket using the appropriate fastening components. Read the dedicated manual inside the actuator package.

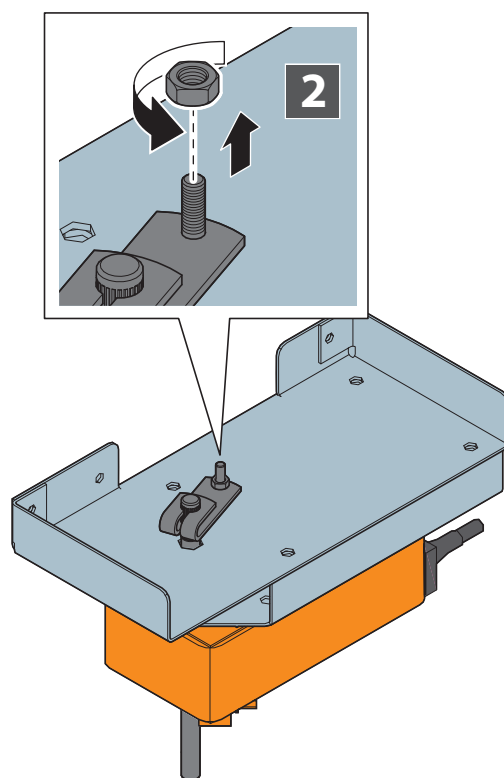

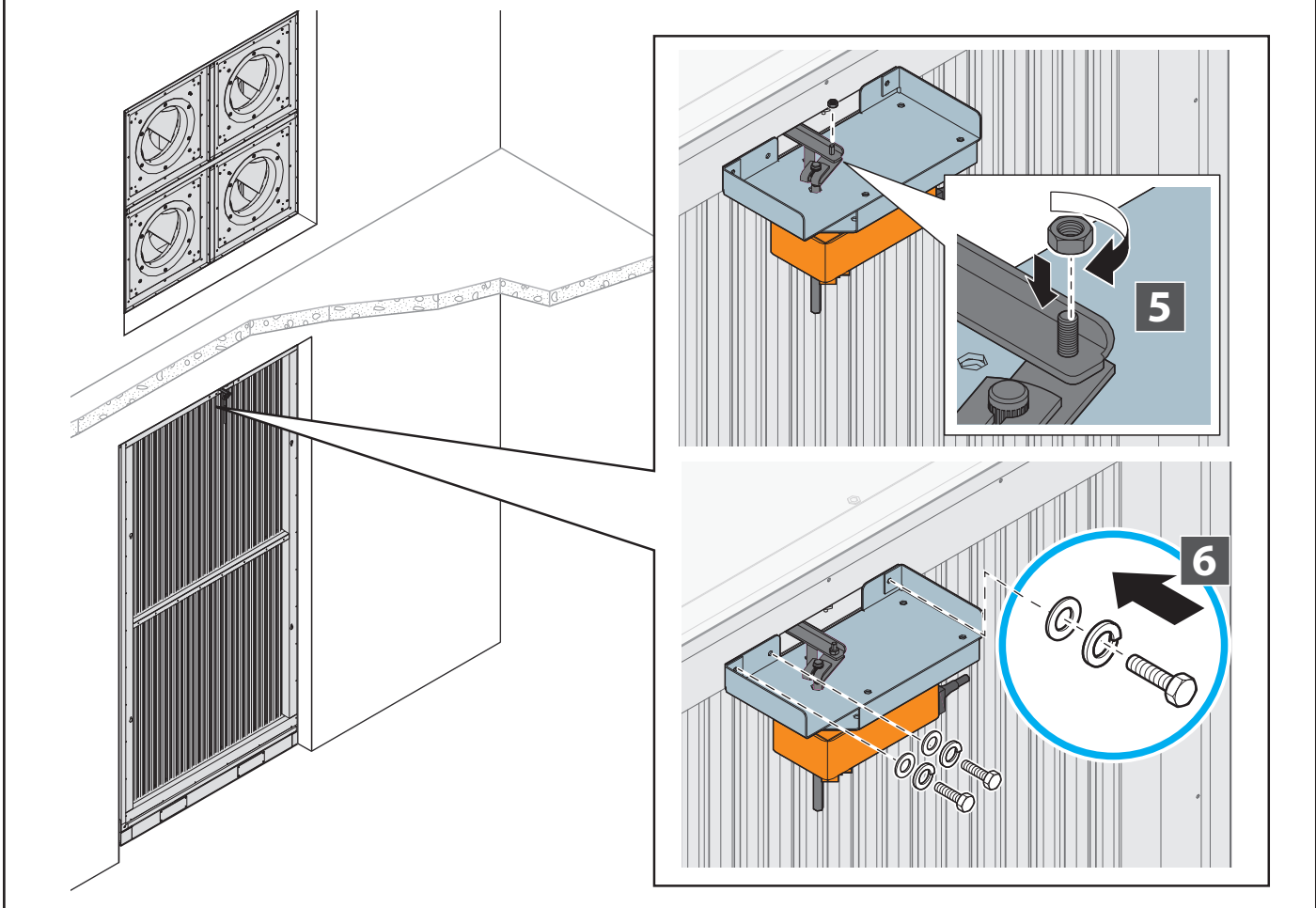
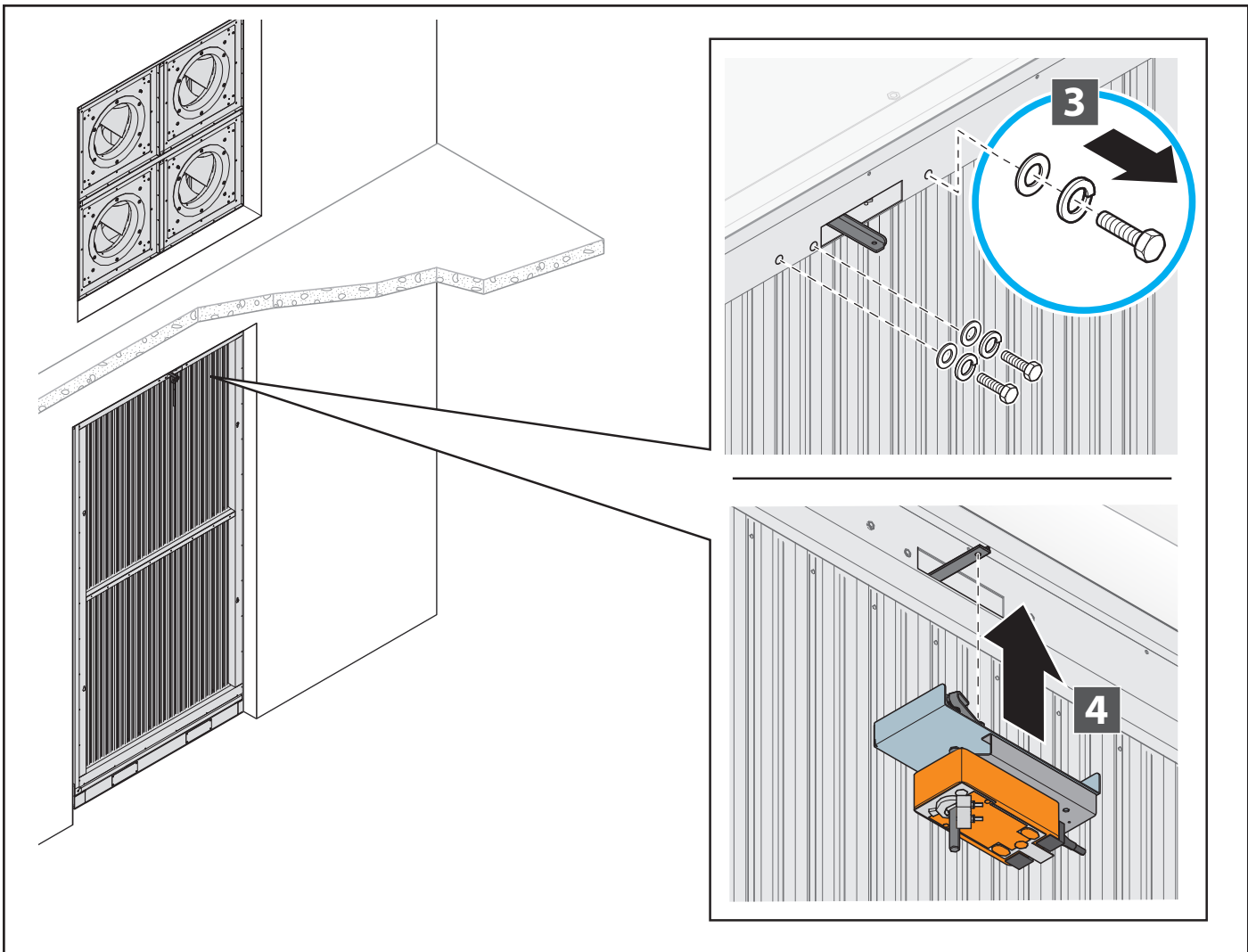

HUMIDITY AND TEMPERATURE PROBE INSTALLATION

19 Identify the fan fastening screw to use for the assembly. Remove the nut, split lock washer and flat washer on the screw **1** **2**. Couple the "L" bracket to the screw, fitting the hole of the bracket onto the screw **3**. Reinsert the flat washer, the split lock washer and finally the nut **4**. Tighten the nut to ensure secure fastening and avoid deformation of the bracket **5**.

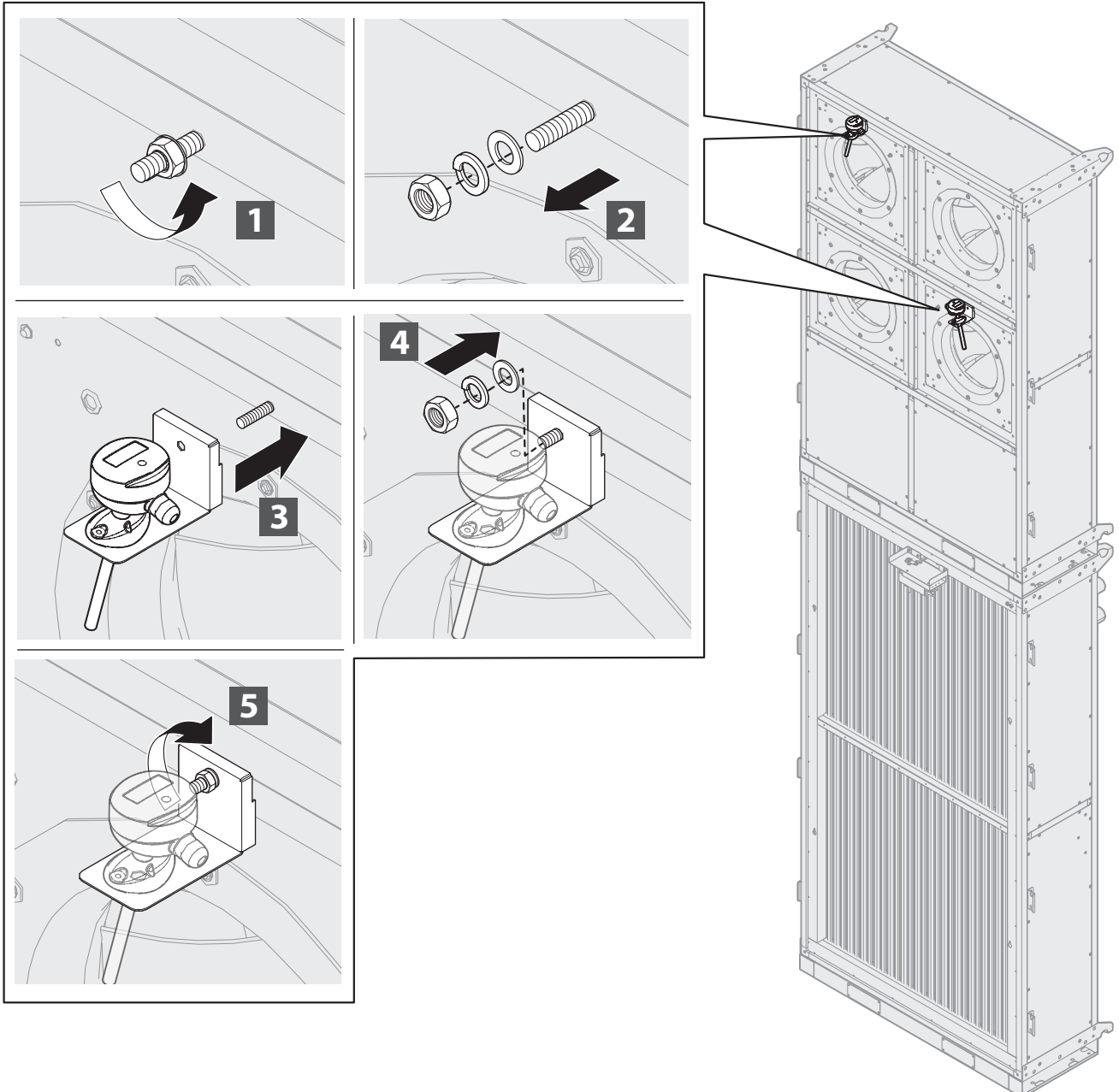

19 Humidity and temperature probe installation

PHASE 3: ELECTRICAL CONNECTIONS

SAFETY WARNINGS



For the **power supply** it is necessary to connect the unit to an electrical panel in compliance with current regulations.



The Manufacturer is not responsible for connections made in a manner that does not comply with regulations, with the specifications of this manual, and in the event of tampering with any electrical component of the unit.

Before connecting the electrical panel, make sure that:

- the voltage and frequency of the network correspond to the parameters of the unit.
- the electrical system being connected has sufficient capacity to supply the nominal electric power of the unit to be installed and meets current regulations.
- **A Residual Current Device" (RCD) device is installed.**



The electrical connection must be:

- made by qualified personnel after cutting off the facility's power supply;
- performed in a fixed and permanent manner, without intermediate splices, in compliance with the regulations of the country of installation.
- adequate to the absorption of the unit (see technical specifications).
- provided with a functioning grounded plug. For multiple units it is necessary to connect each unit to the ground connection or combine them all with metal ties.
- preferably situated in a dedicated room, **locked** and protected from the weather. If there is also a key switch, the key must be removed when cutting the power supply and returned to its position only after finishing service operations.
- Install a **suitable circuit breaker system**



During the electrical connection, make sure that **no person**, other than the one who is working on the system, has access to the electrical rooms or switches.



The actual supply voltage of the users must not deviate more than 10% from the expected normal voltage. Higher voltage differences cause damage to users and to the electrical system, malfunctioning of fans, noise level. It is therefore essential to check the alignment of the actual voltage values with the nominal values. The line frequency must be between 0.99 and 1.01 of the nominal value; up to 0.98 and 1.02 for a short time. The voltage unbalance must not exceed a 2% deviation. The voltage must not be interrupted for more than 3 ms in any random cycle and more than 1 s must elapse between two successive interruptions. The voltage dips must not exceed 20% of the RMS voltage of the supply line. More than 1 s must elapse between successive dips.

After connecting, make sure that:

- the ground connection is sufficient (using the appropriate instrument). An incorrect connection, ineffective and lacking the grounding circuit, is contrary to safety regulations and is a source of danger and can damage the components of the unit.
- the motor rotation direction is correct.
- the wiring and motor power draw are correct.

Additional warnings regarding the power connection

- A suitable differential protection must be installed upstream of the machine's power connection points, in order to isolate each of its elements in the event of a malfunction; the choice of the differential protection device must not conflict with the provisions of the law, local regulations, the characteristics of the electrical system of the plant and of the machine itself. The unit is compatible with the TT-TN power supply systems

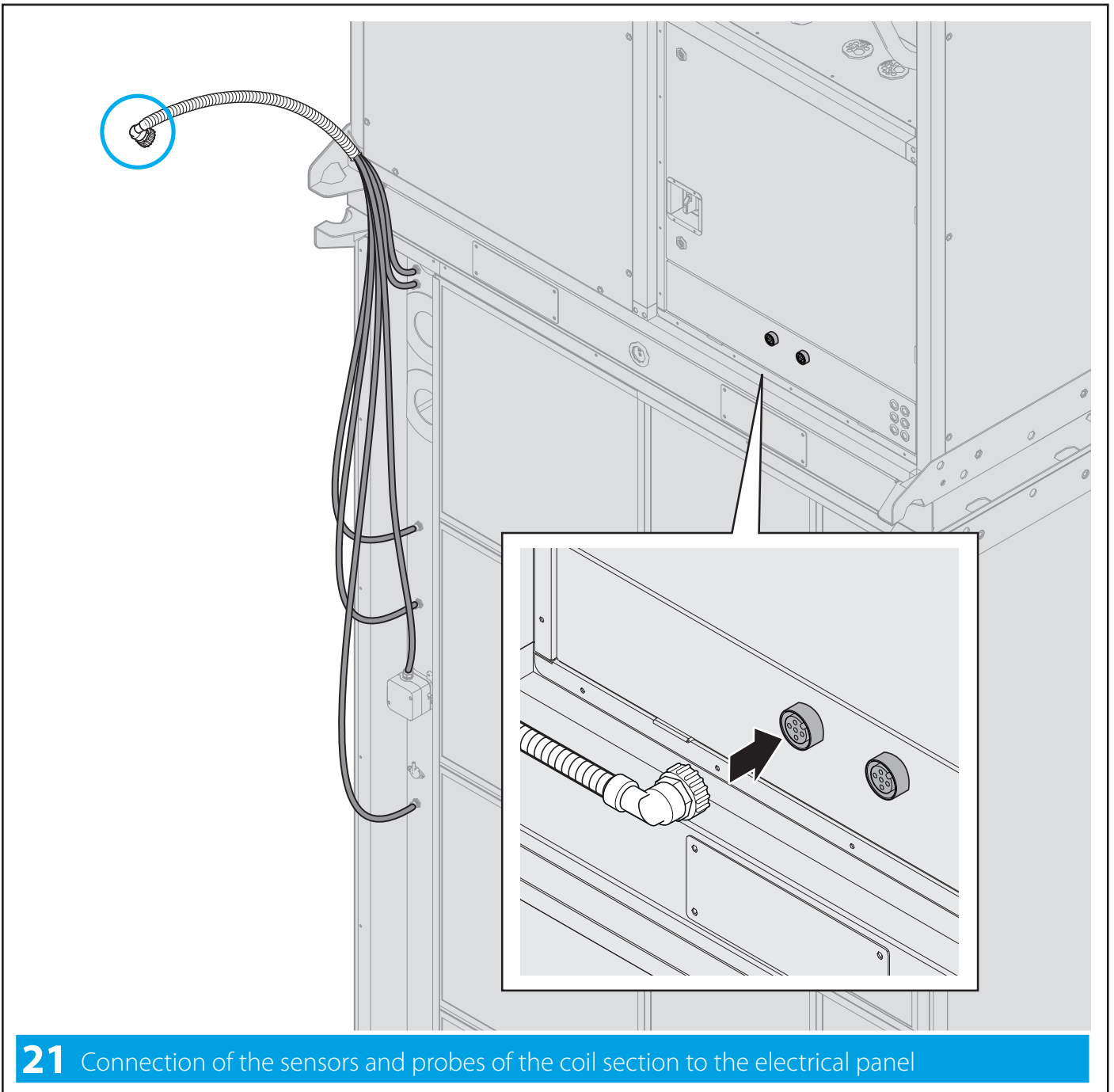
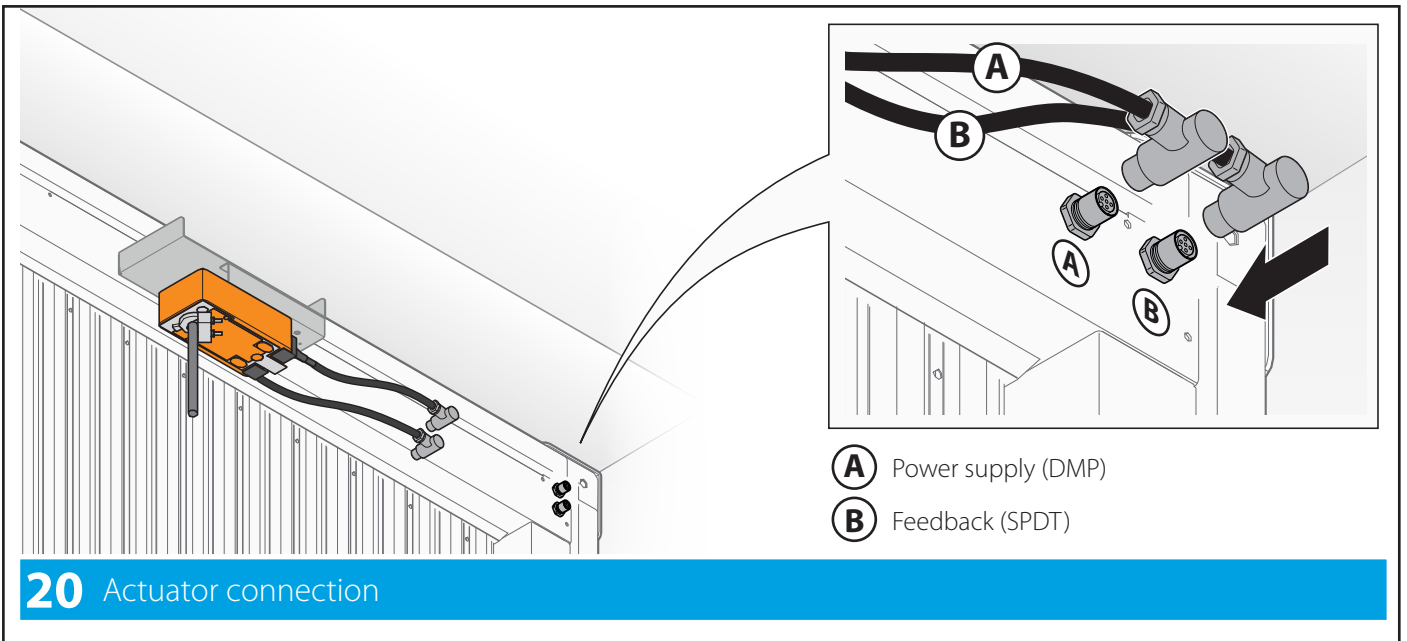

22 Standard unit control box configuration

Depending on requirements, the control box can be mounted with the following configurations. Choose the configuration that allows the control box to be installed without causing obstructions to nearby objects.

Standard right

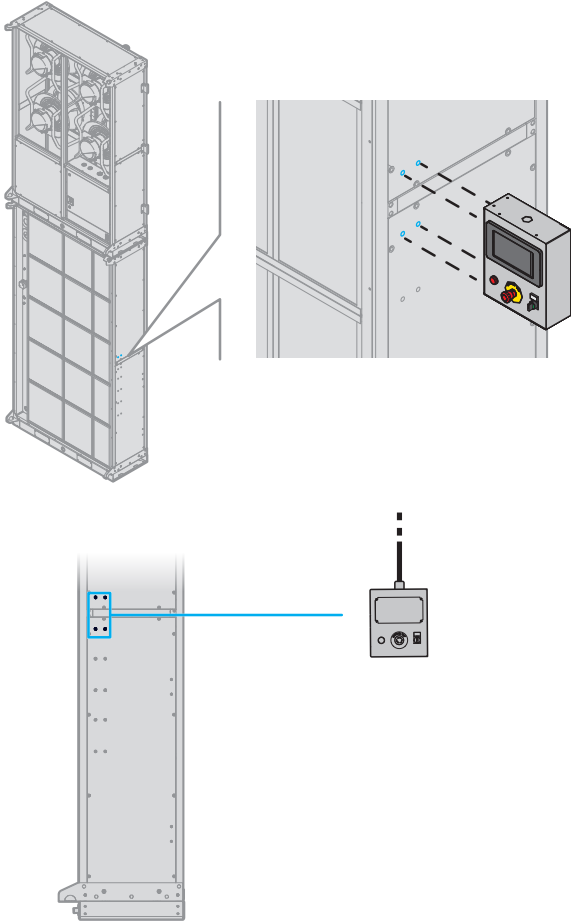

Standard left

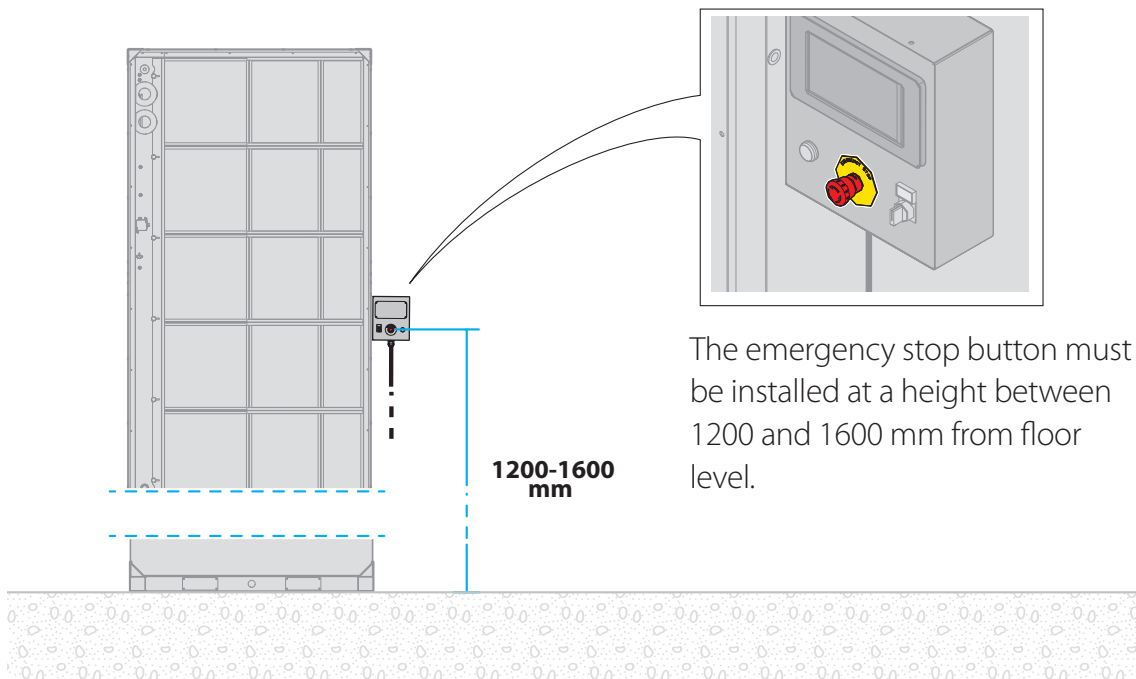
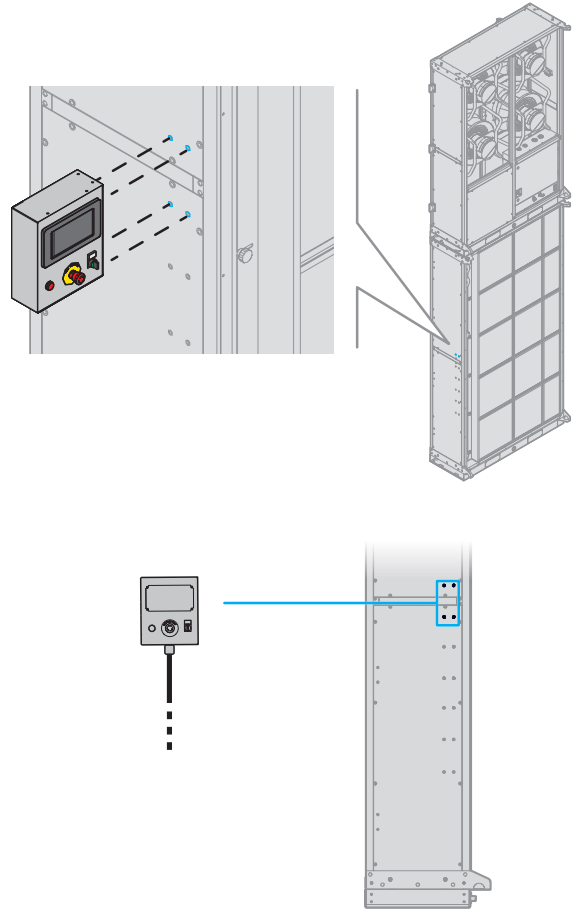

23 Control box assembly (top cable outlet)

Mount the control box shell **1 2 3**. Feed the cable through the outlet hole **4**. Complete the control box connections **5** and close the box **6**. Tighten the cable gland. Fit the screws to close the cover **7**. If mounted on the left side of the machine, rotate the box 180° as shown.

Right side

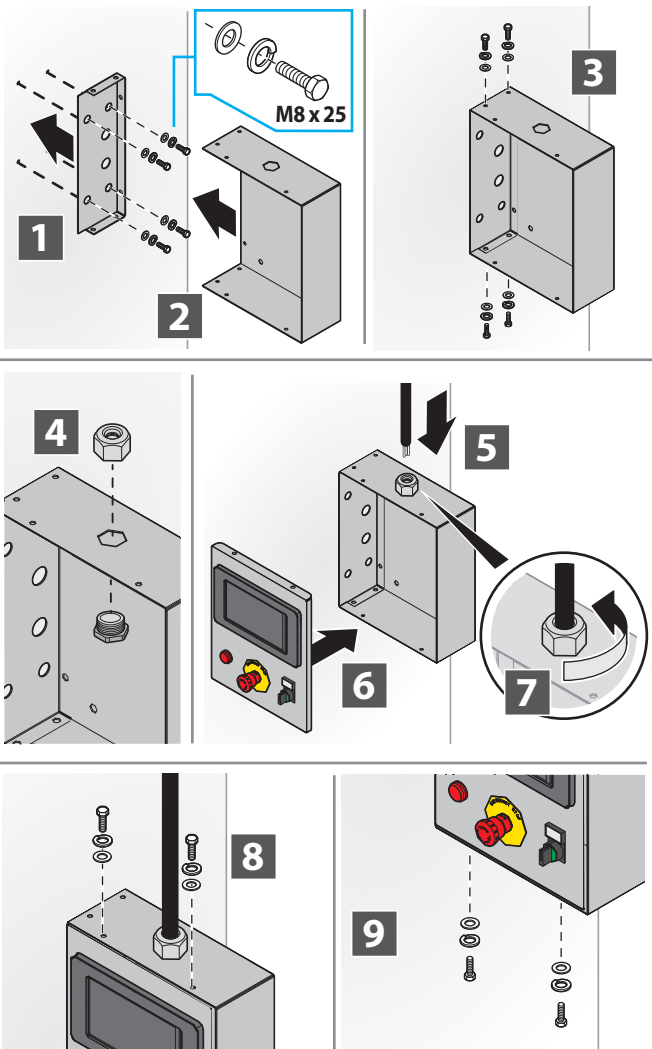

Left side

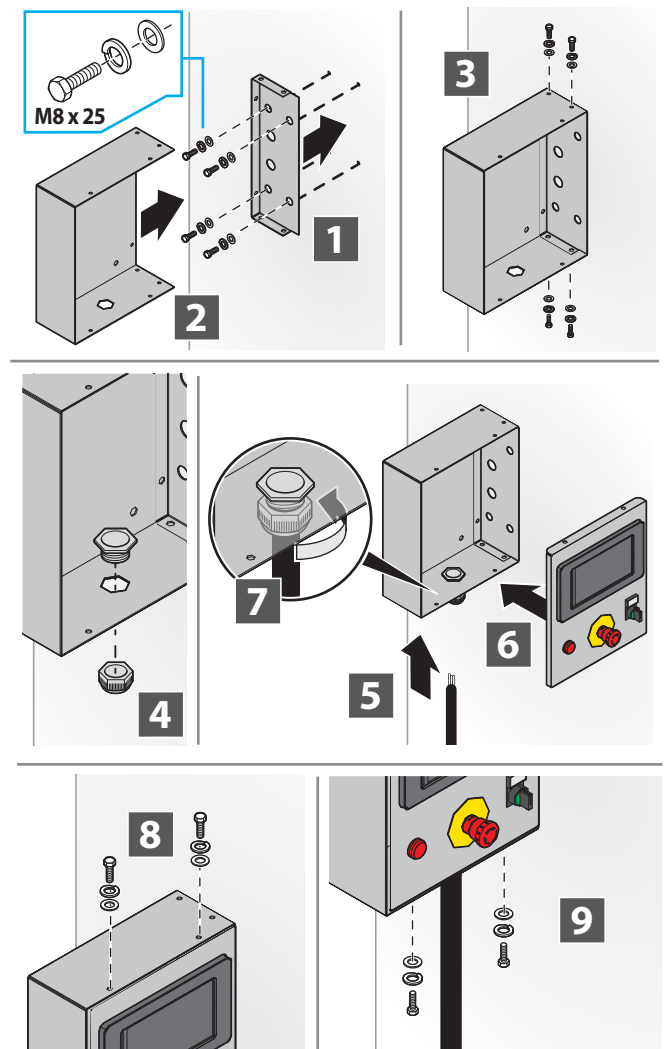

24 Control box connection (Standard Right)

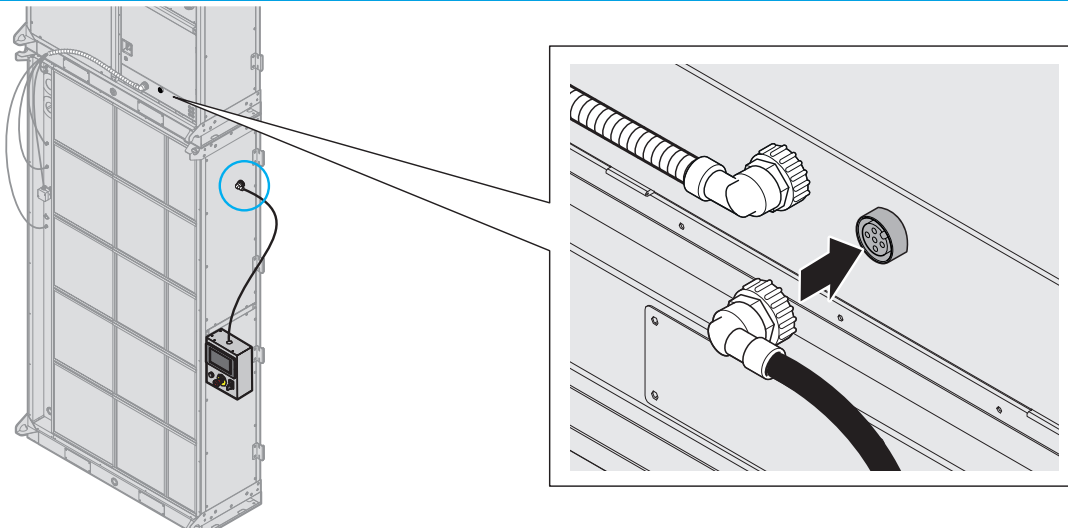

25 Control box connection (Standard Left)

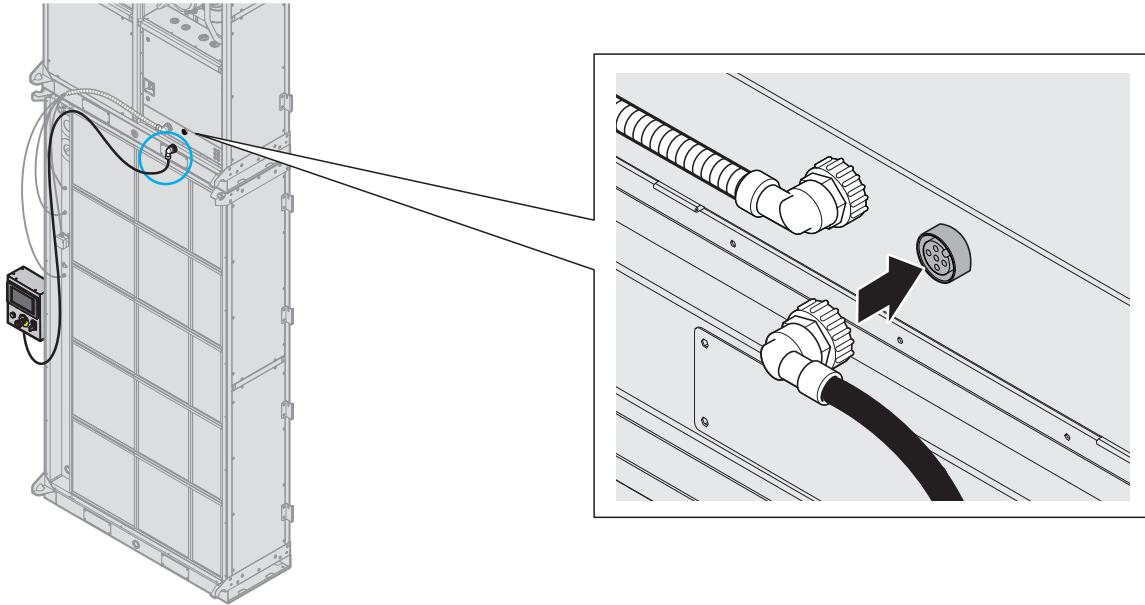

26 Humidity and temperature probe connection

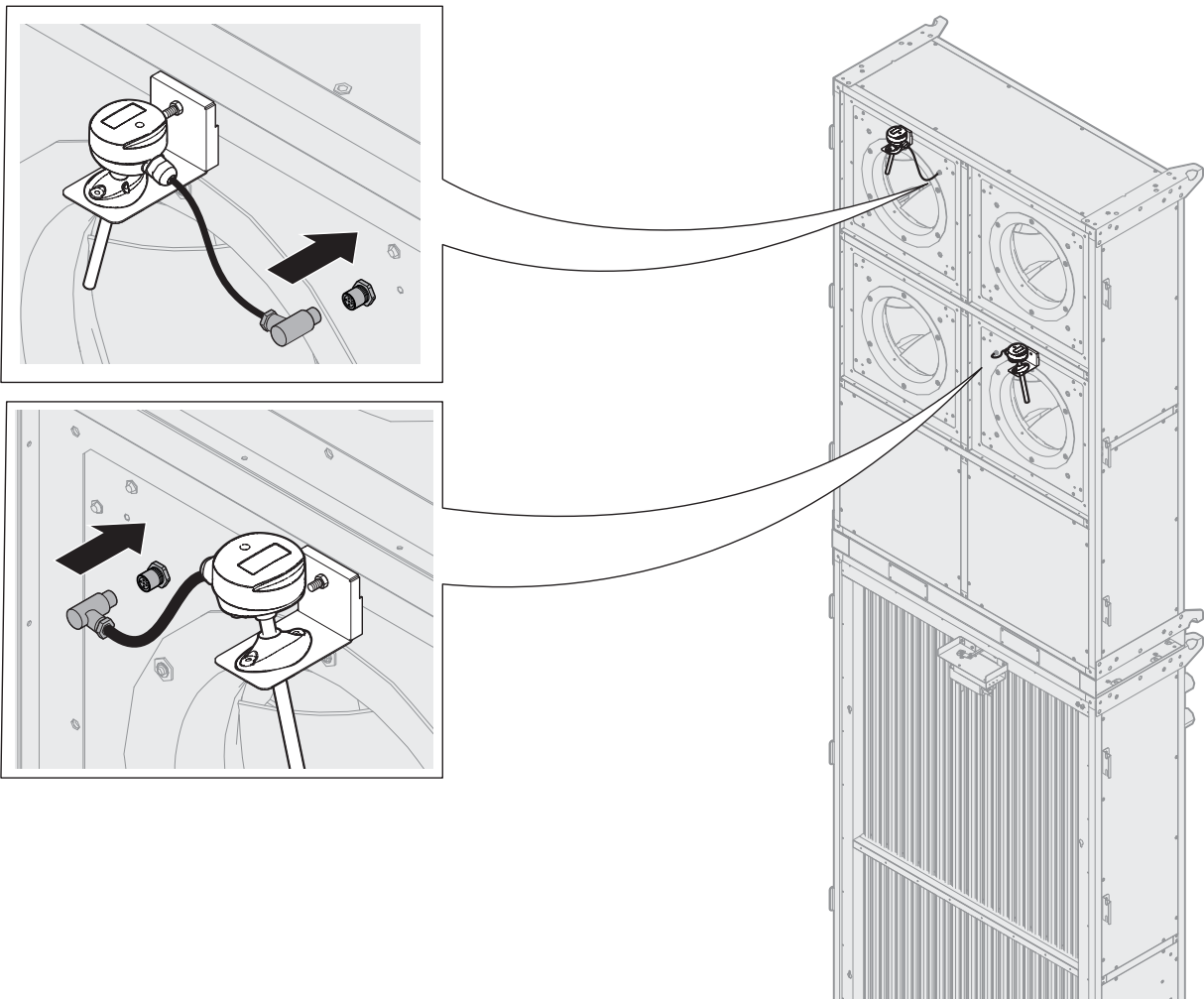

WIRING OF POWER CABLES

- 1** Open the electrical panel.
- 2** Make an incision on the two black grommets as shown in the figure.
- 3** Bring the power cables inside the panel by feeding them through the grommets

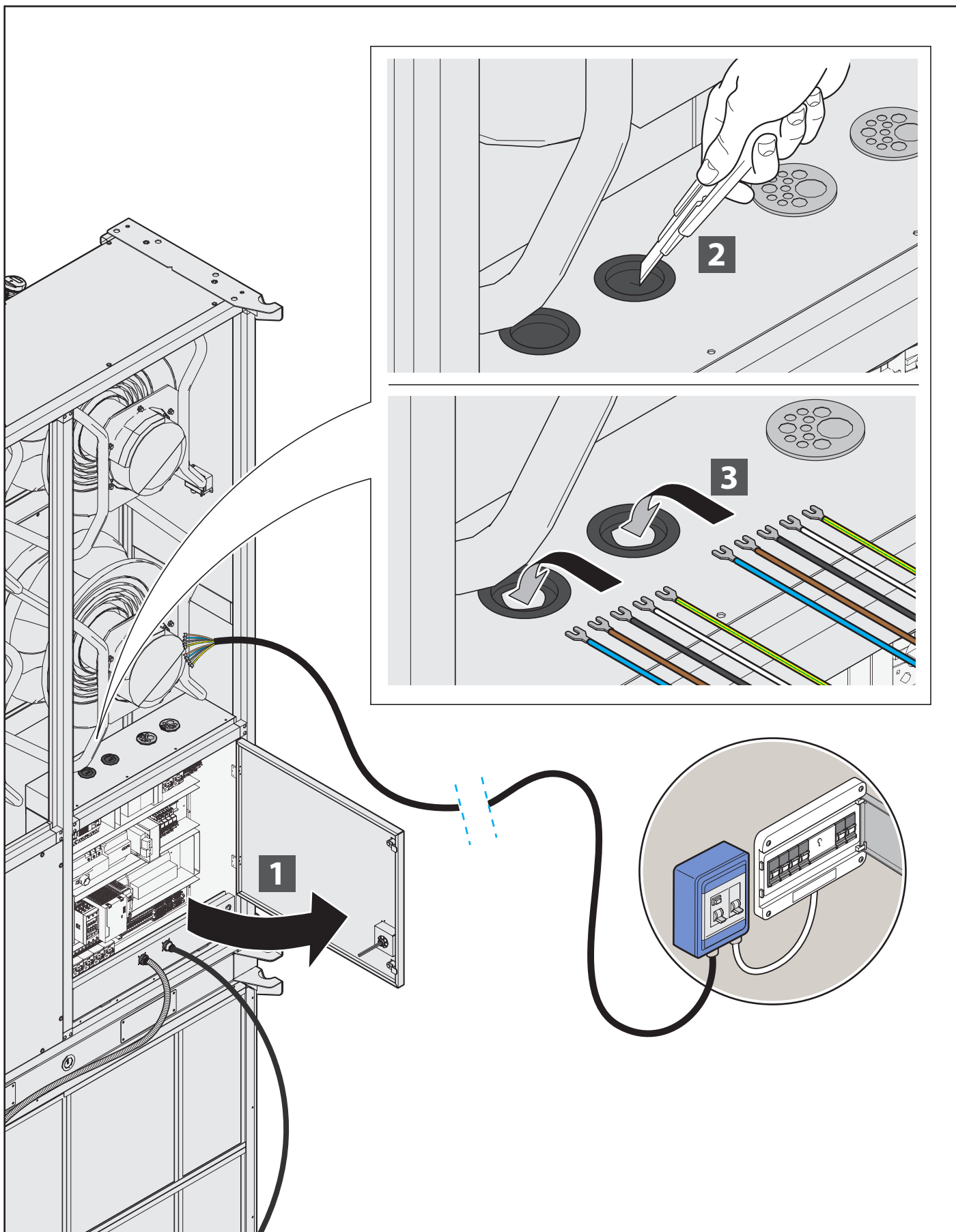

Make sure that the wiring is as shown in the figure **27** . Use cables with fork terminals.

27 Power connection to the panel

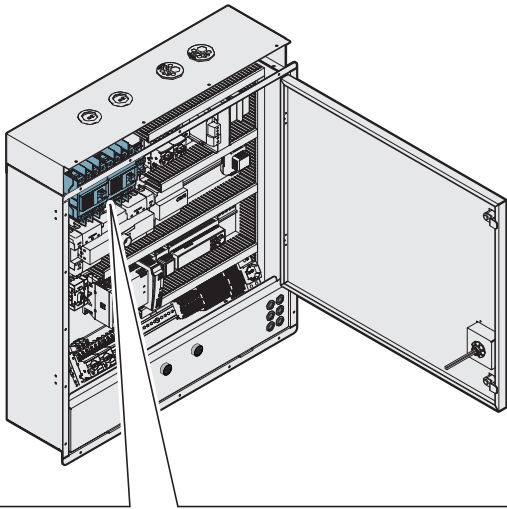

Use cables with
fork terminals.

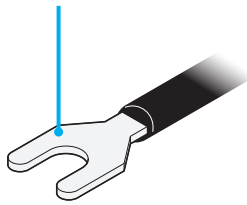

Ferrite 75,
provided

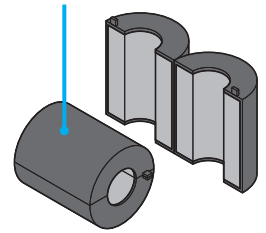

Line 1

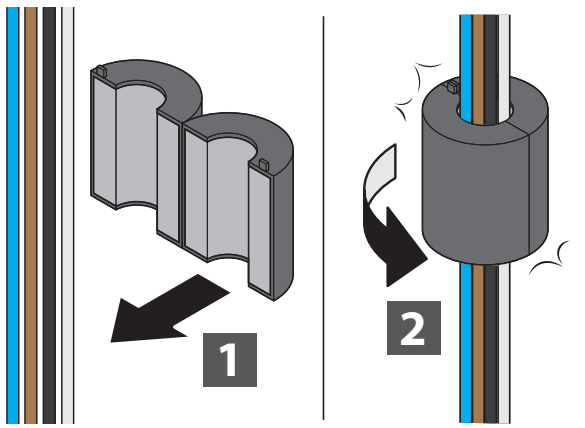

Line 2

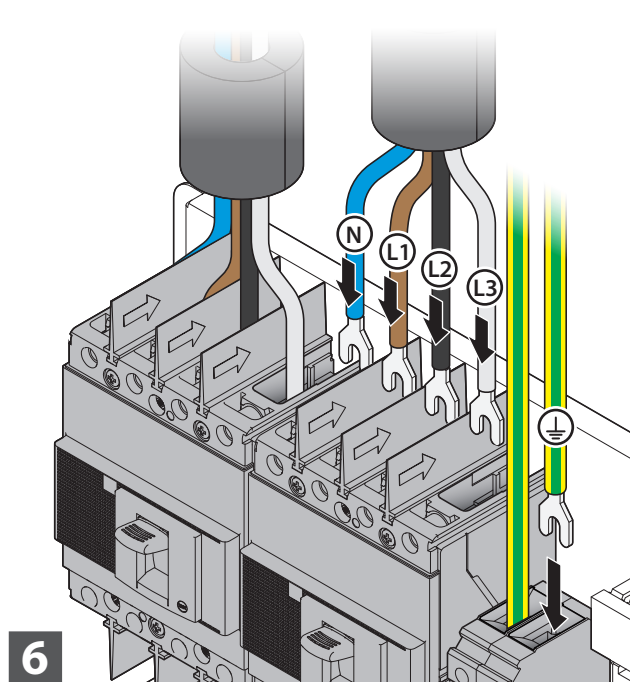
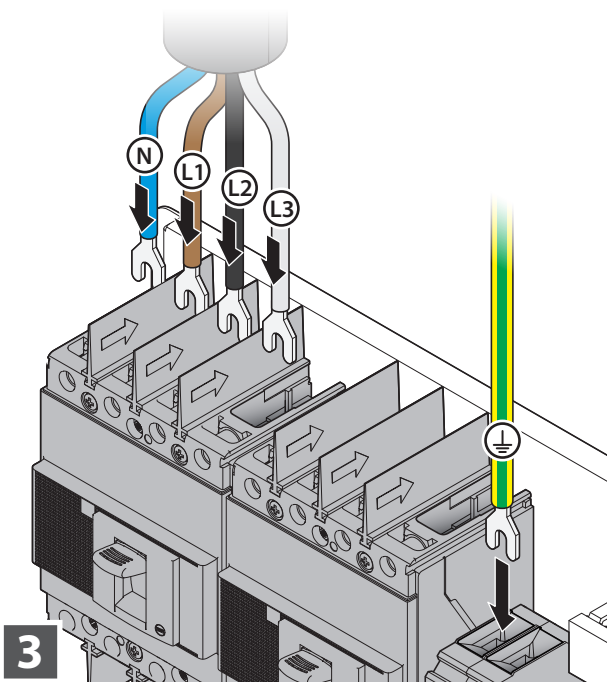
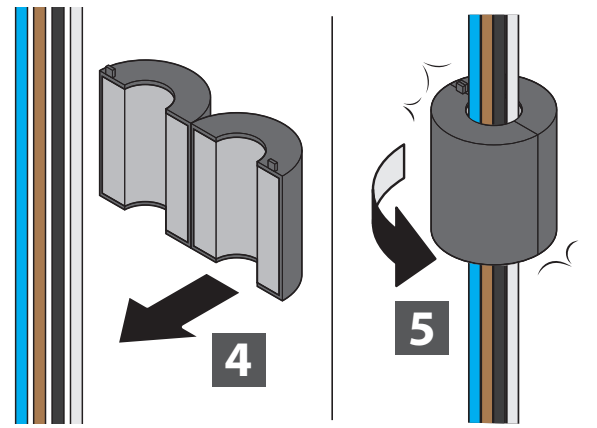

28 Grounding connection

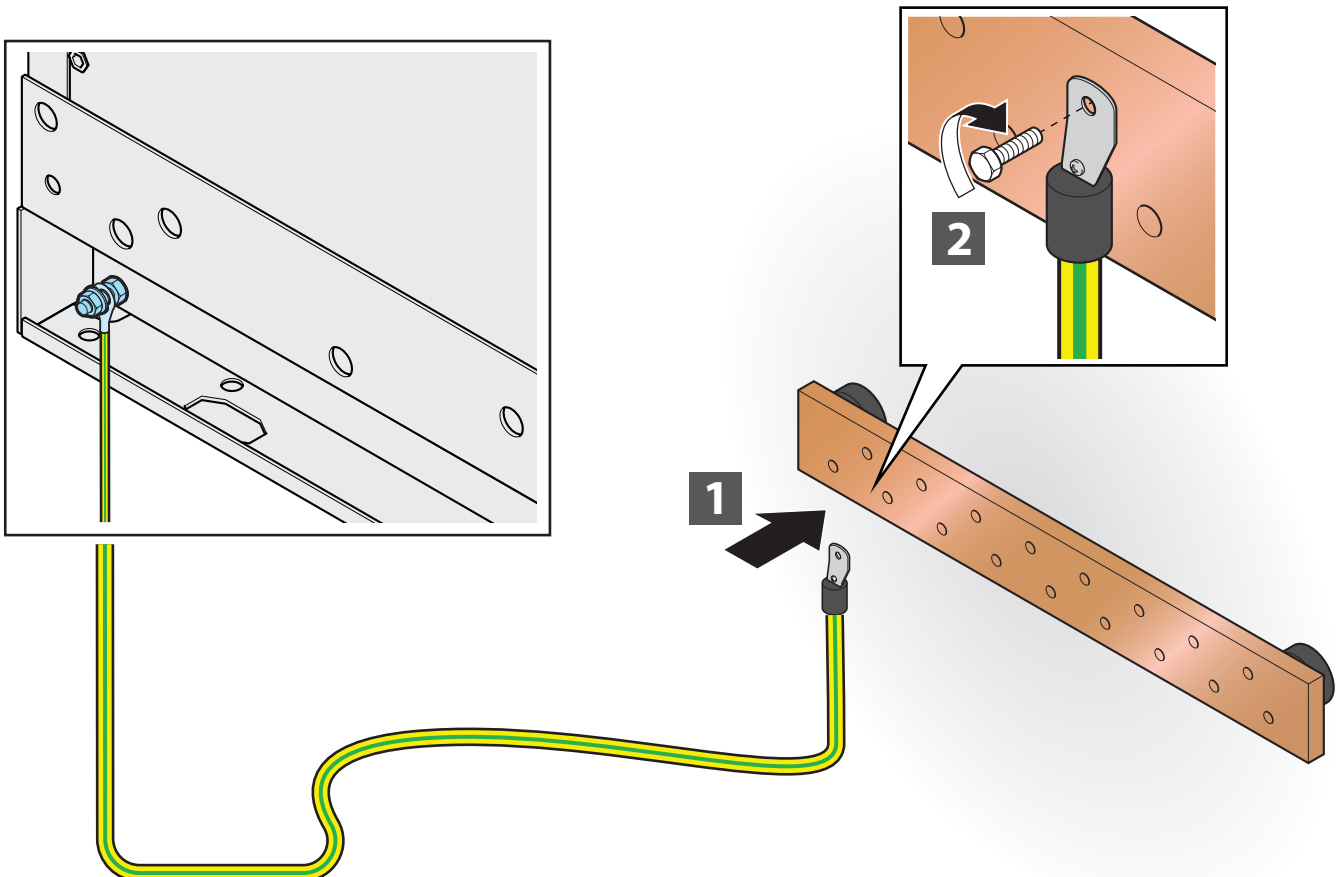
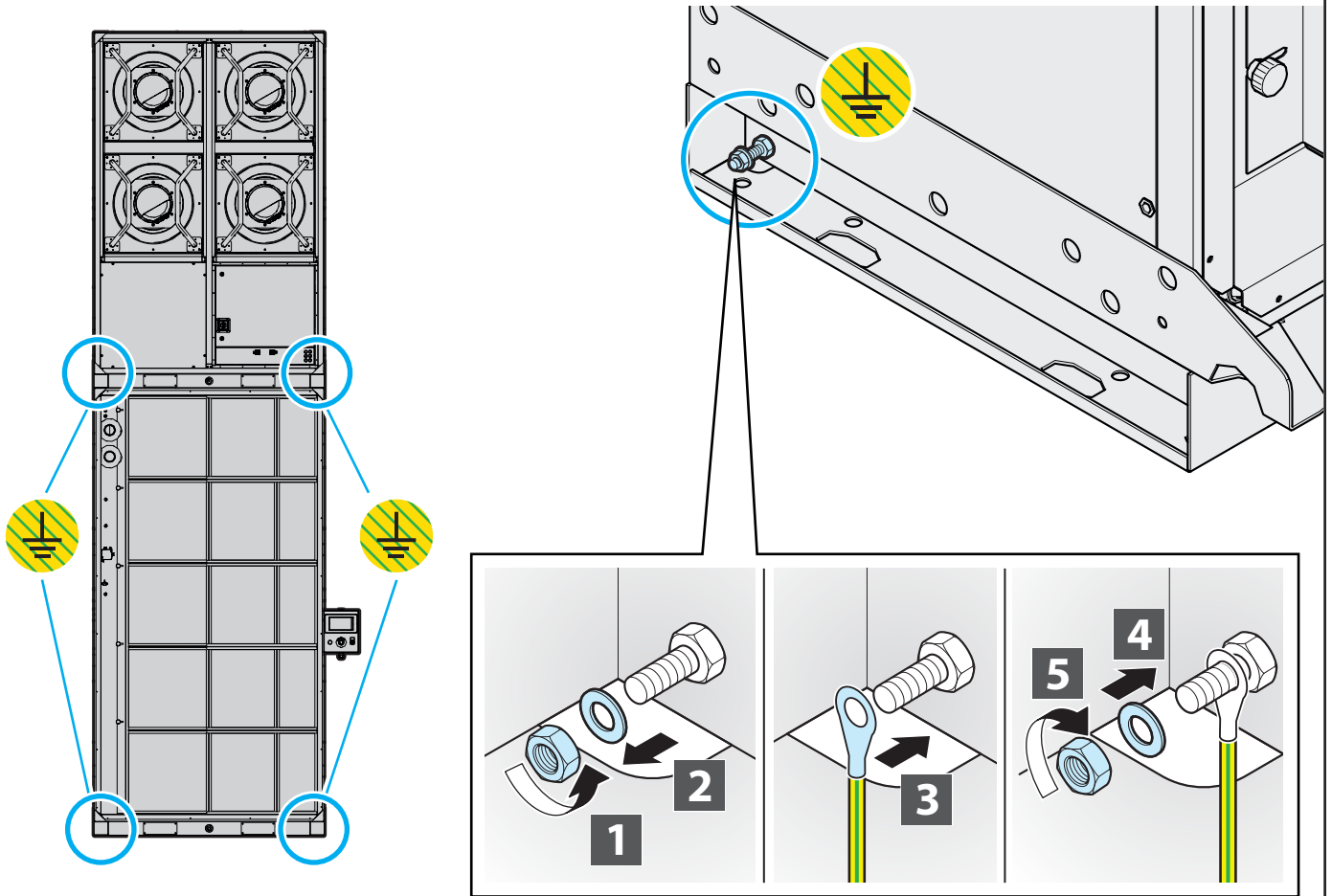

AUXILIARY CONNECTIONS

For completing more connections, feed the cables through the appropriate holes at the bottom left of the panel **1**.

2 Make the necessary connections through the terminal block. For the connections, refer to the wiring diagram provided.

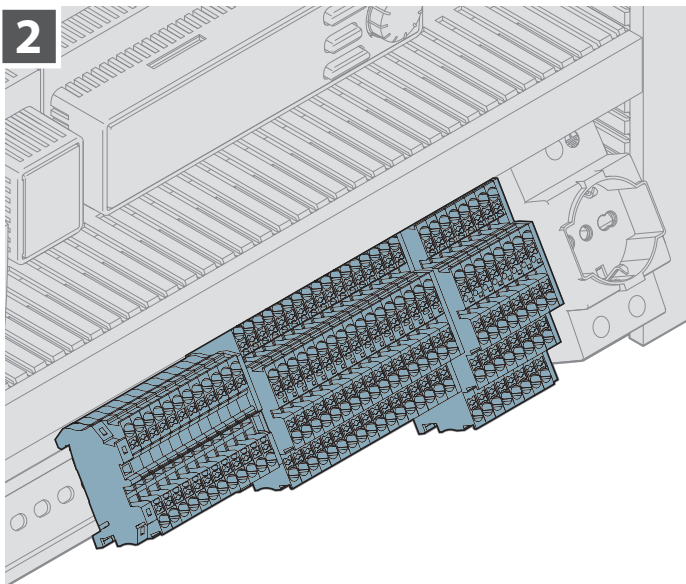
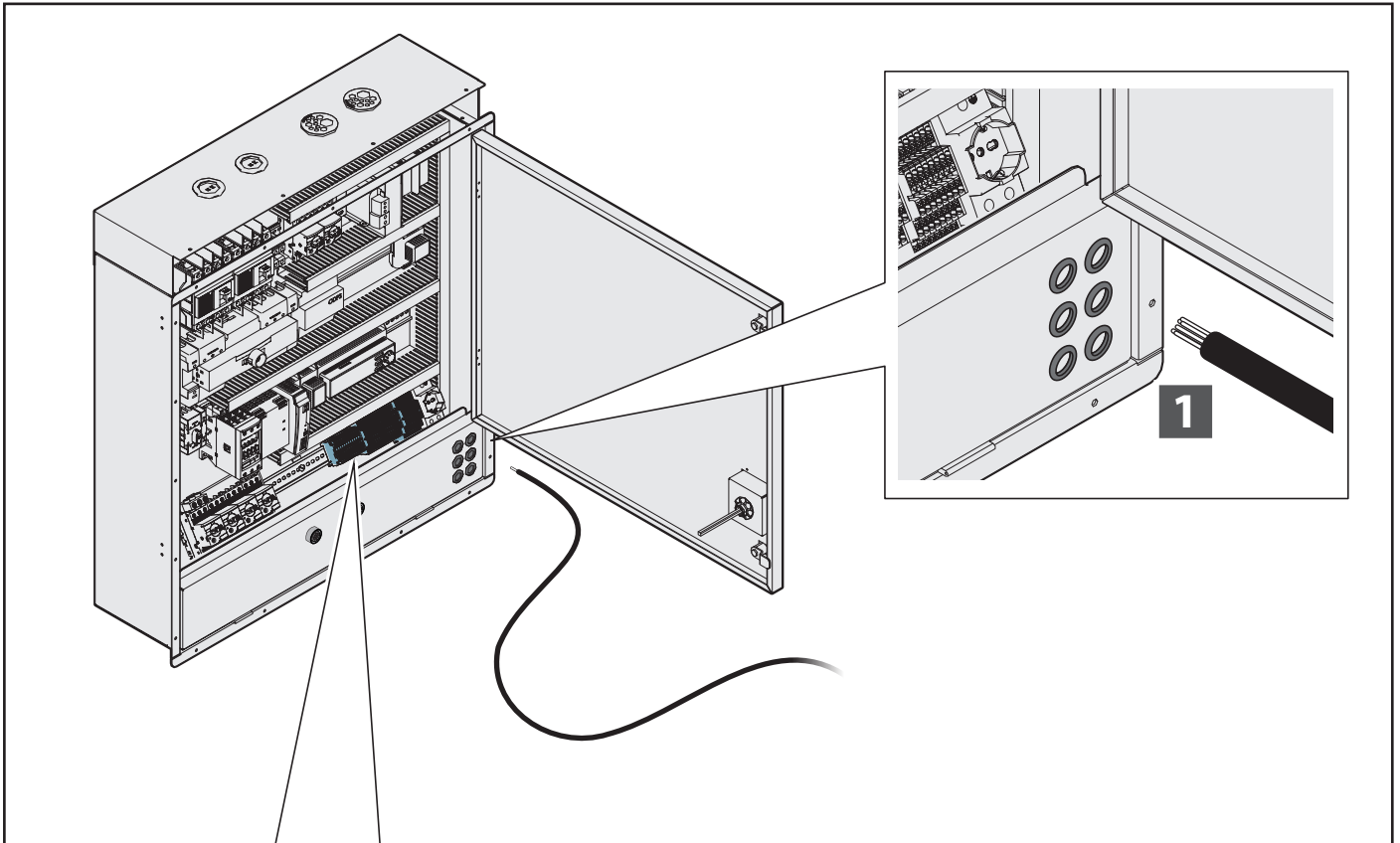

List of Functions

- AHU general alarm (free contact)
- AHU run (feedback unit status)
- Process bus (CE+ / CE-)
- Differential pressure transmitter (room-mounted)
- Fire alarm
- Remote unit enable switch
- 24V spare

For any connections, follow the wiring diagram provided.

PHASE 4: CONNECTION TO A DRAIN

The connection to the drain always requires a siphon between the machine and the drain. For the fittings at the outlet of the drip collection tray, the unit allows for three configurations:

- A. Straight pipe
- B. Pipe with 90° left elbow
- C. Pipe with 90° right elbow

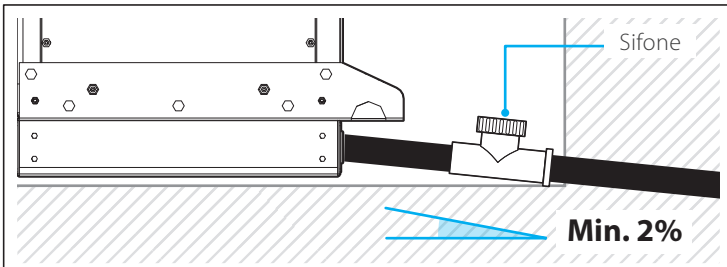

A. Straight pipe

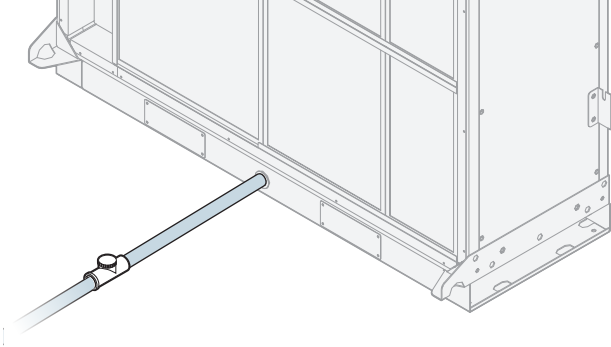

B. Pipe with 90° right elbow

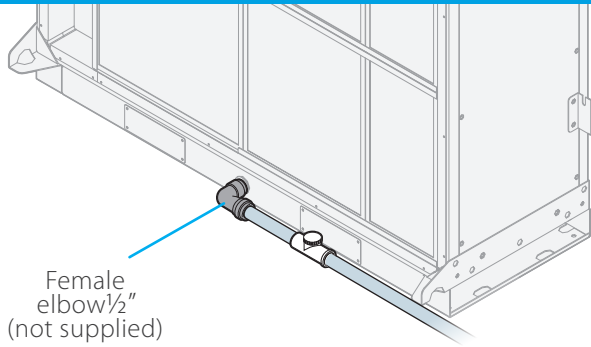

C. Pipe with 90° left elbow

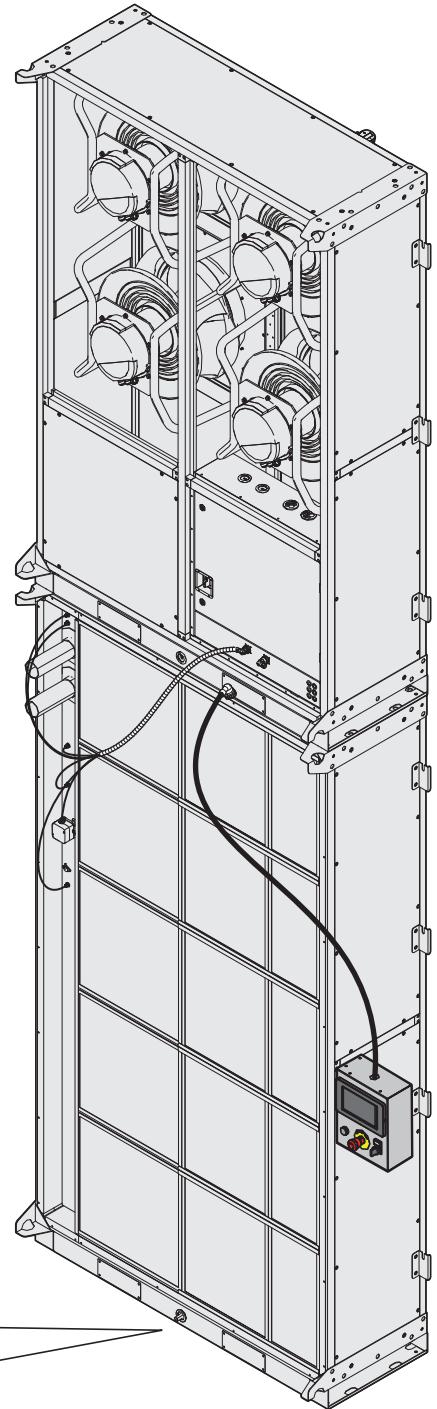
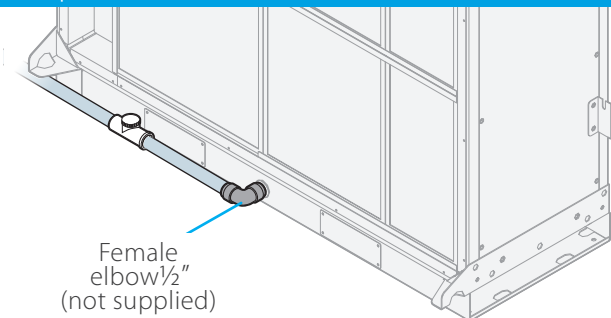

PHASE 5: COIL CONNECTION

29 30 The connection of the coil pipes must be carried out professionally using appropriate sealing materials such as hemp and sealing compound. Additionally, ensure that all fittings are properly tightened to prevent leaks and that the selected sealing material is compatible with the operating conditions, including temperature, pressure, and the type of fluid circulating in the system. Regular inspections and maintenance should be performed to ensure long-term reliability and performance

29 Extension fixing

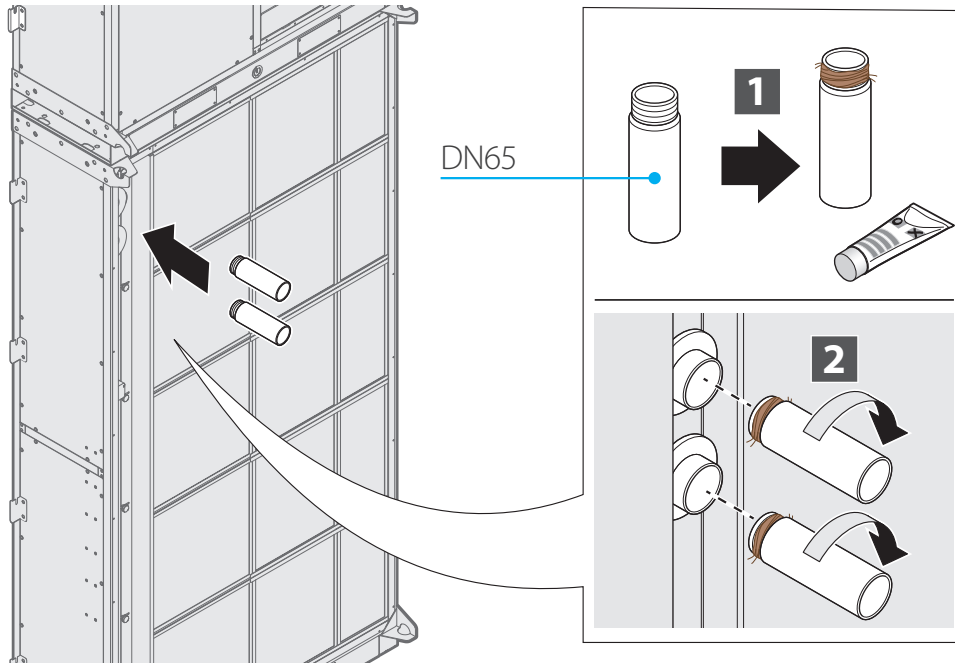

30 Energy valve fixing

The illustration shows the hydraulic connection including valve and fittings. However, depending on the unit configuration and the selected valve type, some fittings may not be required. For confirmation of the actual configuration, always refer to the technical documentation supplied with the unit upon delivery.

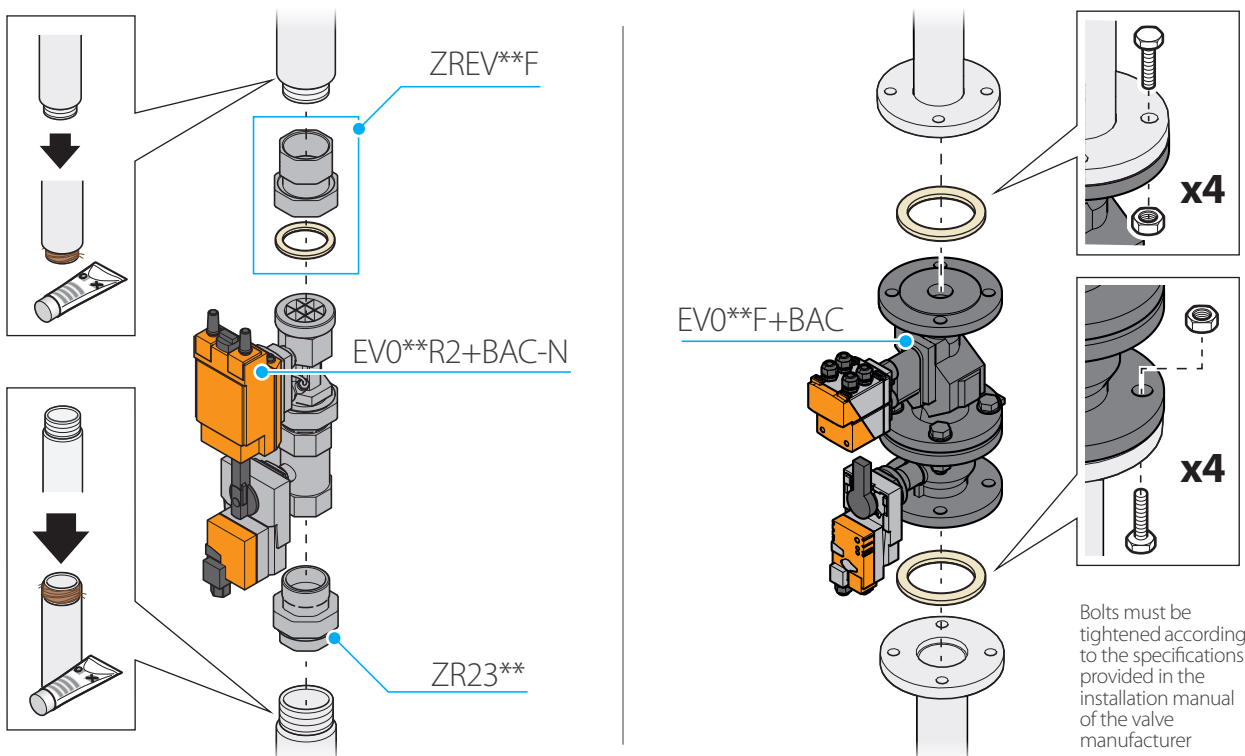

PHASE 6: COMMISSIONING ACTIVITIES

6.1 General

The detailed procedure for operating the control interface is not included in this Installation, Use and Maintenance Manual.

All instructions related to menu navigation, parameter setting, operational modes, alarms and controller behaviour are fully described in the **Operating manual (code: D-EOMAH03812-25EN)**.

The installer **must refer to the Control Interface Appendix** before performing any start up operation.

6.2 Commissioning checklist

To commission the unit it is necessary to (tick with "√" the operations completed):

	check for accurate fluid inlet and outlet pipe connections to the expansion coils
	check that the connections of the inlet and outlet pipes to the coil are leak-free
	check that there is a suitable siphon for all the water being drained.
	check unit integrity.
	check that the electrical connections have been made correctly.
	remove extraneous materials (e.g., assembly sheets, tools, clips, etc.) and dirt (footprints, dust, etc.) from inside the sections.
	verify that PHASES 0–5 have been completed correctly
	verify that all safety devices are installed and active
	ensure the environmental conditions match those specified for operation

6.3 First power-up

1. **Restore power to the unit.**
2. The control interface will initialise automatically.

Any further interaction with the controller must follow the instructions provided in the **Operating manual (code: D-EOMAH03812-25EN)**.

Safety warnings

- Do not operate the unit unless all protective panels and safety devices are correctly installed and secured.
- Do not modify parameters or operating modes unless instructed by the Control Interface Appendix.
- If alarms or abnormal display indications appear, **disconnect power** and identify the cause before proceeding.
- Only qualified personnel may perform start up operations.

6.4 Restart after emergency stop

If the emergency stop (E Stop) has been activated, the unit will remain fully shut down and **will not re-start automatically**.

1. **Reset the emergency stop button** by returning it to the released position.
2. **Restore power to the unit**, if required.
3. Any interaction with the control interface after an E Stop reset must follow the **Control Operating manual (code: D-EOMAH03812-25EN)**.

Safety warnings

- Do not restart the unit until the cause of the emergency stop has been identified and removed.
- Ensure that safe operating conditions have been restored before attempting a restart.
- Only qualified personnel may perform a restart after an emergency stop.
- If any alarm or abnormal condition persists, **disconnect power** and refer to the troubleshooting indications in the Control Interface Appendix.

PERSONAL PROTECTIVE EQUIPMENT

Personal protective equipment should be used when operating the unit, suitable for use in accordance with company criteria and rules.

During the maintenance of the unit, other preventive measures are recommended in addition to the above: safety shoes, gloves, suitable clothing, always compatible with the use and in accordance with company regulations.

TRAINING

It is the responsibility of the unit buyer/user to provide adequate instruction and training to unit operators.

OPTIONAL

In agreed cases, additional training may be provided through the one-on-one instruction of operators by the Manufacturer's technical staff.

7 Maintenance

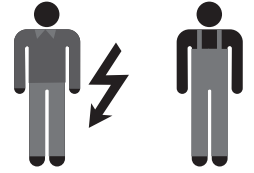

Safety precautions for maintenance



Ordinary and extraordinary maintenance must be carried out **solely by the operator assigned to perform maintenance** (maintenance mechanic and electrician) according to the regulations in force in the country of use and respecting the laws regarding systems and work safety. Remember that, by operator assigned to perform maintenance is meant the person who can work on the unit to perform ordinary and extraordinary maintenance, repairs and fine-tuning. This person must be an expert operator, properly instructed and trained, given the risks involved in such operations.



Before performing any ordinary and extraordinary maintenance, the unit **must always be stopped (by disconnecting from the mains)** and **the EMERGENCY button engaged**. The switch must have a key that must be removed and held by the operator who will perform the operations until the end of the maintenance itself.



It is absolutely prohibited to remove any protections from moving parts and unit protection devices with the unit connected to the power supply or operational. Adjustments made with safety devices disengaged must be performed **by a single person**, expert and authorised, and during this activity it is necessary to prevent access to the area of the unit by other people. Upon completing the adjustments with safety devices disengaged, the protections must be re-engaged as soon as possible.



During maintenance, the operating space surrounding the unit must be free of obstacles, clean and well lit. It is prohibited for unqualified people to pass through or remain in this space.



Use personal protective clothing (safety shoes, safety glasses, gloves, etc.) compliant with regulations.



Before carrying out repairs or other work on the unit, **always declare out loud** your intentions to other operators who are located in the unit area and make sure that they have heard and understood the warning.



Make sure that the inside of the filter is not contaminated by external agents.



Ordinary maintenance

Proper maintenance of the systems maintains efficiency (reducing costs) and consistent performance over time, and increase the usable life of the equipment.

ACTIVITY	FREQUENCY			
	A	B	C	D
General cleaning of the unit.		√		
Replacing the filters (when they have deteriorated).	in case of alarm			
Clean the finned surfaces of the heat exchange coils (if provided) with a compressed air jet and soft brush.	√			
Empty and clean the condensate drain pans.		√		
Visual inspection for corrosion, limescale, release of fibrous substances, any damage, abnormal vibrations, etc. (if possible, it is advisable to extract the components for a more thorough inspection).		√		
Check condensate drain and cleaning of siphons.	√			
Check tightness of screws and bolts in the wall fixing			√	
Check the integrity of all wall fixing points			√	
Check the impeller and various devices, with removal of any buildup.	√			
Check the integrity of piping connected to pressure gauges and pressure switches.		√		
Check the electrical ground connection.		√		
Power connection terminal tightness	√			

A: annual

B: every 6 months

C: every 3 months

D: monthly

GENERAL INFORMATION ON CLEANING PROCEDURES



Read the safety instructions at the beginning of this manual and on page 45



Warning: turn off the unit before ordinary and extraordinary maintenance and wait at least 120 seconds before carrying out any maintenance.



You should consult with your supplier of chemical products to choose the most suitable for cleaning the unit components.



For the cleaning method refer to the instructions of the detergent manufacturer and carefully read the safety data sheet (SDS).

As general guidelines, refer to the following rules:

- always use personal protection (safety shoes, safety glasses, gloves, etc.).
- use mild products (pH between 8 and 9) for washing and disinfecting, in normal concentrations. Detergents must not be toxic, corrosive, flammable or abrasive.
- use a soft cloth or bristle brushes that do not damage the stainless steel surfaces.
- if you use water jets, the pressure should be less than 1.5 bar and the temperature must not exceed 60 °C.
- clean components like motors, damper motors, bearings, Pitot tubes, filters and electronic sensors (if applicable), do not spray water directly on them.
- after cleaning make sure that you have not damaged the electrical parts and the gaskets.
- cleaning operations should not involve the lubricated parts, like impeller shafts, because this could affect their good operation and create problems with durability.
- for the cleaning of finned components or dampers use an industrial vacuum cleaner and/or a compressor. Attention, the compressed air flow must run opposite to the direction of air flow through the unit.
- to clean plastic components such as tapping points, grommets, cable glands, connecting tubes and clicks, use a cloth soaked in alcohol. We recommend carrying out the operation during the general cleaning of the unit and when replacing the filters. If cleaning with the alcohol-soaked cloth is insufficient, replace the plastic components

VENTS

Periodically check that there are no new sources of contamination near the air intake. Each component must be checked periodically for the presence of contamination, damage and corrosion. The gasket can be protected with glycerine-based lubricants or replaced with a new one, if worn.

FAN ASSEMBLY



The unit must be disconnected from the power supply when cleaning the fans.

Fans can be cleaned with compressed air or by brushing them with soap and water or with a neutral detergent.

Finish the cleaning by rotating the fan by hand to verify the absence of abnormal noises.

FILTER REPLACEMENT



The unit must NOT be running when the filters are removed to avoid drawing in outside air that might be contaminated.

31 Filters should be replaced every 3-4 months. Remove them following the procedure shown in the figure, extract the new filters from the packaging (in which they are supplied to avoid deterioration during transport and stay on site), insert them in the special containment section, paying attention to their correct positioning.



Remove the filters from their packaging only when ready to install them to avoid getting them dirty and contaminating them.

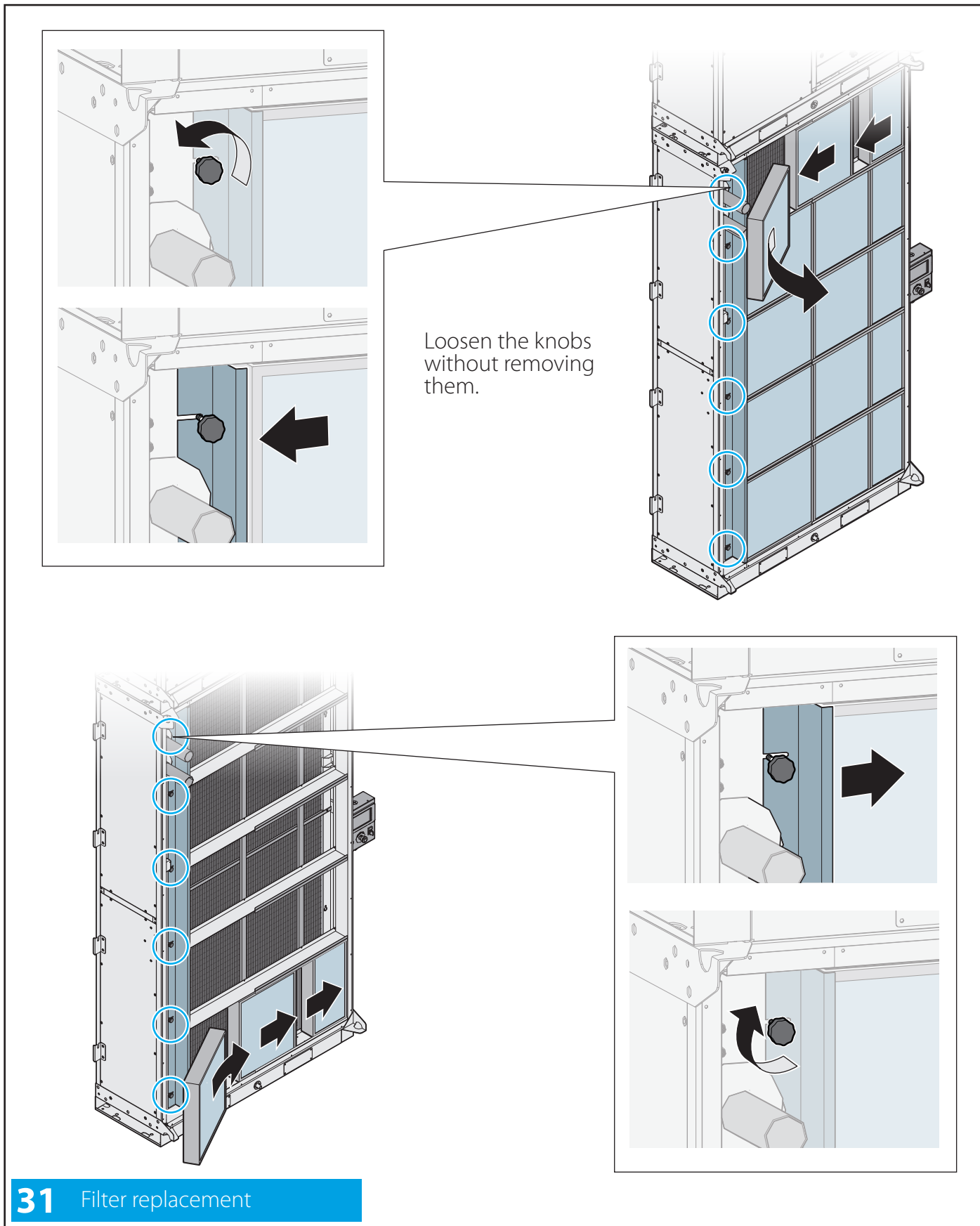



This operation should be carried out about one hour after the first start-up of the unit, the period during which the ducts are cleaned of dust and various debris. Proceeding in this way preserves the filtering sections that cannot be regenerated.

Extraordinary maintenance



Turn off the unit before routine maintenance and wait at least 120 seconds before performing maintenance.

One cannot predict extraordinary maintenance as it is normally due to effects of wear or fatigue caused by the incorrect operation of the unit.

REPLACEMENT OF PARTS



The replacement of parts should be performed by expert personnel:

- qualified maintenance mechanic
- qualified maintenance electrician
- manufacturer technician

The unit is designed to be able to perform all the servicing necessary to maintain good efficiency of the components. However, it sometimes happens that a component fails due to malfunction or wear, so for replacement refer to the executive drawing.

These are the components that may need replacement:

- filters
- fans

For some of these operations of a general nature we will not enter into detail as these are operations that fall within the abilities and professional expertise of the staff assigned to perform them.

CONSUMABLE COMPONENTS - SPARE PARTS

During the operation of the unit there are particular mechanical and electrical components that are most subject to wear. These parts must be monitored in order to carry out their replacement or repair before they cause problems to the correct operation of the unit with consequent downtime.

Disposal of used materials - waste



The unit is made with metal, plastic and electronic components.

All these components must be disposed of in compliance with local disposal laws and, where applicable, with those transposing Directive 2012/19/EU (WEEE).

Diagnostics

GENERAL DIAGNOSTICS

The unit's electrical system includes quality electromechanical components and is therefore extremely durable and reliable over time.

Should there be any malfunctions due to malfunctions of electrical components it will be necessary to act as follows:

- check the fuses of the power supply for the control circuits and if necessary replace them with fuses having the same specifications.
- check if the thermal protection switch for the motor has been triggered or if its fuses have blown.

If this has occurred, it may be caused by:

- motor overload due to mechanical problems. They need to be solved.
- incorrect supply voltage. Verify the protection trip threshold.
- malfunction and/or short circuits in the motor. Identify and replace the failed component.

ELECTRICAL MAINTENANCE

Do not modify the unit for any reason and do not add other devices.

The manufacturer is not liable for resulting malfunctions and problems.

Further clarification is available by contacting the manufacturer's Customer Service.

Troubleshooting table

MALFUNCTION TYPE	COMPONENT	POSSIBLE CAUSE/SOLUTION
NOISE LEVEL	Fan impeller	Impeller deformed, unbalanced or loose
		Nozzle damaged
		Foreign bodies in the fan
	Motor	Incorrect supply voltage
		Worn bearings
		Contact between the rotor and stator
Ducts (units with ducts and spigots only)	Excessive speed in the ducts	
INSUFFICIENT AIR FLOW	Ducts	Load losses superior to the demand
		Obstructions in the ducts
	Filters	too dirty
Heat exchange coils	too dirty	
EXCESSIVE AIR FLOW	Ducts	Load losses inferior to the demand
		Ducts too large
		Terminals not installed
	Unit	Filters not inserted
		Access doors open
INSUFFICIENT THERMAL EFFICIENCY	Heat exchange coil	Incorrect connection of inlet/outlet piping
		Heat exchange coil dirty
		Air bubbles in the pipes
		Excessive air flow
	Fluid	Temperature different from the project
		Incorrect regulation bodies
WATER LEAK	Fan section	Leak from the coil due to corrosion
		Dragging of drops due to high air velocity
		Clogged "overflow" drain

DAIKIN APPLIED EUROPE S.p.A. Via Piani S. Maria, 72 - 00072 Ariccia (Rome) Italy - www.daikinapplied.eu



This publication is drawn up only as a technical support and does not constitute a binding commitment for Daikin Applied Europe S.p.A. Daikin Applied Europe S.p.A. has drawn up the content to the best of its ability. No explicit or implicit guarantee is given as to the completeness, precision or reliability of its content. All the data and specifications contained herein are subject to change without notice. The data stated at the time of the order prevail. Daikin Applied Europe S.p.A. accepts no liability whatsoever for any direct or indirect damage, in the broadest sense of the word, deriving from or associated with the use and/or interpretation of this publication.
All content is protected by the copyright of Daikin Applied Europe S.p.A.

D-EIMAH03806-25_01EN