



Installation, use and
maintenance manual

Compact L

D-EIMAH03411-24_00EN

- › Compact L Pro
- › Compact L Smart

Translation of the original instruction

REV	00
DATE	November 2024
SUPERSEDES	

The Compact L heat recovery units guarantee high internal air quality with low energy costs. The range of items is divided into six sizes, customisable with the addition of external optional.

Armed with an extremely flexible development, Daikin air handling units are able to satisfy all types of technical requirements.

Daikin systems guarantee respect for the environment since they are based on high levels of energy efficiency. Reduced ecological impact and low energy consumption make Daikin recovery units ideal for any type of market.

Contents

Assembly instructions

Important warnings 3

Purpose of the manual	4
Intended use of the unit	4
Important warnings	4
Safety regulations	5
Residual risks	8
Safety devices	9
Environmental conditions	10
Environmental contamination	10
Noise	10

Unit characteristics 10

Ceiling and air duct specifications	11
Technical data	12
Preheating external coil	12
Summary of unit operation	14
Unit with left orientation	14
Unit with right orientation	14

Receipt of the cartons 15

Transport 16

After unpacking	17
Unpacking and integrity check	17
Product nomenclature	18
Storage waiting for installation	19

Installation 20

Installation procedure	20
Configuration	32
Commissioning	32

Maintenance 50

Safety precautions for maintenance	50
Ordinary maintenance	51
General information on cleaning procedures	52
Correct filter and pre-filter installation	55
Extraordinary maintenance	56
Replacement of parts	56
Consumable components - Spare parts	56

Diagnostics 59

General diagnostics	59
Electrical maintenance	59
Troubleshooting table	60
Optional connection - assembly instruction	61
Repair log	69

1 Important warnings



The pictogram shows a situation of immediate danger or a dangerous situation that might cause injuries or death.



The pictogram shows that it is necessary to adopt suitable behaviour in order to avoid jeopardising staff safety and cause damages to the equipment.



The pictogram shows particularly important technical information that should be taken into consideration by the people installing or using the equipment.

Purpose of the manual

The purpose of this **manual** is to guide the installer and qualified operator in the installation, maintenance and proper and safe use of the equipment. For this reason, **it is mandatory for all personnel involved in installation, maintenance and supervision of the unit to read this manual.**

Contact the manufacturer if any points are unclear or difficult to understand.

This manual contains information regarding:

- Technical specifications of the unit.
- Instructions for transport, handling, installation and assembly.
- Use.
- Information for instructing personnel authorised for its use.
- Maintenance activities.

All information refers in general to any unit of the Compact L range. All the units are shipped together with a **technical schematic** indicating the specific weight and size of the unit received. It must be considered an integral part of this manual and therefore it must be kept with the utmost care in all its parts.

If the manual or drawings are lost, please request a new copy from the manufacturer, specifying the unit serial number as specified on the label on the unit.

In the case of divergent information between this manual and the schematic, the schematic will prevail.

Intended use of the unit

This appliance has the function of treating the air intended to condition civil and industrial environments. Any other use is not in accordance with the intended use and therefore dangerous.

This range of units is designed to be used in NON-explosive environments.

If the unit is used in critical situations, by type of system or environmental context, the customer must identify and adopt the technical and operational measures to avoid damage of any kind.

Safety regulations

Skills required for the installation of the unit



Installers must perform operations according to their professional qualifications: all activities not within one's expertise (i.e. electrical connections) must be carried out by specialised and qualified staff so as not to endanger one's safety and the safety of the other operators interacting with the unit.



Transport and equipment handling operator: authorised person with recognised expertise in using transport and lifting equipment.



Technical installer: expert technician, sent or authorized by the manufacturer or its representative, with adequate skills and training to install the unit.

Assistant: technician subject to care obligations while lifting and assembling the equipment. He must be suitably trained and informed about the operations to perform and the safety plans of the site/installation location.

In this manual, the technician competent to carry out each operation is specified.

Skills required for the use and maintenance of the unit



Generic operator: AUTHORISED to run the unit using commands placed on the keypad of the electrical control panel. Performs only unit control operations, power on/off.

Maintenance mechanic (qualified): AUTHORISED to carry out maintenance, adjustments, replacement and repair of mechanical parts. It must be a person competent in mechanical systems, therefore able to perform mechanical maintenance in a satisfactory and safe manner, must possess theoretical preparation and manual experience. NOT AUTHORISED to work on electrical systems.

Manufacturer's technician (qualified): AUTHORISED to perform complicated operations in every situation. Operates in accordance with the user.



Maintenance electrician (qualified): AUTHORISED to perform service of an electric nature, adjustments, maintenance and electrical repairs. AUTHORISED to operate in the presence of an active electrical connection inside the control panels and junction boxes. It must be a person competent in electronics and electrical engineering, therefore able to work on electrical systems satisfactorily and safely, must possess theoretical knowledge and proven experience. NOT AUTHORISED to work on mechanical systems.



Installers, users and maintenance technicians may NOT operate on the unit if:

- they are not experienced or responsible or if they are minors;
- they have a physical disability or are not in perfect physical/psychological condition;
- they are not skilled in managing the unit operating cycle;
- they have not taken part in theoretical/practical preparation training alongside an expert unit operator or controller, or alongside one of the manufacturer's technicians.

In this manual, the technician competent to carry out each operation is specified.



Read this manual carefully before unit installation and maintenance and keep it for any further future consultation by the various operators. Do not remove, tear out or rewrite any part of this manual.



All installation, assembly, electrical connections and standard/non-standard maintenance must be carried out solely by **technicians who comply with legal requirements**, only after turning off the power supply to the unit, and only using personal protective equipment (e.g. gloves and protective eyewear), in compliance with the standards in force in the country where the unit is used, and in compliance with the regulations on systems and safety in the workplace.



Installation, use or maintenance other than those specified in the manual may cause damage, injury or death, invalidate the warranty and relieve the Manufacturer of any liability.



Use protective clothing and suitable equipment while handling or installing the equipment, in order to prevent accidents and safeguard your own and other people's safety. Individuals not assigned to installation or maintenance are NOT allowed to stand or pass through the work area while the unit is assembled.



Disconnect the equipment from the mains before installing or maintaining it.



Before installing the equipment, check that the systems comply with the legal provisions in force in the country of use and meet the specifications on the serial number plate.



It is the responsibility of the user/installer to check the static and dynamic stability relative to the installation and to arrange environments so that **people who are not competent or authorised DO NOT have access to the unit or to its commands**.



It is the responsibility of the user/installer to make sure that **weather conditions** do not affect the safety of persons and property during installation, use and maintenance.



Make sure the air intake is not located near any exhausts, flue-gases or other contaminating elements.



Do not install the equipment in places exposed to strong winds, salt air, open flames or temperatures exceeding 40°C (104°F).



After installation is complete, instruct the user on the correct use of the unit.

If the equipment does not work or functional or structural alterations are noted, disconnect it from the mains and contact a service centre authorised by the Manufacturer or Retailer, without attempting to repair it on your own. For any replacements request the use of original spare parts.

Unauthorised actions, tampering or modifications that do not follow the information provided in this manual can cause damage, injuries or fatal accidents and void the warranty.

The serial number plate on the unit provides important technical information, essential in case of unit maintenance or repairs. We recommend that you do not remove, damage or modify it.

In order to ensure correct and safe conditions of use, it is recommended to have the unit maintained and checked at least annually by a service centre authorised by the manufacturer or dealer.

Failure to follow these instructions may cause damage and injuries, even fatal, voids the warranty and relieves the Manufacturer of any liability.

Residual risks

Despite having implemented and adopted all the safety measures indicated by applicable regulations, some residual risks remain. In particular, in some operations of replacement, adjustment and tooling maximum attention is always required in order to work in the best possible conditions.

List of operations with residual risks

Risks for qualified personnel (electrician and mechanic)

- Handling - during unloading and handling it is necessary to pay attention to all the steps listed in this manual regarding the points of reference
- Installation - during installation it is necessary to pay attention to all the steps listed in this manual regarding the points of reference
The installer must ensure the static and dynamic stability of the unit's site of installation.
- Maintenance - during maintenance it is necessary to pay attention to all the steps listed in this manual, and in particular to high temperatures that may be present in the heat transfer fluid lines to/from the unit.
- Cleaning - the unit must be cleaned only when it is switched off, by turning off the switch installed by the electrician and the switch located on the unit itself. The key for interrupting the power supply must be kept by the operator until the end of the cleaning operations. Internal cleaning of the unit must be carried out using the protections required by current regulations. While the inside of the unit does not contain particular hazards, it is necessary to pay the utmost attention so that accidents do not occur during cleaning. The heat exchange coils that have a potentially sharp finned pack must be cleaned using protective glasses and gloves suitable for handling metals.

During adjustment, maintenance and cleaning there are residual risks of variable entity. Being operations that must be performed with guards disabled, it is necessary to pay particular attention in order to avoid damage to persons and things.



Always pay close attention when performing the operations specified above.

Remember that these operations must always be performed by authorised personnel.

All work must be completed in accordance with the legal provisions relating to work safety.

Remember that the unit in question is an integral part of a larger system that includes other components, depending on the final characteristics of realisation and the mode of use. Therefore in the end it is the responsibility of the user and assembler to assess the residual risks and their respective preventive measures.

Safety devices



The unit is equipped with safety devices to prevent risks of damage to persons and for proper operation. Always pay attention to the symbols and safety devices on the unit. It should **only** operate with the safety devices engaged and with fixed or movable guards installed correctly and in the proper position.



If during installation, use or maintenance the safety devices have been temporarily removed or disabled, the unit can be operated **exclusively** by the qualified technician who made this change. It is **mandatory** to prevent other people's access to the unit. When finished, restore the devices to their proper status as soon as possible.

2 Unit characteristics

Environmental conditions



Compact L heat recovery units are designed for use in indoor environments, installed on the ceiling. The unit cannot operate in environments containing explosive material and with a high concentration of dust.



	SMART	PRO
Outside air temperature	<ul style="list-style-type: none"> - 5°C + 46°C without preheating - 21°C + 46°C with preheating* <p>*Note: it is mandatory that the inlet temperature is above -5°</p>	<ul style="list-style-type: none"> - 38°C + 46°C** <p>**Note: from -16° is recommended a preheating (water or electric)</p>
Operating environment temperature	+5°C to +46°C	
Temperature of the environment with the unit off (e.g., storage, transport, etc.)	from -40°C to +60°C	

Thanks to its modularity, each unit is able to adapt to different needs in terms of air flow and thermodynamic treatments.

The optimised choice of every detail, the search for maximum efficiency in each component, the adoption of specific materials and constructive solutions transform environment friendliness and energy savings into valid and advanced technological solutions.

Environmental contamination

Depending on the installation operating environment, specific regulations must be followed and all the necessary precautions must be taken to avoid environmental issues (a system that operates in a hospital or chemical environment can have problems different from those in other sectors, even from the point of view of disposal of consumable parts, filters, etc.).

It is mandatory for the buyer to inform and train workers regarding proper procedures.

Noise



The units have been designed and manufactured in such a way as to produce sound emissions below the threshold of **80 dB(A)**. It should be noted that every environment has its own acoustic characteristics that can greatly affect the pressure values perceived during operation, therefore it is necessary to consider the noise data provided as a point of reference, while it is up to the buyer to carry out the specific phonometric surveys on the installation site and in the real conditions the unit will be used.

Ceiling and air duct specifications

The **ceiling** where you plan to install the unit **must** be:

- perfectly flat and without roughness;
- vibration resistant;
- able to **support the weight of the equipment considering an appropriate safety margin** see table of technical data on page 12).

The equipment installed on the ceiling can adapt easily to the presence of a false ceiling.

In fact, without sufficient space for up-and-over door opening, the inspection door can be transformed into a panel able to slide on accessory guides (optional accessory).

If provided, the **air ducts** must be connected directly to the unit, taking care to insert an optional accessory as a suitable anti-vibration system between the unit itself and the duct. When assembly is completed they must not be taut, in order to avoid damage and transmission of vibrations.

To ensure the seal of the connections and the integrity of the unit, it is essential that the air ducts be supported by special brackets that do not weigh directly on the unit.

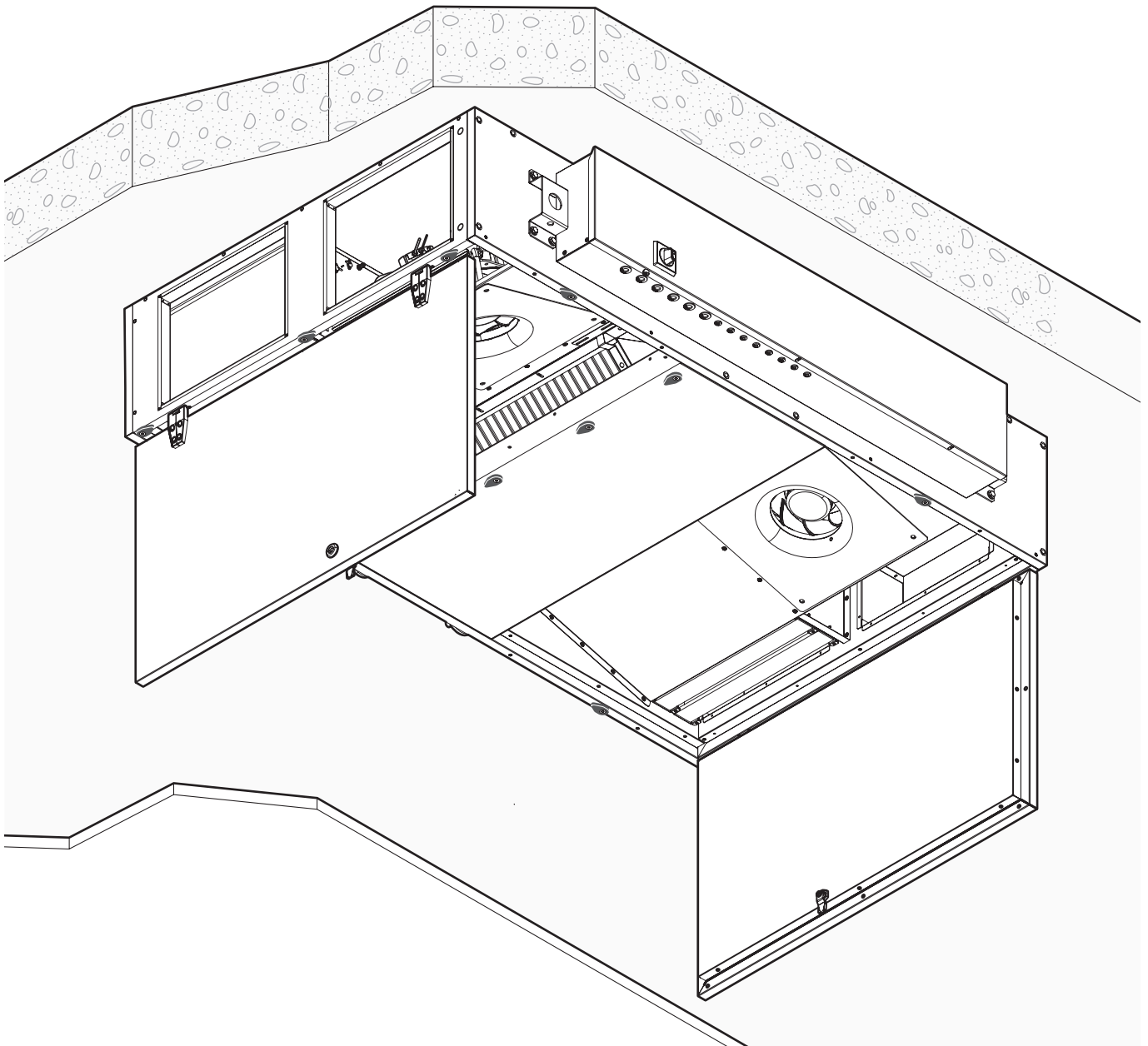

Technical data

TECHNICAL DATA TABLE	SIZE						
		2	3	4	5	6	7
Nominal air flow rate	m ³ /h	300	600	1200	1500	2500	3000
Heat efficiency	%	78	80	80	79	75	74
FLA	A	2.9	4.5	4.5	4.7	7.1	11.7
FLI	W	371	1033	1033	1073	1633	2733
Electrical connection		200-277 V, 1 ph					

WEIGHT TABLE	SIZE						
		2	3	4	5	6	7
Gross weight with packaging	kg	125	180	270	280	325	335
Device weight	kg	115	170	255	265	310	320
Door weight	kg	2x9.0	2x9.0	2x16.0	2x16.0	2x19.0	2x19.0
Drain pan panel weight	kg	1x6.5	1x13.0	1x17.0	1x17.0	1x20.0	1x20.0
Filter weight	kg	2x0.2	2x0.3	2x0.5	2x0.5	2x0.5	2x0.5
Fan weight	kg	2x2.0	2x8.5	2x8.5	2x9.0	2x15	2x17
Heat exchanger	kg	1x9.0	1x13.0	2x19.0	2x19.0	2x19.0	2x19.0

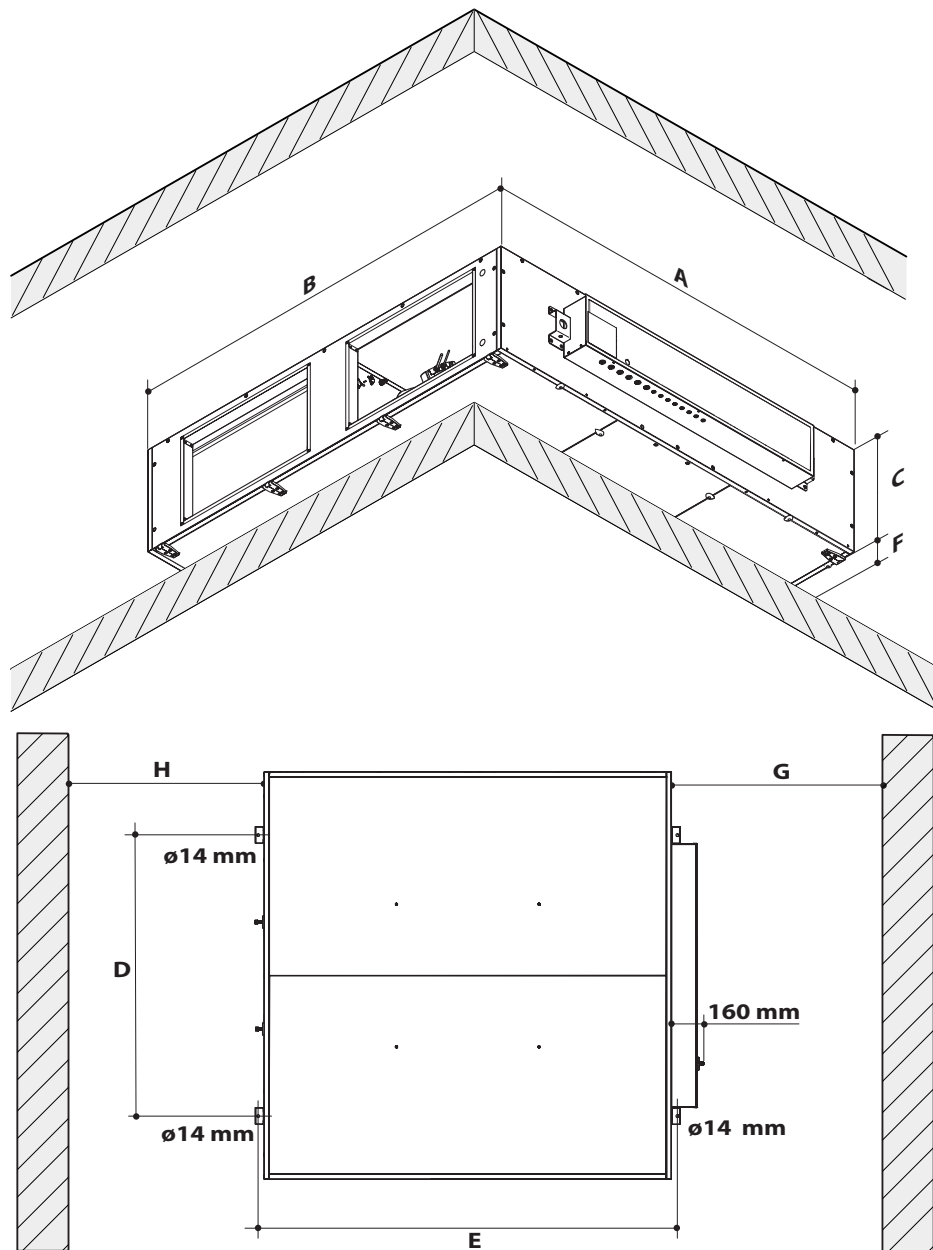

TECHNICAL DATA TABLE	SIZE						
		2	3	4	5	6	7
Length (A)	mm	1660	1800	2000	2000	2000	2000
Width (B)	mm	920	1100	1600	1600	2000	2000
Height (C)	mm	280	350	415	415	500	500
Hole distance (D)	mm	1380					
Hole distance (E)	mm	976	1156	1656		2056	
F (up-and-over doors)	mm	630	670	675			
F (sliding doors)	mm	70					
G	mm	500					
H	mm	300					

Summary of unit operation

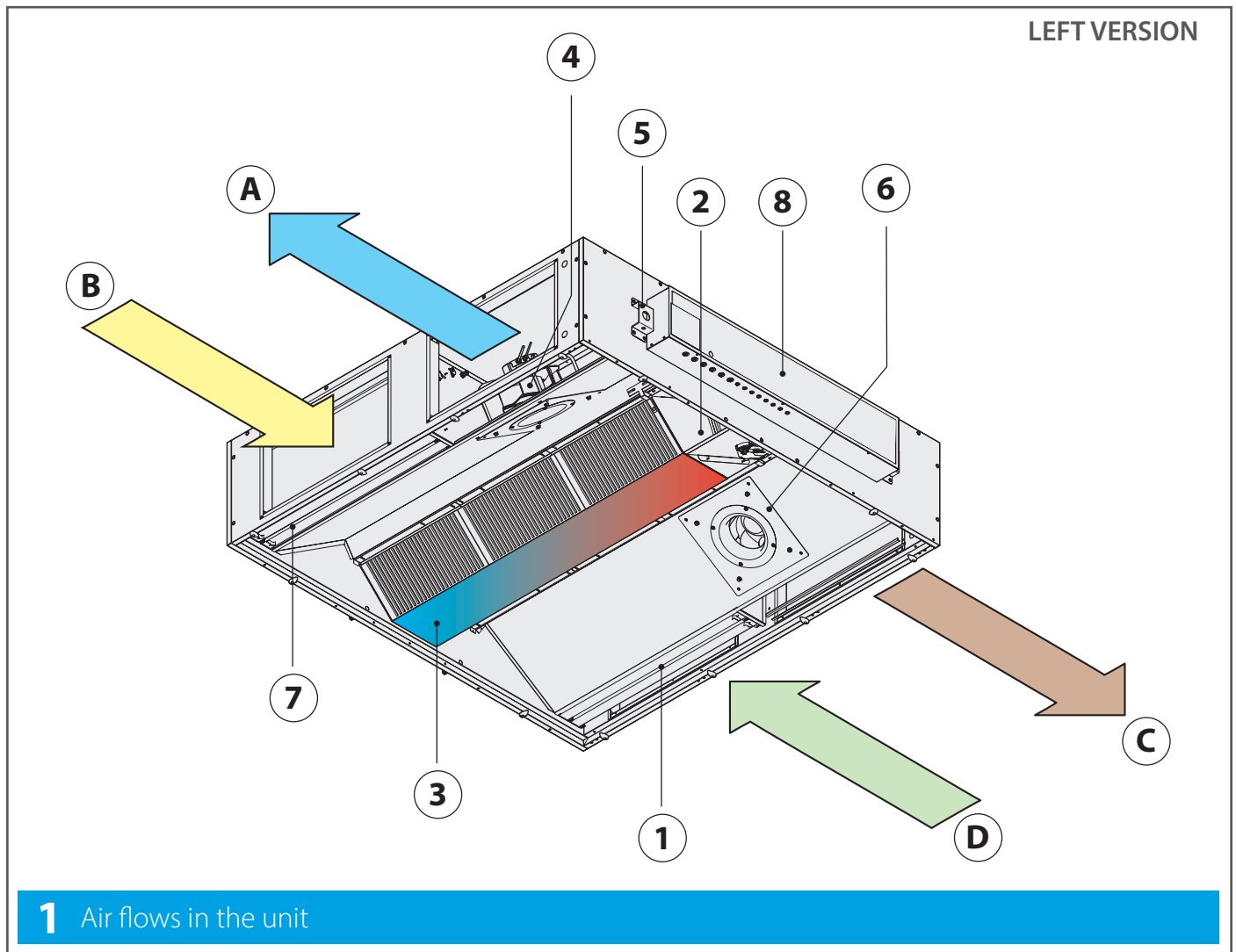

Unit with left orientation

- | | |
|----------------------------|---------------|
| ① Supply filter | Ⓐ Supply air |
| ② Bypass damper | Ⓑ Return |
| ③ Heat exchanger | Ⓒ Exhaust air |
| ④ Return fan | Ⓓ Fresh air |
| ⑤ Ceiling locking brackets | |
| ⑥ Supply fan | |
| ⑦ Return filter | |
| ⑧ Control box | |

Unit with right orientation

- | | |
|---------------------------------|---------------|
| ① Filter and pre-filter | Ⓐ Exhaust air |
| ② Exchanger by-pass | Ⓑ Fresh air |
| ③ Heat exchanger | Ⓒ Supply air |
| ④ Supply motor-driven fan group | Ⓓ Return |
| ⑤ Ceiling locking brackets | |
| ⑥ Return motor-driven fan group | |

Pos.	Component name	Construction material
1	Filter	galvanised steel frame, synthetic filter unit
2	Bypass	aluzinc
3	Heat exchanger	aluminium
4	Fan motor assembly	size 2: composite board frame and impeller size 3,4,5,6,7: steel frame, composite board impeller
5	Brackets	galvanised steel

3 Receipt of the cartons



Handle the equipment following the Manufacturer's instructions on the packaging and in this manual. Always use personal protective equipment.

The means and method of transport must be chosen by the transport operator according to the type, weight and size of the unit. If necessary, draw up a "safety plan" to guarantee the safety of the people directly involved.



Upon receipt of the unit check the integrity of the packaging and the amount of parcels sent:

A) There is visible damage/one or more cartons is missing: **do not** install, but **promptly** notify the Manufacturer and the carrier that made the return.

Alternatively you can accept the shipment "subject to verification": this will make it possible to open the cartons and check if the internal components are indeed damaged. In the latter case, as noted previously, **promptly** notify the Manufacturer and the carrier that made the return.

Before opening the cartons, it is recommended to take good quality pictures to document the damage.

B) There is NO visible damage: move the unit to the site of installation.

4 Transport



Packages can be handled with a pallet truck of suitable capacity or with a forklift. The choice of the most suitable means and method lies with the operator.



The operating area must be perfectly free from objects or people not involved in the transport.



If transport is done using a pallet truck make sure it is suitable for the weight and size of the unit. Insert the forks into the points provided for handling (usually in a central position) so as to keep the centre of gravity of the load in balance. Move the equipment carefully, avoiding sudden movements.



5 Unpacking and integrity check



We recommend the equipment be unpacked after moving it to its installation location and only when it is to be installed. This operation must be performed using personal protection equipment (i.e., gloves, safety shoes, etc.).



Do not leave the packing unattended: it is potentially harmful to children and animals (suffocation hazard).



Some packing materials must be kept for future use (wooden crates, pallets, etc.), while those that cannot be reused (i.e., polystyrene, strapping, etc.) must be disposed of in compliance with the regulations in force in the country of installation: this will protect the environment!

After unpacking

After unpacking, check the received contents:

- Ambient thermostat
- Installation and maintenance manual (IOM)
- Wiring diagram
- Declaration of conformity

Check therefore that you have received all the components and that they are undamaged

In case of damaged or missing parts.

- **do not move, install or repair** damaged components and the unit in general;
- **take quality photos** to document the damage;
- **find the serial number plate** on the unit and note the unit serial number;
- immediately **notify** the carrier that delivered the unit;
- **promptly** contact the Manufacturer (keep on hand the serial number of your unit).



Please note that complaints or claims of damage reported after 10 days of receipt of the unit cannot be accepted.

DAIKIN

AHU Codifica / Product number: **D** ALB07LBMNADBT00 POS Code: A83665

Matricola / Serial number: **I** 18C0144 Data / Date: **E** 4/2018 Peso / Weight: **C** 373

PORTATA ARIA / AIR FLOW **B**

Mandata / Supply Fan: **F** 3000 m³/h Ripresa / Return Fan: **G** m³/h

Corrente / Current: **H** 9.3 A Tensione / Voltage: 230V/1Ph/50-60Hz

MESSA IN FUNZIONE
All'avviamento consultare il manuale operativo e controllare:
1) senso di rotazione del ventilatore
2) l'assorbimento del motore, il quale non deve superare il valore di targa sopraindicato

START UP
Before the start up read carefully the operating instruction manual and check:
1) fan rotation direction
2) the current input must not exceed the value mentioned on the above tag

A DAIKIN APPLIED EUROPE S.p.A
Via Piani di Santa Maria, 72 00040 Ariccia - (ROMA) IT
MADE IN ITALY

- A:** Manufacturer's name and data
- B:** CE markings
- C:** Unit weight
- D:** Code and POS
- E:** Date of manufacture
- F:** Supply airflow rate
- G:** Return airflow rate
- H:** Electrical specifications (frequency, number of phases, absorption in plate conditions)
- I:** Unit serial number

MANUFACTURER INFORMATION:

DAIKIN APPLIED EUROPE S.P.A.

Via Piani di Santa Maria, 72 - 00040 Ariccia (Roma) - Italy

Tel: (+39) 06 93 73 11 - Fax: (+39) 06 93 74 014

<http://www.daikinapplied.eu>

Product nomenclature

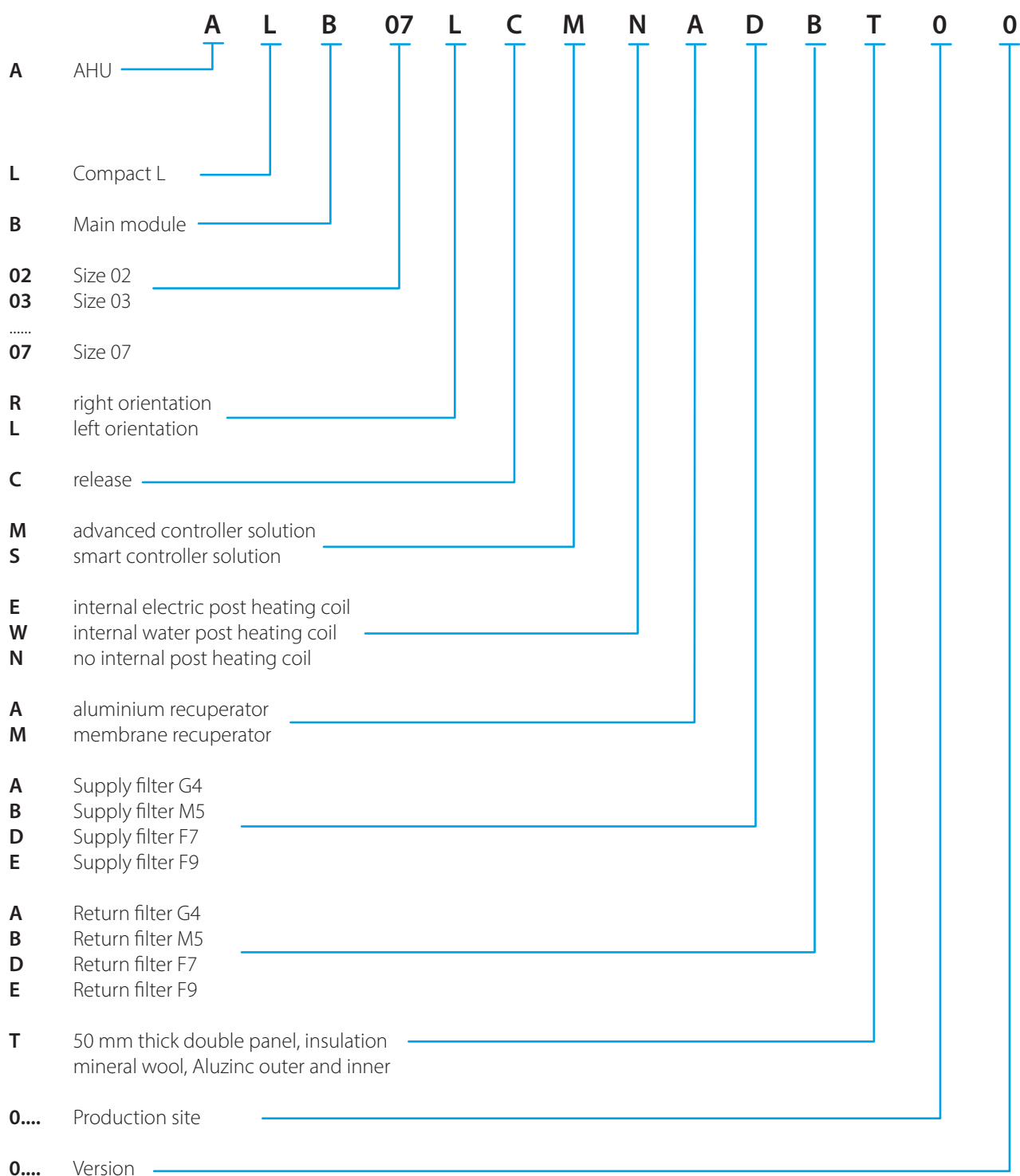

Compact L will be produced according to customer needs. However, we still designed a standard version indicated by only 7 digits AL02 (L)C that uniquely identifies a right/left unit, aluminium counter-current exchanger, double 50mm panel, with Microtech controller, no internal post heating coil, F7 at supply, M5 at return, version 0.

Storage waiting for installation

Waiting for the installation, the components of the unit and the relative documents must be stored in an area that:



If you cannot proceed with the installation straight away, check periodically that the above-mentioned conditions of the storage area are maintained and cover the unit with a canvas.



While waiting for the finale installation, always provide an insulating base (e.g., wood blocks) between the floor and the unit itself.

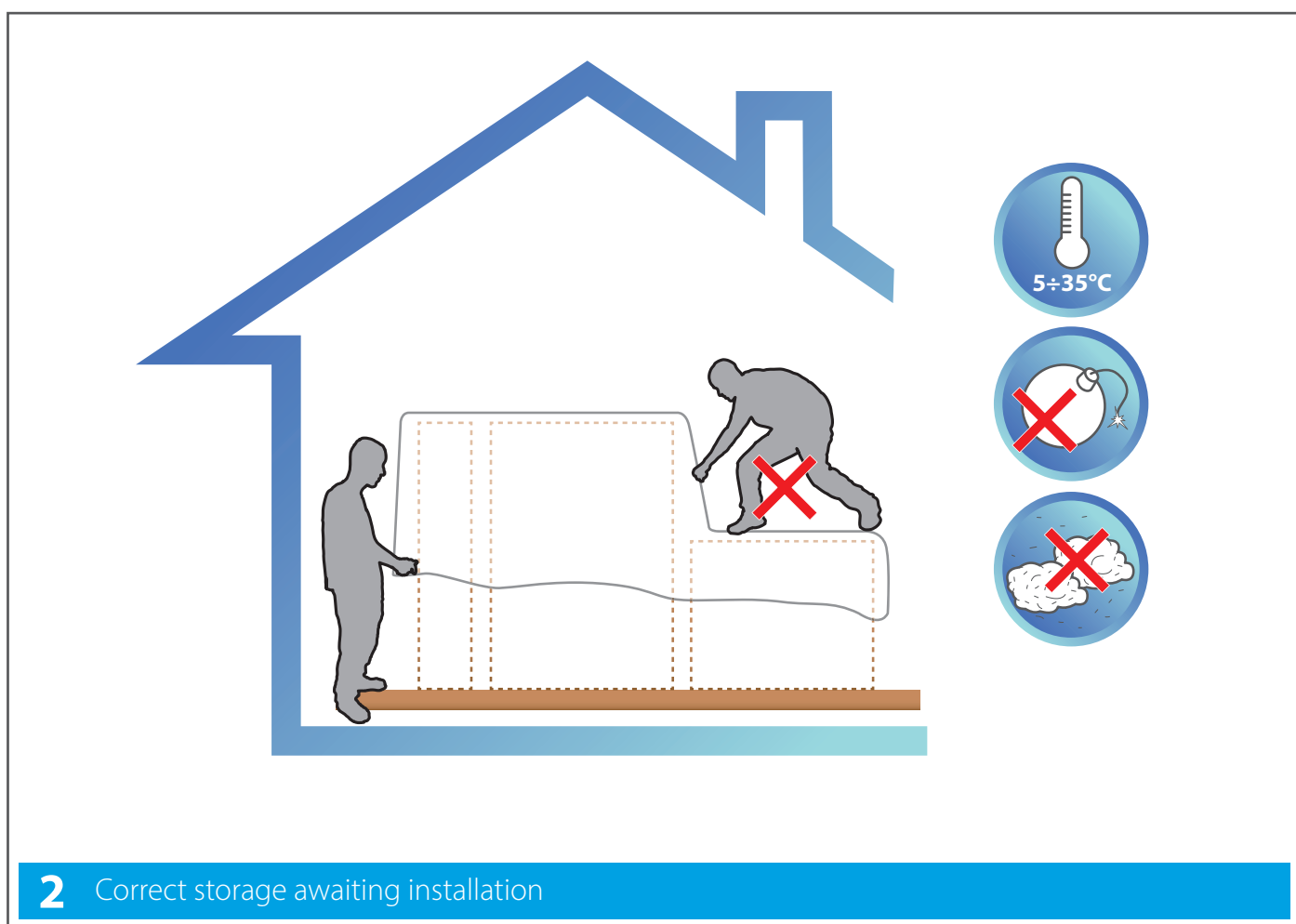

Any movement carried out after unpacking must be done with the doors closed. Do not move the units by pulling on the doors, if present, the uprights or other protruding parts that are not an integral part of the structure.



Do not step on the units!

6 Installation



All installation, assembly, electrical connections to the mains and extraordinary maintenance must be performed **only by qualified personnel authorised by the Retailer or Manufacturer**, in compliance with the regulations in force in the country the equipment is to be used and the standards on the systems and safety in the workplace.



During installation, the area must be free from people and objects not used for the assembly.



Before starting, make sure you have all the necessary equipment.
Use only equipment that is in good condition and undamaged.



Installation procedure

Before installation, read the safety instructions on the first pages of this manual. Contact the Manufacturer if any points are unclear or not perfectly understandable. A check mark next to each step will help to confirm complete and proper installation.

<input type="checkbox"/>	Step 1: Make the holes	page 21
<input type="checkbox"/>	Step 2A: Make the connections for COMPACT L PRO	page 23
<input type="checkbox"/>	Step 2A: Make the connections for COMPACT L PROSMART	page 25
<input type="checkbox"/>	Step 2A: Make the connections for COMPACT L PROAeraulic connection	page 27
<input type="checkbox"/>	Step 4: Perform a trial run	page 28
<input type="checkbox"/>	Step 5: Safety signs.....	page 31

After installation store this manual and the assembly sheet that accompanied the unit in a place that is dry and clean. This way it will be accessible to operators in the future who need to consult it. Do not remove, tear out or write on any part of this manual besides the space set aside for notes:

Step 0: Lift the unit to the ceiling

Lift the unit up to the ceiling.



To facilitate the operations of lifting and to ensure the safety of the installers, we recommend the use of extensible pantograph lifts of the appropriate type and dimensions for the weight and size of the unit to be installed.

During lifting protective apparel must be worn to prevent injury, and individuals not assigned to installation or maintenance are NOT allowed to stand or pass through the work area.

Step 1: Make the holes

Make sure that the **ceiling** where you plan to install the unit is:

- vibration resistant;
- able to **support the weight of the equipment** (see table of technical data on page 12).

The installation site must also include (fig. 3):

- a **water connection** (in the case of connection to coils supplied by water).
- an **electrical system** compliant with current regulations and with specifications that meet the needs of the unit;
- a **coolant gas connection** (in the case of connection to coils supplied by gas).
- a drain pipe with **drain siphon** connected to the sewerage system.
- an **aeraulic system** (ducts for the air to be conveyed to the environments).

Drill $\varnothing 14$ mm holes at the unit anchor points **A** (see the table "Technical data" to page 13).

Insert the appropriate anchors, lift the unit and fasten it using only the brackets and screws supplied.

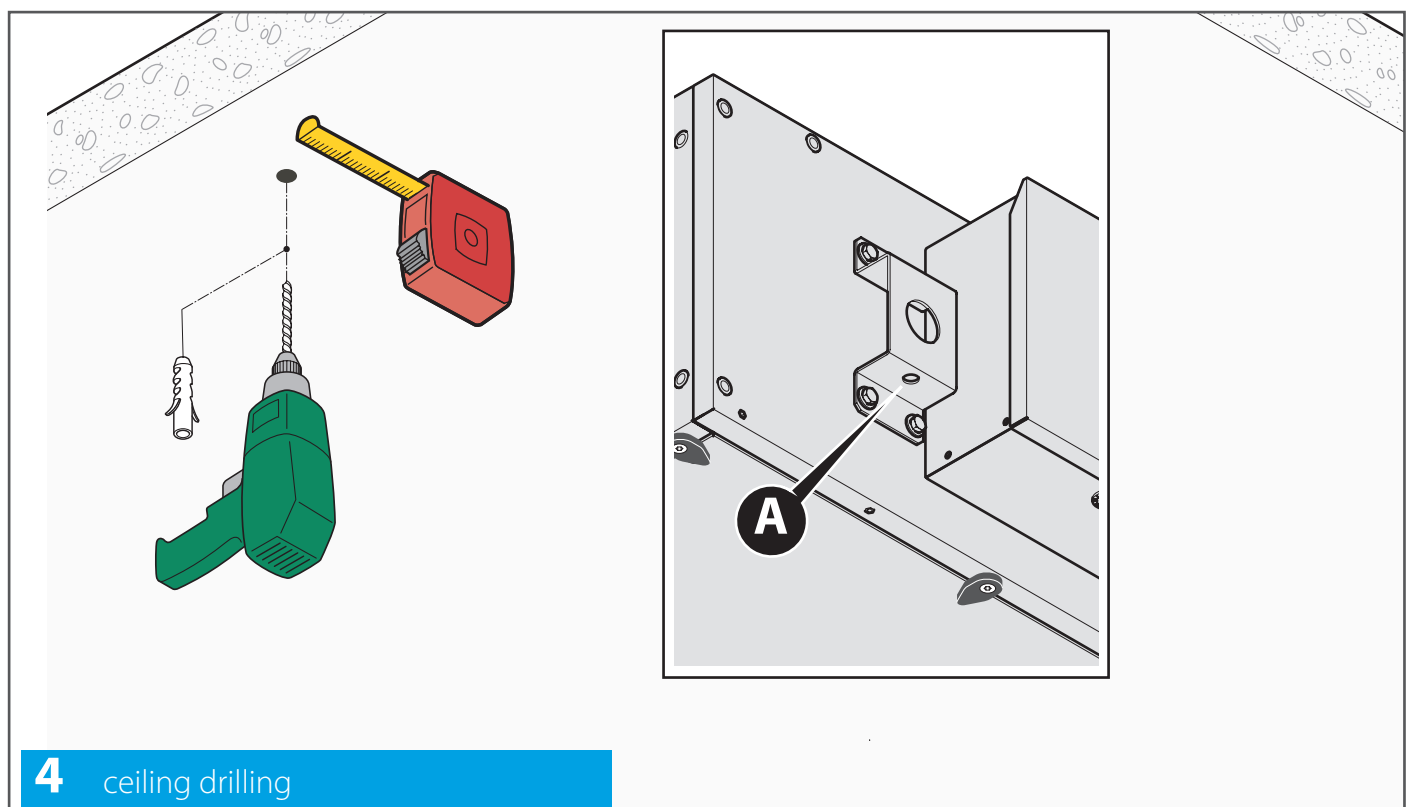
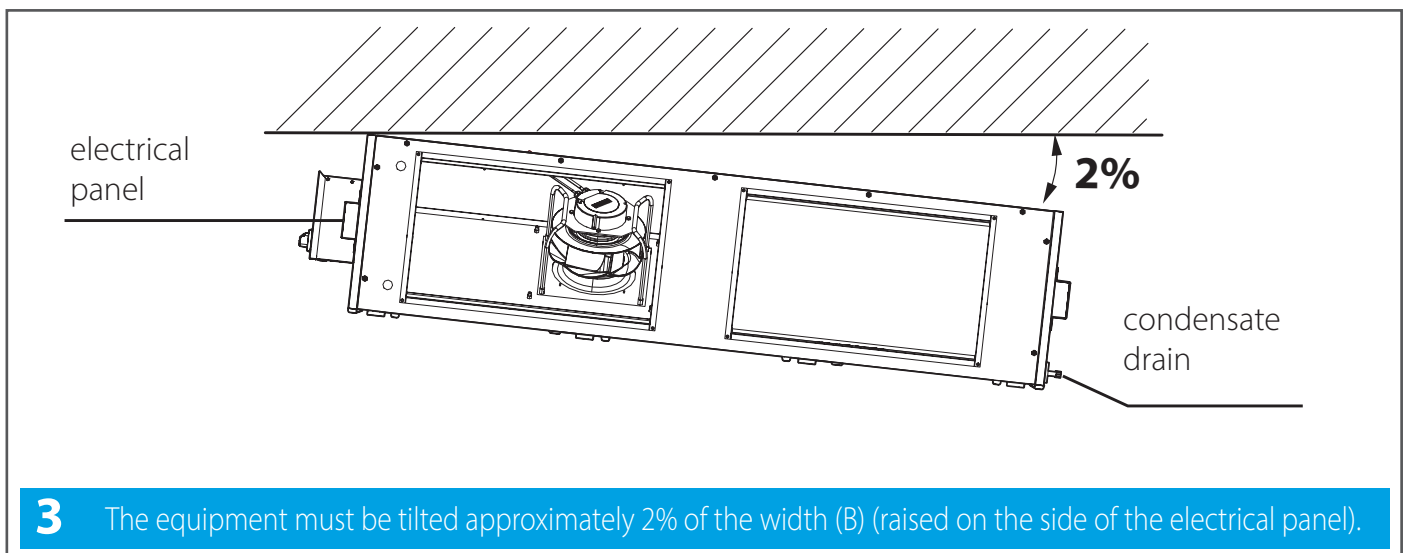

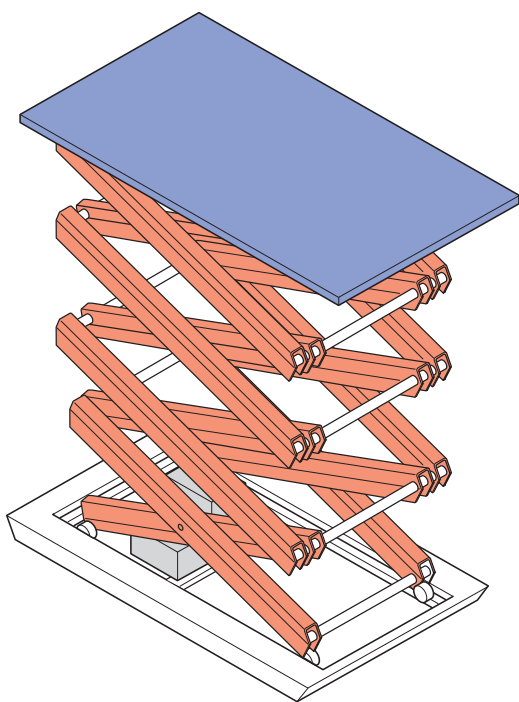
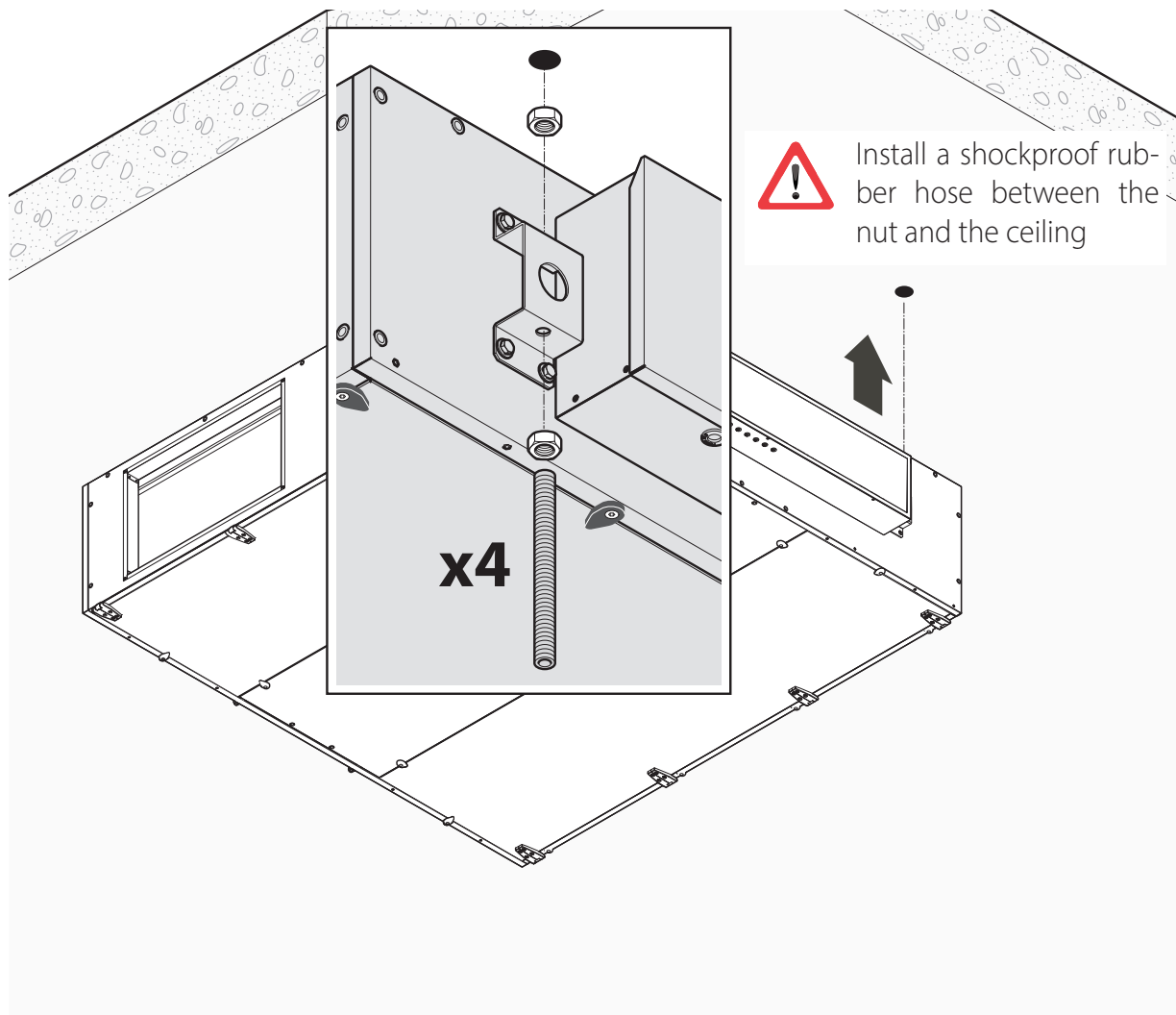

 While lifting and fastening the unit it is **mandatory** to use protective clothing and suitable equipment, in order to prevent accidents and safeguard your own and other people's safety.

The fastening equipment should be dimensioned according to unit weight.

Individuals not assigned to the installation are NOT allowed to stand or pass through the work area during assembly.

 To facilitate the operations of lifting and to ensure the safety of the installers, we recommend the use of extensible pantograph lifts of the appropriate type and dimensions for the weight and size of the unit to be installed.

5 ceiling drilling

Step 2A: Make the connections for **COMPACT L PRO**

To operate the unit requires:

- An electrical connection.
- Drain.
- A connection to the aeraulic circuit (air ducts).

Electrical connection

For the **power supply** it is necessary to connect the unit to an electrical panel in compliance with current regulations.



Always refer to the wiring diagram that is specific to the unit that you bought (it was shipped with the unit). If it is not on the unit or has been lost, contact the salesperson of reference who will send a copy (specify the unit's serial number).

Before connecting the electrical panel, make sure that:

- The voltage and frequency of the power supply correspond to the parameters of the unit.
- The electrical system being connected has sufficient capacity to supply the nominal electric power of the unit to be installed and meets current regulations.



The electrical connection must be:

- Performed by qualified personnel after cutting off the facility's power supply.
- Performed in a fixed and permanent manner, without intermediate splices, in accordance with the regulations of the country of installation.
- The power supply is sufficient for the unit (see technical specifications).
- supplied with an effective, compliant earth connection; where there are multiple units, each unit must be connected to the earth or they must be joined using metal clamps;
- Preferably situated in a dedicated room, **locked** and protected from atmospheric agents. If there is also a key switch, the key must be removed when cutting the power supply and returned to its position only after finishing service operations.
- install a **16A circuit breaker** system or a system suited to the unit absorption



During installation and maintenance, make sure that **no other person** besides the one who is working has access to the electrical cabinets or switches.

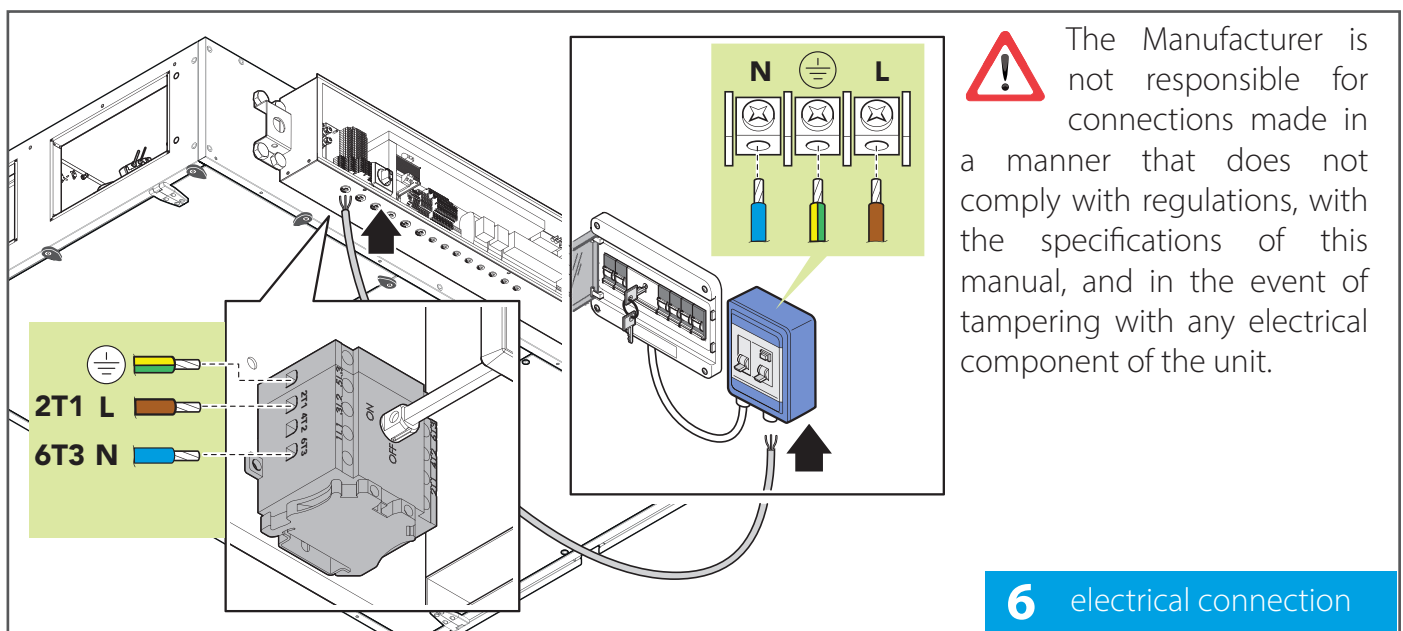



The actual supply voltage of the users **must not deviate more than 10%** from the normal voltage expected. Higher voltage differences cause damage to users and to the electrical system, malfunctioning of fans, noise. It is therefore essential to check the alignment of the actual voltage values with the nominal values.

After connecting, make sure that:

- The ground connection is sufficient (using the appropriate tool). An incorrect connection, ineffective and lacking the grounding circuit, is contrary to safety regulations and is a source of danger and can damage the components of the unit.
- the connections are correct and the current consumption of the motor is lower than indicated on the nameplate.

Ambient thermostat connection

A room thermostat is supplied with the unit, which must be connected as shown in the figure

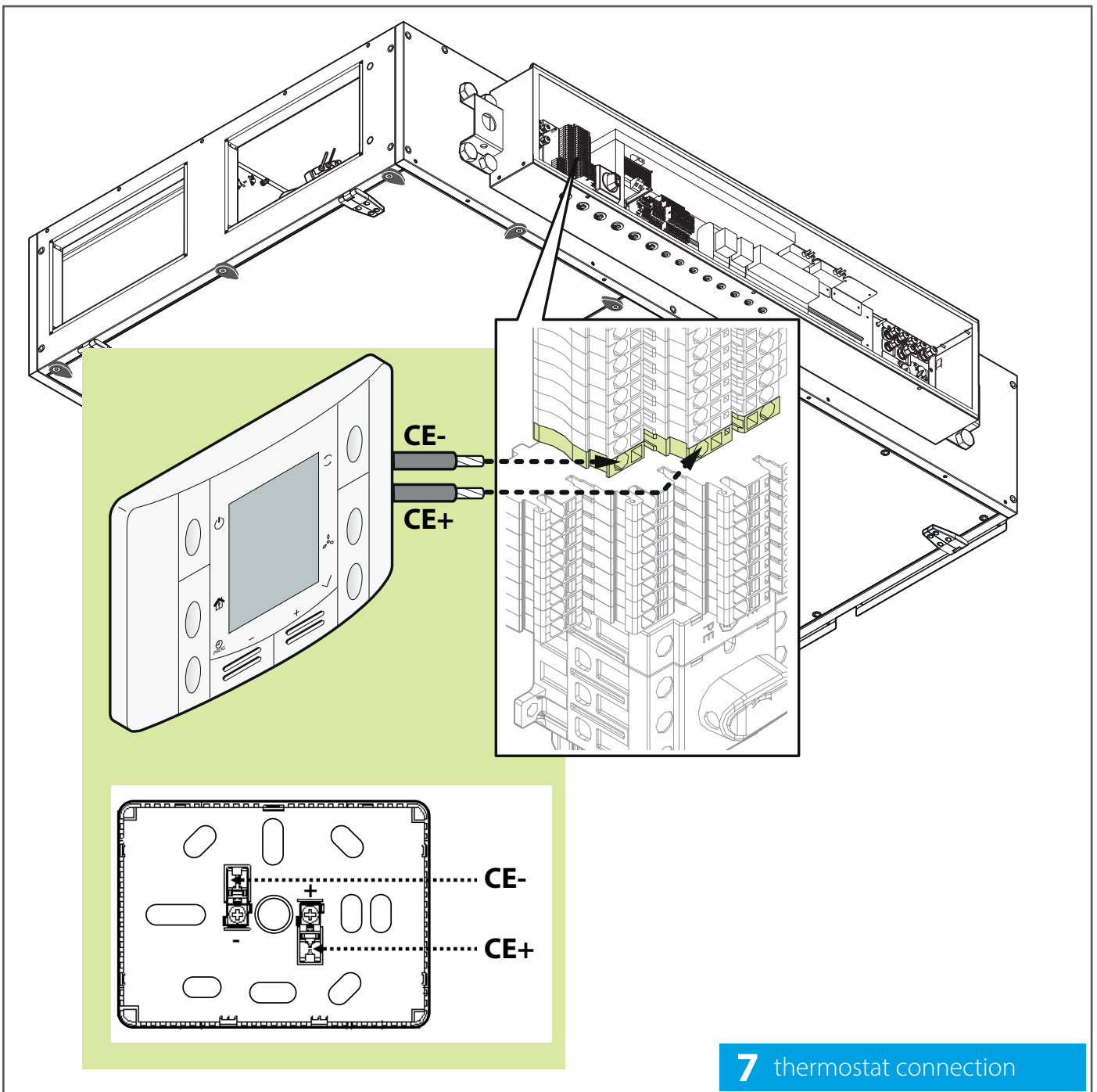

Step 2B: Make the connections for **COMPACT L SMART**

To operate the machine requires:

- An electrical connection.
- Drain.
- A connection to the aeraulic circuit (air ducts).

Electrical connections

For the **power supply** it is necessary to connect the machine to an electrical panel in compliance with current regulations.



Always refer to the wiring diagram that is specific to the machine that you bought (it was shipped with the unit). If it is not on the machine or has been lost, contact the salesperson of reference who will send a copy (specify the machine's serial number).

Before connecting the machine make sure that:

- The voltage and frequency of the power supply correspond to the parameters of the machine.
- The electrical system being connected has sufficient capacity to supply the nominal electric power of the machine to be installed and meets current regulations.



The electrical connection must be:

- Performed by qualified personnel after cutting off the facility's power supply.
- Performed in a fixed and permanent manner, without intermediate splices, in accordance with the regulations of the country of installation.
- The power supply is sufficient for the machine (see technical specifications).
- supplied with an effective, compliant earth connection; where there are multiple units, each unit must be connected to the earth or they must be joined using metal clamps;
- Preferably situated in a dedicated room, **locked** and protected from atmospheric agents. If there is also a key switch, the key must be removed when cutting the power supply and returned to its position only after finishing service operations.
- install a **16A circuit breaker system** or suited to machine absorption



During installation and maintenance, make sure that **no other person** besides the one who is working has access to the electrical cabinets or switches.

⚠ The Manufacturer is not responsible for connections made in a manner that does not comply with regulations, with the specifications of this manual, and in the event of tampering with any electrical component of the machine.

8 electrical connection



The actual supply voltage of the users **must not deviate more than 10%** from the normal voltage expected. Higher voltage differences cause damage to users and to the electrical system, malfunctioning of fans, noise. It is therefore essential to check the alignment of the actual voltage values with the nominal values.

After connecting, make sure that:

- The ground connection is sufficient (using the appropriate tool). An incorrect connection, ineffective and lacking the grounding circuit, is contrary to safety regulations and is a source of danger and can damage the components of the machine.
- the motor rotation direction is correct;
- The wiring and motor power draw are correct.

BRC controller connection

For the Compact L Smart start up connect the BRC controller (purchasable separately) to the terminals P1 and P2 as shown in the picture below.

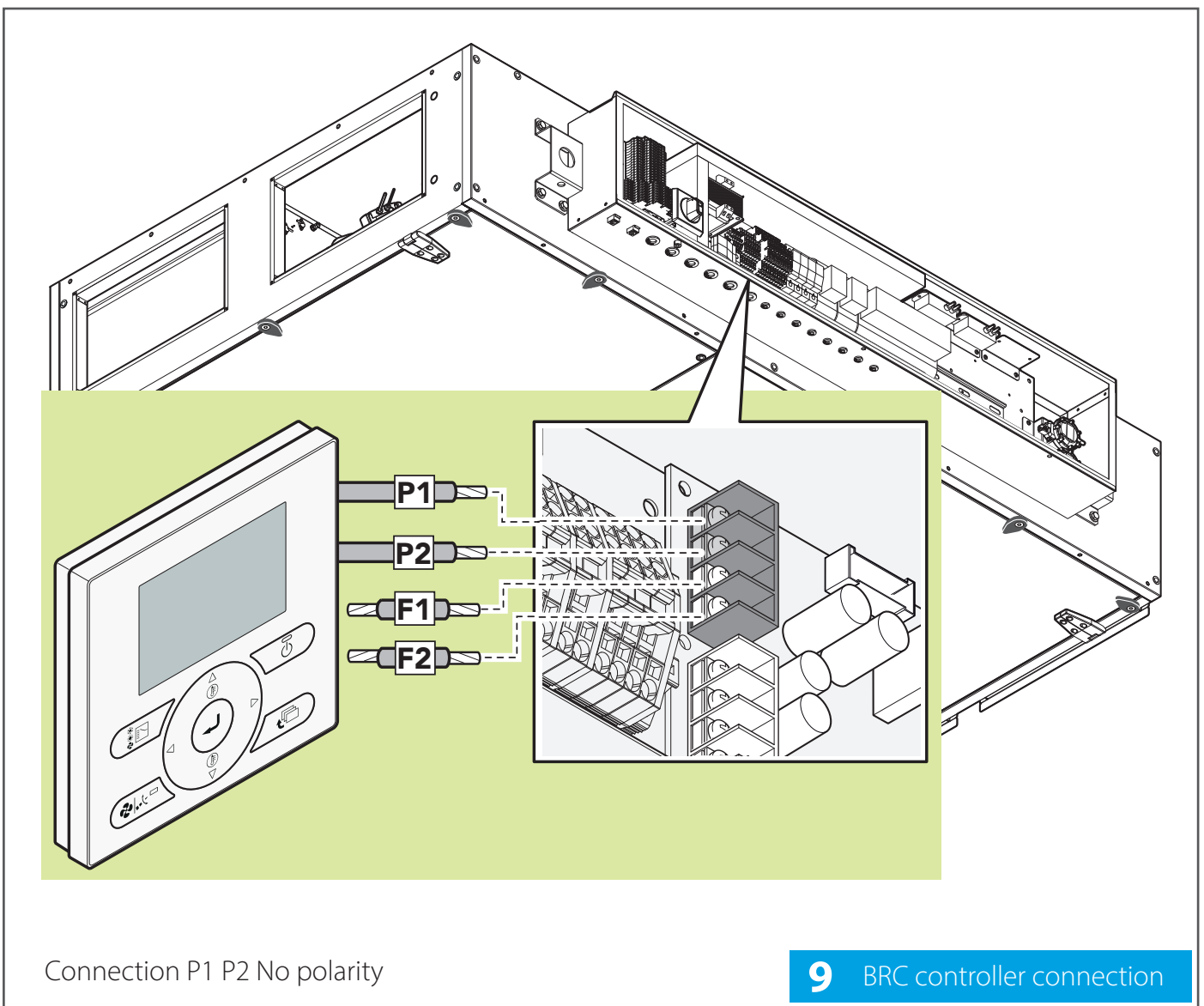

Step 3: Aeraulic connection

drain and siphon

The units are equipped with a threaded drain (1/4" M GAS) that **protrudes laterally by about 50 mm**. In order to allow a regular flow of water, each drain must be fitted with a properly sized SIPHON (see fig. 11).

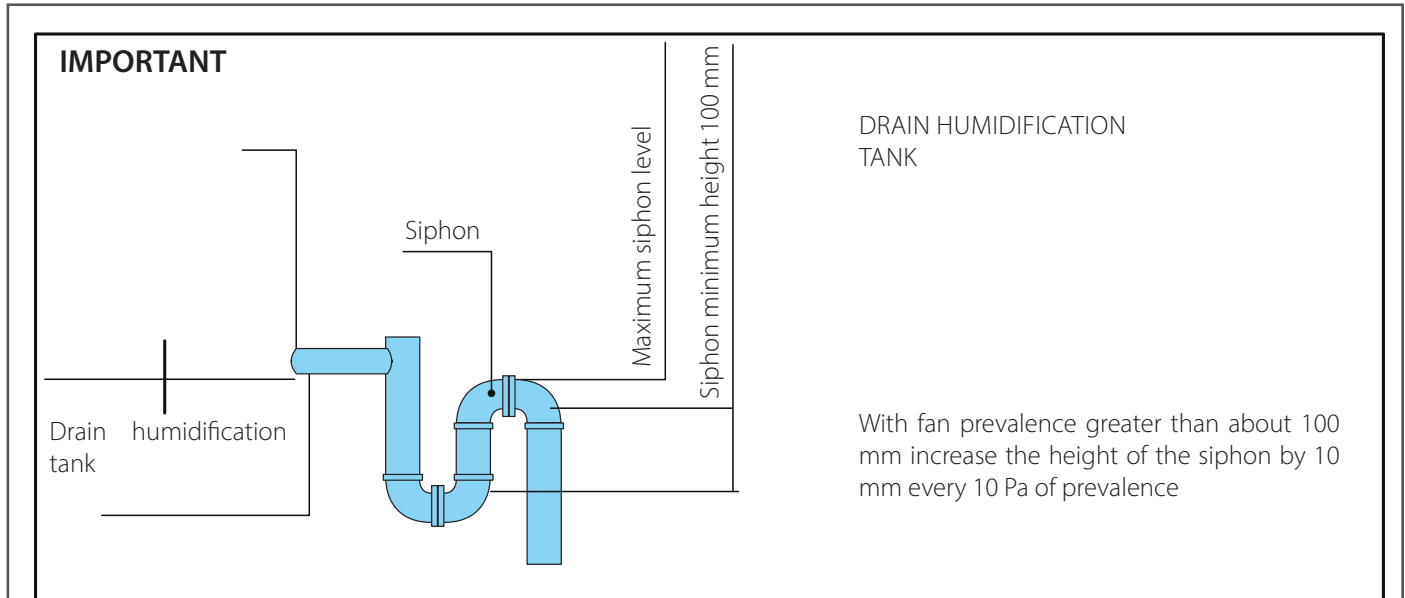

10 Drain siphon

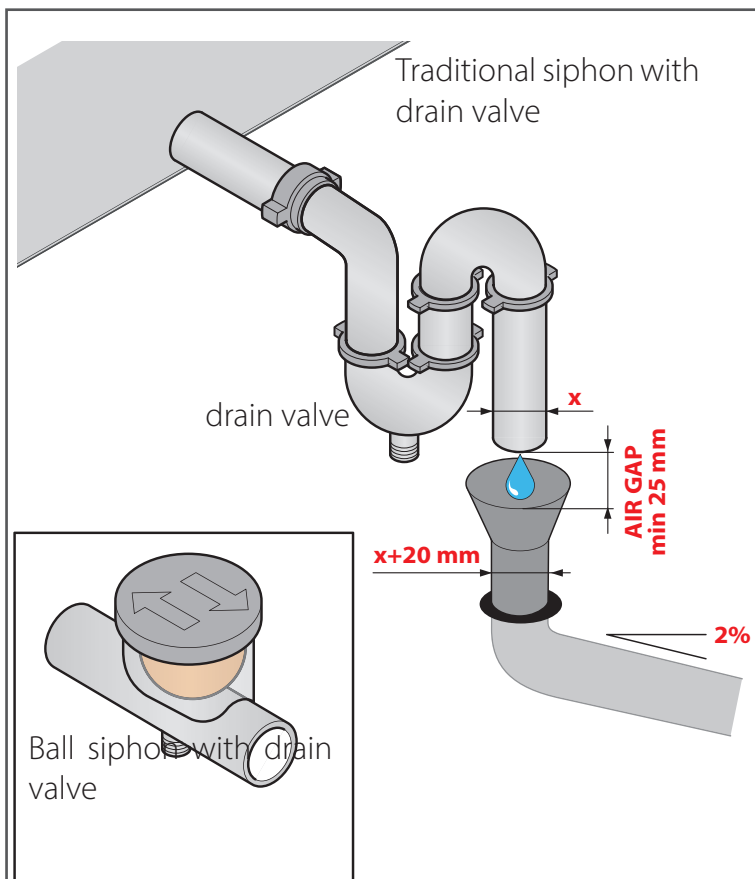

To avoid overflows from the collection tank, the siphon must have a **purge valve** that allows the removal of impurities deposited on the bottom.

In order not to affect the operation of the drainage system, siphons operating under pressure must NOT be connected to others operating under vacuum.

The drainage pipe to the sewerage network:

- **Must not be connected directly to the siphon.** This in order to absorb returns of air or slurry and to make the correct outflow of waste water visible.
- Must have a larger diameter at the unit drain and a minimum inclination of 2% in order to ensure proper operation.

11 traditional and ball drain siphon

Aeraulic connections

Air conduits are not supplied with the unit. The installer must buy and install them separately. Coupling can occur by directly connecting the unit: we recommend installing a suitable shock absorption system between the unit and conduit.

If not using anti-vibration joints it is necessary to:

- Clean the joint surfaces between the duct and the unit/coil.
- Apply a gasket to the flange in order to prevent air infiltration.
- Carefully tighten the connecting screws.
- Use silicone on the gasket in order to optimise the seal.

If the connection is made with anti-vibration joints, when assembly is completed they should not be taut, so as to avoid damage and the transmission of vibrations.

In order to ensure the seal of the connection and the integrity of the unit's structure, it is essential to make sure that the ducts do not weigh on it, being supported by their own brackets.

Step 4: Perform a trial run

To commission the unit it is necessary (tick "✓" the operations completed):

	Check accurate fluid inlet and output pipe connections to the exchange coils (if applicable)
	Check that there is a suitable siphon for all the water being drained.
	Place a shock absorbing joint between the unit and conduits (optional);
	Check unit integrity;
	Check the integrity of the anti-vibration supports and the various accessories.
	Remove extraneous materials (e.g., assembly sheets, tools, clips, etc.) and dirt (footprints, dust, etc.) from inside the sections.

Connection of the internal hot water coil for ALB**LCMW

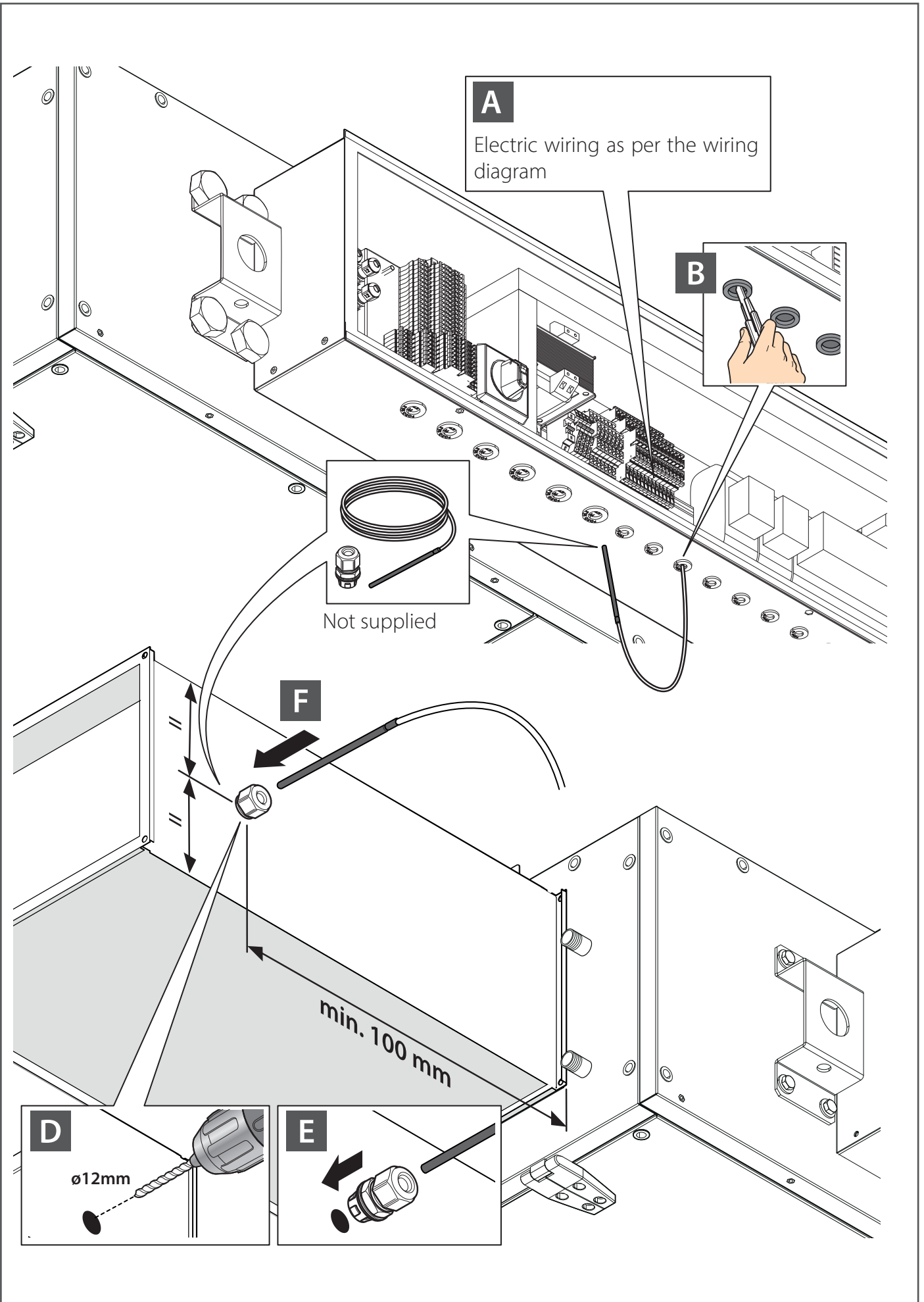

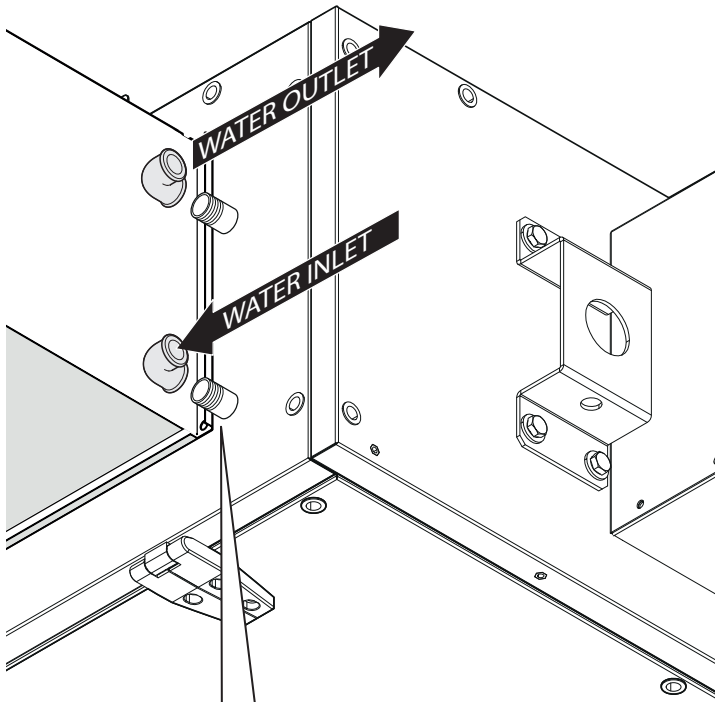

Electric wiring as per the wiring diagram

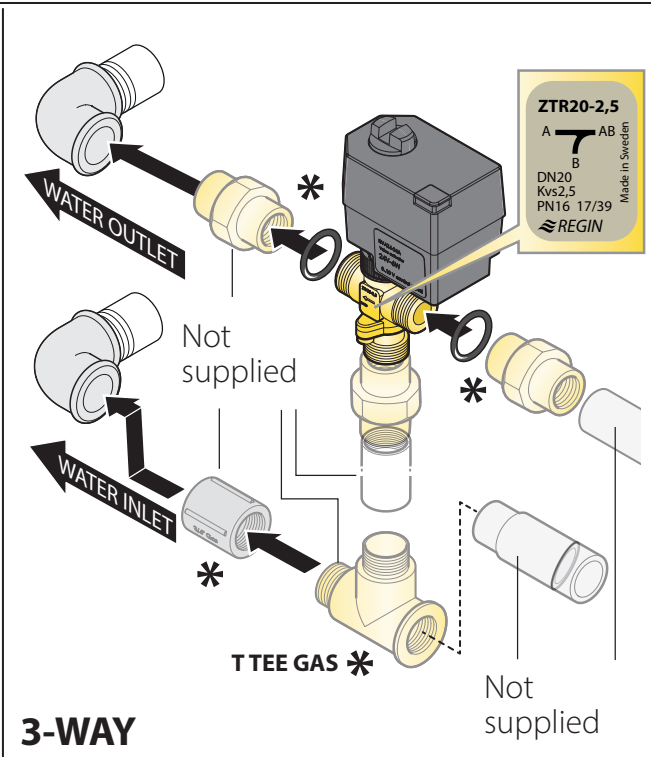
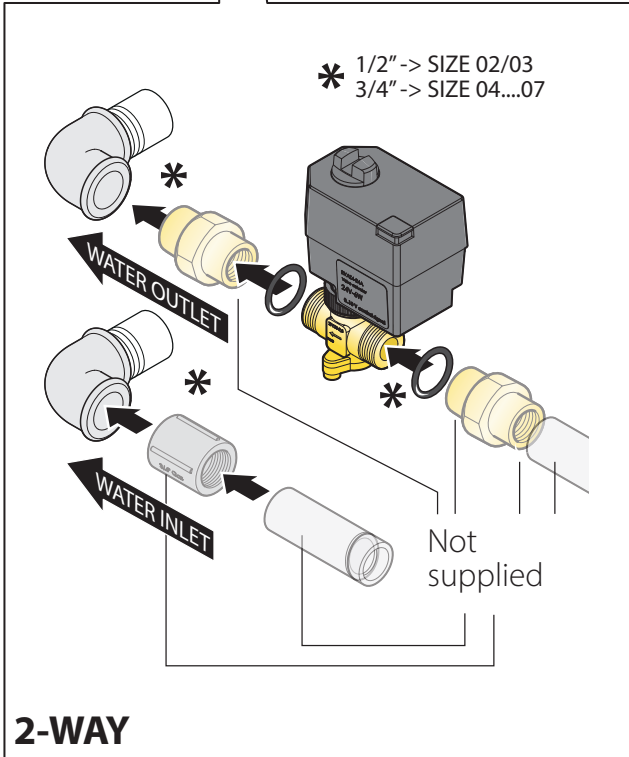
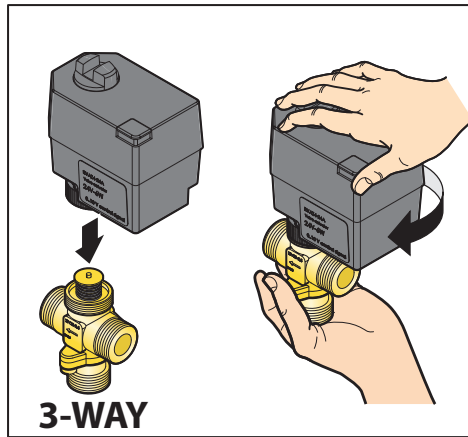
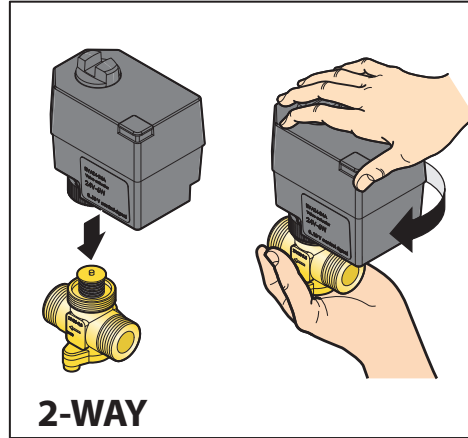

Step 5: Safety signs

The unit is supplied with the electricity-specific signs on the access doors to the fan sections.

The buyer must position other appropriate signs in the work area:

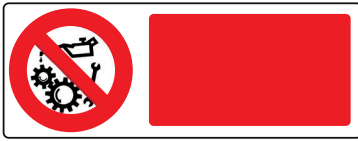

DO NOT REMOVE THE PROTECTIONS AND SAFETY DEVICES



DO NOT REPAIR - OIL - ADJUST - CLEAN MOVING PARTS

In addition, the space where the unit is positioned must be integrated into the general signage, specific to the characteristics of the area and workplaces:

noise - movement - dangerous areas - escape route, etc.

PERSONAL PROTECTIVE EQUIPMENT

Personal protective equipment should be used when operating the unit, suitable for use in accordance with company criteria and rules.

During unit maintenance, other preventive measures are suggested in addition to the above: safety shoes, gloves, suitable clothing, always compatible with the use and according to company guidelines.

TRAINING

It is the responsibility of the unit buyer/user to provide adequate instruction and training to unit operators.

OPTIONAL

In agreed cases, additional training may be provided through the one-on-one instruction of operators by the Manufacturer's technical staff.

7 Commissioning

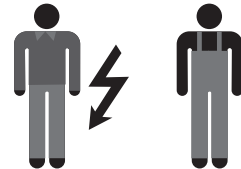

For **PRO version** please to refer to OM.

For **SMART version** to follow this procedure:

Configuration

The settings (format: XX(XX)-X-XX), for example 19(29)-1-02, that are used in this chapter are composed of 3 parts, divided by "-":

- Mode number: for example, 19(29), where 19 is the mode number for group settings and 29 is the mode number for individual settings
- Switch number: for example, 1
- Position number: for example, 02

Operating procedure

You can use either the user interface of the Compact L Smart or of the air conditioner to adjust the heat reclaim ventilation unit settings.

Initial settings

- Mode numbers 17, 18, and 19: group control of Compact L Smart.
- Mode numbers 27, 28, and 29: individual control

To change the settings with BRC1E53

Make sure that the switch box lids on the Compact L Smart are closed.

1. Shortly press a button to turn on the screen light.
2. Press and hold the Cancel button (a) for at least 4 seconds to enter the Service Settings menu.
3. Go to Field Settings with the Up/Down buttons and press the Menu/Enter button (b).
4. Press the Left/Right buttons to highlight the number under Mode.
5. Press the Up/Down buttons to select the required mode number.
Result: Depending on the mode number that you select, starting at 20, you will also have to select a unit number, for the individual control.
6. Use the Left/Right buttons to highlight the number under Unit No.
7. Use the Up/Down buttons to select an indoor unit number. Selecting a unit number is NOT necessary when you are configuring the entire group.
8. Use the Left/Right buttons to select a position number (0 to 15) for the switch number that you want to change.

In case of individual settings:

Field Settings			
Unit No.	Mode		
0	20		
0-01	1-00	2-00	3-00
4—	5—	6—	7—
8—	9—	10—	11—
12—	13—	14—	15—
Return	Setting	↔	

In case of group settings:

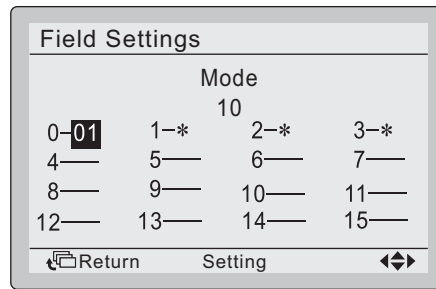

9. Use the Up/Down buttons to select the required position.
10. Press the Menu/Enter (b) button and confirm the selection with Yes.

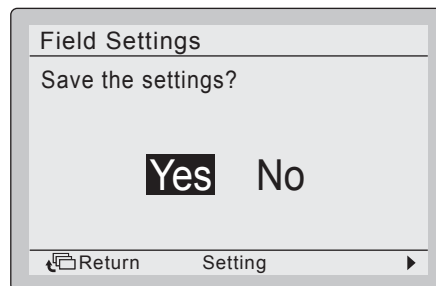

11. After you have completed all the changes, press the Cancel button (a) twice to return to the normal mode.

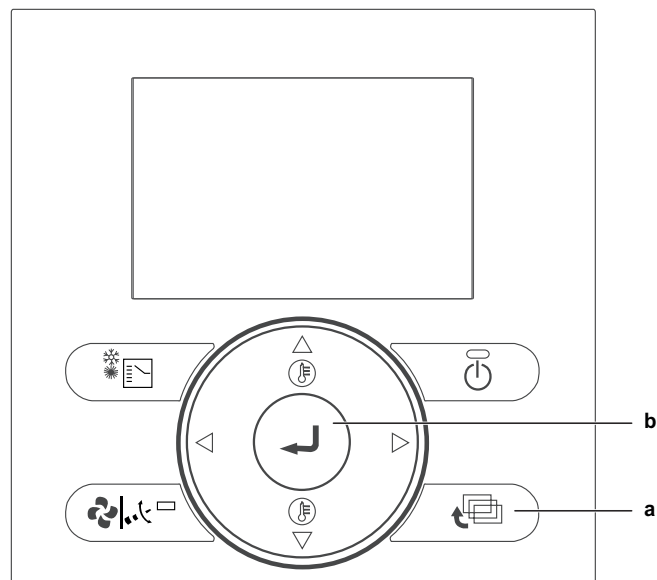

List of the settings

Setting mode	Setting switch no.	Setting description	Setting position no.					Setting position no.										
			01	02	03	04	05	06	07	08	09	10	11	12	13	14	15	
19(29)	0	Filter contamination inspection setting	Filter contamination check with fan step 1-15	Filter contamination check with new fan step	Timer based check	Target detection filter with fan step 1-15	Auto ESP selection + target detection filter with new fan step											
	1	Low tap setting	Off	Run 1/15 (28 min. off/2 min. on)	Run 1/10 (27min. Off/3 min. on)	Run 1/6 (25min. Off/5 min. on)	Run 1/4 (22.5min. Off/7.5 min.on)	Run 1/3 (20min. Off/10 min.on)	Run 1/2 (15min. Off/15 min.on)	Continuous operation								
	2	Supply fan step setting*	Step 1	Step 2	Step 3	Step 4	Step 5	Step 6	Step 7	Step 8	Step 9	Step 10	Step 11	Step 12	Step 13	Step 14	Step 15	
	3	Exhaust fan step setting*	Step 1	Step 2	Step 3	Step 4	Step 5	Step 6	Step 7	Step 8	Step 9	Step 10	Step 11	Step 12	Step 13	Step 14	Step 15	
	4	24 hour ventilation setting	Off	Run 1/15 (28 min. off/2 min. on)	Run 1/10 (27min. Off/3 min. on)	Run 1/6 (25min. Off/5 min. on)	Run 1/4 (22.5min. Off/7.5 min.on)	Run 1/3 (20min. Off/10 min.on)	Run 1/2 (15min. Off/15 min.on)	Continuous operation								
	7	Reference concentration shift for ventilation flow control (ppm)	0	+200	+400	+600	-200	-400	-600									
	8	Stop ventilation by automatic ventilation air flow control	Allowed	NOT Allowed	Allowed	NOT Allowed												
		Fan residual operation	Off	Off	Heater operation	Heater operation												
	9	Normal ventilation tap on automatic ventilation air flow control					Control by CO ₂ sensor											
1A	0	Fresh-up operation**	Off	On														

Setting mode	Setting switch no.	Setting description	Setting position no.					Setting position no.										
			01	02	03	04	05	06	07	08	09	10	11	12	13	14	15	
17(27)	0	Filter cleaning time setting	Approx. 2500 hours	±1250 hours														
	1	Nigh-time free cooling timer (after stop)	Off	On after 2 hours	On after 4 hours	On after 6 hours	On after 8 hours											
	2	Pree-cool/pre-heat	Off	On														
	3	Pre-cool/pre-heat duration	30 minutes	45 minutes	60 minutes													
	4	Initial fan speed	High	Ultra-high														
	5	Yes/No setting for duct connection with VRV system	Without duct	With duct	Without duct	With duct												
		Setting for cold areas (fan operation when heater thermostat is off)			Stop	Low	Stop	Low										
	6	Nigh-time free cooling (fan settings)	High	Ultra-high														
	7	Target temperature for independent Nigh-time free cooling	18°C	19°C	20°C	21°C	22°C	23°C	24°C	25°C	26°C	27°C	28°C	29°C	30°C			
	8	Centralised zone interlock setting	No	Yes														
9	Pre-heat time extension setting	0 minutes	30 minutes	60 minutes	90 minutes													

Setting mode	Setting switch no.	Setting description	Setting position no.					Setting position no.												
			01	02	03	04	05	06	07	08	09	10	11	12	13	14	15			
18(28)	0	External signal JC/J2	Last command	Priority on external input	Priority on operation	Disable night-time free cooling / Forced stop		24 hours ventilation On/Off												
	1	Setting for direct Power	Off	On																
	2	Autorestart setting	Off	On																
	3	Output signal to external damper (X24A)			Damper output (fan operation)	Damper output (fan operation)														
	4	Indication of ventilation mode	On	Off																
	6	Automatic ventilation air flow mode	Linear		Fixed A	Fixed B														
	7	Fresh-up mode	No indication supply	No indication supply	Indication exhaust	Indication exhaust														
	8	External input terminal function selection (between J1 and JC)	Fresh-up	Error output	Error output stop operation	Forced off	Fan forced off	Air-flow up												
	9	BRP4A50A output switching selection (between X3 and X4)	Heater output	Error output	Fan output (Low/High/Ultra-high)	Fan output (High/Ultra-high)	Fan output (Ultra-high)	Fan output (Low/High/Ultra-high)												
	11	Filter contamination check**	No action	Reset filter check	Force filter check															

How to select the optimal Ventilation Speed

The fine tuning of the Ventilation Speed can be done properly modifying the following parameters:

- Initial fan speed: High or Ultra-High
- Supply fan step setting: Step 1 to 15
- Exhaust fan step setting: Step 1 to 15

These parameters can be accessed following the procedure "The Configuration **Service Settings** → **Field Settings** page, as shown in the List of Settings paragraph.

Both Supply and Return Fans have an optimal speed value, described in term of **RPM** (Revolution per Minute), that can be retrieved directly from the DAE Unit Selection Software report, as shown below:

3) Fan Supply

Model	VBH0190SSLES
Type	EC
Material	Composite
Quantity	1x(Single Fan)
External Static Pressure	100 Pa
Internal Static Pressure	177 Pa
Total Static Pressure	277 Pa
Dynamic Pressure	6 Pa
Flow Design	300 m ³ /h
Rotation Speed Work • Max	2906 RPM • 4350 RPM
Efficiency	47.8%
Electrical Power Input	0.06 kW
Power Class • PMREF (EN13053)	P1 • 0.13 kW
SFPv Class • SFPv (EN13053)	SFP1 • 580 W/(m ³ /s)

3) Fan Return

Model	VBH0190SSLES
Type	EC
Material	Composite
Quantity	1x(Single Fan)
External Static Pressure	100 Pa
Internal Static Pressure	138 Pa
Total Static Pressure	238 Pa
Dynamic Pressure	6 Pa
Flow Design	300 m ³ /h
Rotation Speed Work • Max	2747 RPM • 4350 RPM
Efficiency	48.4%
Electrical Power Input	0.05 kW
Power Class • PMREF (EN13053)	P1 • 0.12 kW
SFPv Class • SFPv (EN13053)	SFP1 • 492 W/(m ³ /s)

Optimal RPM values for Supply and Return(Exhaust) Fans

Provided the Unit Size is known, you can proceed to set the correspondent Supply/Return Fan step on the BRC controller, according to the following Speed-selection Tables (Make sure to consider "Heat recovery operation" rpm).

If you do not have the unit selection from Daikin tool software, please check individual unit size performances from page 36 onwards.

Speed-selection tables

In order to select the correct step for the Supply and Return Fan it is necessary to:

- Choose the table whose Unit Size number equals the Unit Size provided in the DAE Unit Selection software report.
- Identify the Supply/Return Fan steps by choosing, from H(high) column, the steps whose RPM values are the closest to the Supply/Return Fan RPM provided by DAE Unit Selection software report.
- Set the selected step values on the controller by going to the path **Service Settings → Field Settings** and set the following
 - a. **19(29)-2- Selected_Step_Supply_Fan**, for the Supply Fan Step, from 01 to 15
 - b. **19(29)-3- Selected_Step_Return_Fan**, for the Return Fan Step, from 01 to 15
- If both Supply and Return Fan RPM are not present in the column H, but they appear in UH(ultra high) one, then:
 - Set the Initial Fan Speed to UltraHigh by going to the path **Service Settings → Field Settings** and modifying the default value from **17(27)-4-01(High)** to **17(27)-4-02(UltraHigh)**
 - Set the selected steps as in point 3.

Step		ML Smart Size 02											
		Supply fan						Exhaust fan					
		Heat recovery operation			Bypass operation			Heat recovery operation			Bypass operation		
		UH	H	L	UH	H	L	UH	H	L	UH	H	L
SA Fan RPM set- ting (19(29)-2- ...)	1	2779	2315	1221	2907	2347	1320	3068	2614	1647	2753	2264	1221
	2	2860	2399	1316	2983	2450	1404	3132	2690	1727	2826	2334	1294
	3	2940	2490	1412	3060	2545	1492	3199	2773	1809	2903	2410	1367
	4	3017	2574	1509	3137	2629	1572	3262	2846	1892	2973	2481	1440
	5	3094	2658	1608	3215	2725	1657	3329	2922	1978	3043	2557	1513
	6	3170	2731	1704	3295	2808	1744	3392	2982	2058	3113	2627	1587
	7	3247	2808	1803	3372	2903	1829	3460	3050	2140	3180	2703	1660
	8	3320	2882	1894	3449	2987	1913	3523	3110	2223	3250	2770	1736
EA Fan RPM set- ting (19(29)-3- ...)	9	3408	2966	1996	3536	3082	2018	3603	3183	2312	3329	2849	1829
	10	3503	3039	2099	3627	3170	2128	3689	3246	2395	3412	2925	1923
	11	3591	3101	2194	3715	3236	2227	3765	3303	2471	3488	2992	2009
	12	3683	3174	2289	3806	3309	2332	3848	3371	2554	3571	3055	2105
	13	3763	3240	2373	3894	3376	2428	3921	3428	2630	3647	3116	2191
	14	3851	3316	2465	3986	3449	2512	3997	3494	2716	3733	3180	2280
	15	3928	3378	2549	4070	3514	2589	4070	3548	2789	3806	3240	2346

This table refers to indicated values subject to tolerances.

In order to adjust the desired airflow value based on measurement at site, while increasing rpm you will obtain more air flow and while decreasing rpm, you will reduce air flow. If needed, kindly change fan speed to reach the target air flow.

Step		ML Smart Size 03 & Size 04											
		Supply fan						Exhaust fan					
		Heat recovery operation			Bypass operation			Heat recovery operation			Bypass operation		
		UH	H	L	UH	H	L	UH	H	L	UH	H	L
SA Fan RPM setting (19(29)-2-...)	1	2552	2125	1121	2669	2155	1212	2817	2400	1512	2528	2079	1121
	2	2626	2202	1208	2739	2249	1289	2875	2470	1586	2595	2143	1188
	3	2699	2287	1296	2810	2337	1370	2937	2546	1661	2666	2213	1255
	4	2770	2364	1386	2881	2414	1443	2995	2613	1737	2730	2278	1322
	5	2841	2441	1477	2952	2502	1521	3057	2683	1816	2794	2347	1390
	6	2911	2508	1565	3025	2579	1601	3115	2738	1889	2858	2412	1457
	7	2981	2579	1655	3096	2666	1679	3176	2800	1965	2920	2482	1524
	8	3049	2646	1739	3166	2743	1756	3235	2855	2041	2984	2543	1594
EA Fan RPM setting (19(29)-3-...)	9	3129	2723	1833	3246	2830	1853	3308	2922	2122	3057	2616	1679
	10	3216	2790	1927	3331	2911	1954	3387	2981	2199	3133	2686	1766
	11	3297	2847	2015	3411	2971	2044	3457	3033	2269	3203	2747	1845
	12	3381	2914	2102	3495	3039	2142	3533	3095	2345	3279	2805	1933
	13	3455	2975	2179	3576	3099	2230	3600	3147	2415	3349	2861	2012
	14	3536	3045	2263	3660	3166	2307	3670	3208	2493	3428	2920	2093
	15	3606	3102	2340	3737	3226	2377	3737	3258	2561	3495	2975	2154

Step		ML Smart Size 05											
		Supply fan						Exhaust fan					
		Heat recovery operation			Bypass operation			Heat recovery operation			Bypass operation		
		UH	H	L	UH	H	L	UH	H	L	UH	H	L
SA Fan RPM setting (19(29)-2-...)	1	2091	1742	919	2188	1766	993	2309	1967	1239	2072	1704	919
	2	2152	1805	990	2245	1844	1056	2357	2024	1300	2127	1757	974
	3	2212	1874	1062	2303	1915	1123	2407	2087	1361	2185	1814	1029
	4	2270	1937	1136	2361	1978	1183	2455	2142	1424	2238	1867	1084
	5	2328	2001	1210	2419	2050	1247	2505	2199	1488	2290	1924	1139
	6	2386	2056	1282	2479	2114	1312	2553	2244	1549	2343	1977	1194
	7	2444	2114	1357	2537	2185	1376	2604	2295	1610	2393	2034	1249
	8	2499	2169	1425	2595	2248	1439	2651	2340	1673	2446	2085	1306
EA Fan RPM setting (19(29)-3-...)	9	2565	2232	1503	2661	2320	1519	2711	2395	1740	2505	2144	1376
	10	2636	2287	1580	2730	2386	1601	2776	2443	1802	2568	2201	1447
	11	2702	2334	1651	2796	2436	1676	2833	2486	1859	2625	2252	1512
	12	2772	2389	1723	2864	2491	1755	2896	2537	1922	2688	2299	1584
	13	2832	2439	1786	2931	2540	1827	2951	2580	1979	2745	2345	1649
	14	2898	2496	1855	3000	2595	1891	3008	2630	2044	2809	2393	1716
	15	2956	2543	1918	3063	2644	1949	3063	2670	2099	2864	2439	1766

This table refers to indicated values subject to tolerances.

In order to adjust the desired airflow value based on measurement at site, while increasing rpm you will obtain more air flow and while decreasing rpm, you will reduce air flow. If needed, kindly change fan speed to reach the target air flow.

Step		ML Smart Size 06											
		Supply fan						Exhaust fan					
		Heat recovery operation			Bypass operation			Heat recovery operation			Bypass operation		
		UH	H	L	UH	H	L	UH	H	L	UH	H	L
SA Fan RPM setting (19(29)-2-...)	1	2076	1729	912	2172	1753	986	2292	1952	1230	2056	1691	912
	2	2136	1792	983	2228	1830	1049	2339	2009	1290	2111	1744	967
	3	2196	1860	1054	2286	1901	1114	2389	2071	1351	2169	1800	1021
	4	2253	1923	1127	2343	1963	1174	2436	2126	1413	2221	1853	1076
	5	2311	1986	1201	2401	2035	1237	2487	2183	1477	2273	1910	1130
	6	2368	2040	1273	2461	2098	1302	2534	2228	1537	2325	1962	1185
	7	2425	2098	1347	2518	2169	1366	2584	2278	1598	2375	2019	1240
	8	2480	2152	1414	2576	2231	1429	2631	2323	1660	2428	2069	1296
EA Fan RPM setting (19(29)-3-...)	9	2546	2215	1491	2641	2302	1507	2691	2377	1727	2487	2128	1366
	10	2616	2270	1568	2709	2368	1589	2755	2425	1789	2549	2185	1437
	11	2682	2316	1639	2775	2417	1663	2812	2467	1845	2605	2235	1501
	12	2751	2371	1710	2843	2472	1742	2874	2518	1907	2667	2282	1572
	13	2811	2420	1772	2909	2521	1814	2929	2560	1964	2724	2327	1637
	14	2876	2477	1841	2977	2576	1876	2985	2610	2028	2788	2375	1703
	15	2934	2523	1904	3040	2625	1934	3040	2650	2083	2843	2420	1752

Step		ML Smart Size 07											
		Supply fan						Exhaust fan					
		Heat recovery operation			Bypass operation			Heat recovery operation			Bypass operation		
		UH	H	L	UH	H	L	UH	H	L	UH	H	L
SA Fan RPM setting (19(29)-2-...)	1	1919	1598	843	2007	1621	911	2118	1805	1137	1901	1563	843
	2	1975	1656	908	2060	1691	969	2162	1857	1192	1951	1612	893
	3	2030	1719	975	2113	1757	1030	2208	1914	1249	2005	1664	944
	4	2083	1777	1042	2166	1815	1085	2252	1965	1306	2053	1713	994
	5	2136	1835	1110	2219	1881	1144	2298	2017	1365	2101	1765	1045
	6	2189	1886	1177	2275	1939	1204	2342	2059	1421	2149	1814	1095
	7	2242	1939	1245	2328	2005	1262	2389	2105	1477	2195	1866	1146
	8	2292	1990	1307	2381	2062	1320	2432	2147	1535	2244	1912	1198
EA Fan RPM setting (19(29)-3-...)	9	2353	2047	1378	2441	2128	1393	2487	2198	1596	2298	1967	1262
	10	2419	2098	1449	2504	2189	1469	2547	2241	1653	2356	2020	1328
	11	2479	2141	1515	2565	2234	1537	2599	2281	1706	2408	2066	1387
	12	2543	2191	1580	2628	2285	1610	2657	2327	1763	2466	2110	1453
	13	2598	2237	1638	2689	2331	1676	2707	2367	1816	2518	2151	1513
	14	2659	2290	1702	2752	2381	1734	2760	2412	1875	2577	2195	1574
	15	2712	2333	1760	2810	2426	1788	2810	2450	1925	2628	2237	1620

This table refers to indicated values subject to tolerances.

In order to adjust the desired airflow value based on measurement at site, while increasing rpm you will obtain more air flow and while decreasing rpm, you will reduce air flow. If needed, kindly change fan speed to reach the target air flow.

Factory Configuration

Size02			
Supply		Exhaust	
Volume Flow Rate	ESP	Volume Flow Rate	ESP
300	100	300	100
RPM		RPM	
2966		2773	
17(27)-4-01			
19(29)-2-9		19(29)-3-3	

Size03			
Supply		Exhaust	
Volume Flow Rate	ESP	Volume Flow Rate	ESP
600	150	900	100
RPM		RPM	
2508		2400	
17(27)-04-01			
19(29)-2-6		19(29)-3-1	

Size04			
Supply		Exhaust	
Volume Flow Rate	ESP	Volume Flow Rate	ESP
1200	100	1200	100
RPM		RPM	
2912		2885	
17(27)-4-01			
19(29)-2-12		19(29)-3-8	

Size05			
Supply		Exhaust	
Volume Flow Rate	ESP	Volume Flow Rate	ESP
1500	100	1500	100
RPM		RPM	
2565		2455	
17(27)-4-02			
19(29)-2-9		19(29)-3-4	

Size06			
Supply		Exhaust	
Volume Flow Rate	ESP	Volume Flow Rate	ESP
2500	100	2500	100
RPM		RPM	
2546		2487	
17(27)-04-02			
19(29)-2-9		19(29)-3-5	

Size07			
Supply		Exhaust	
Volume Flow Rate	ESP	Volume Flow Rate	ESP
3000	100	3000	100
RPM		RPM	
2191		2105	
17(27)-04-01			
19(29)-2-12		19(29)-3-7	

“Field setting without preliminary selection”: adjust fan speed according to in duct flow measurement, as explained in the previous pages.

Settings for all configuration

Setting 17(27)-4: First choose the fan speed. Set it to high or ultrahigh.

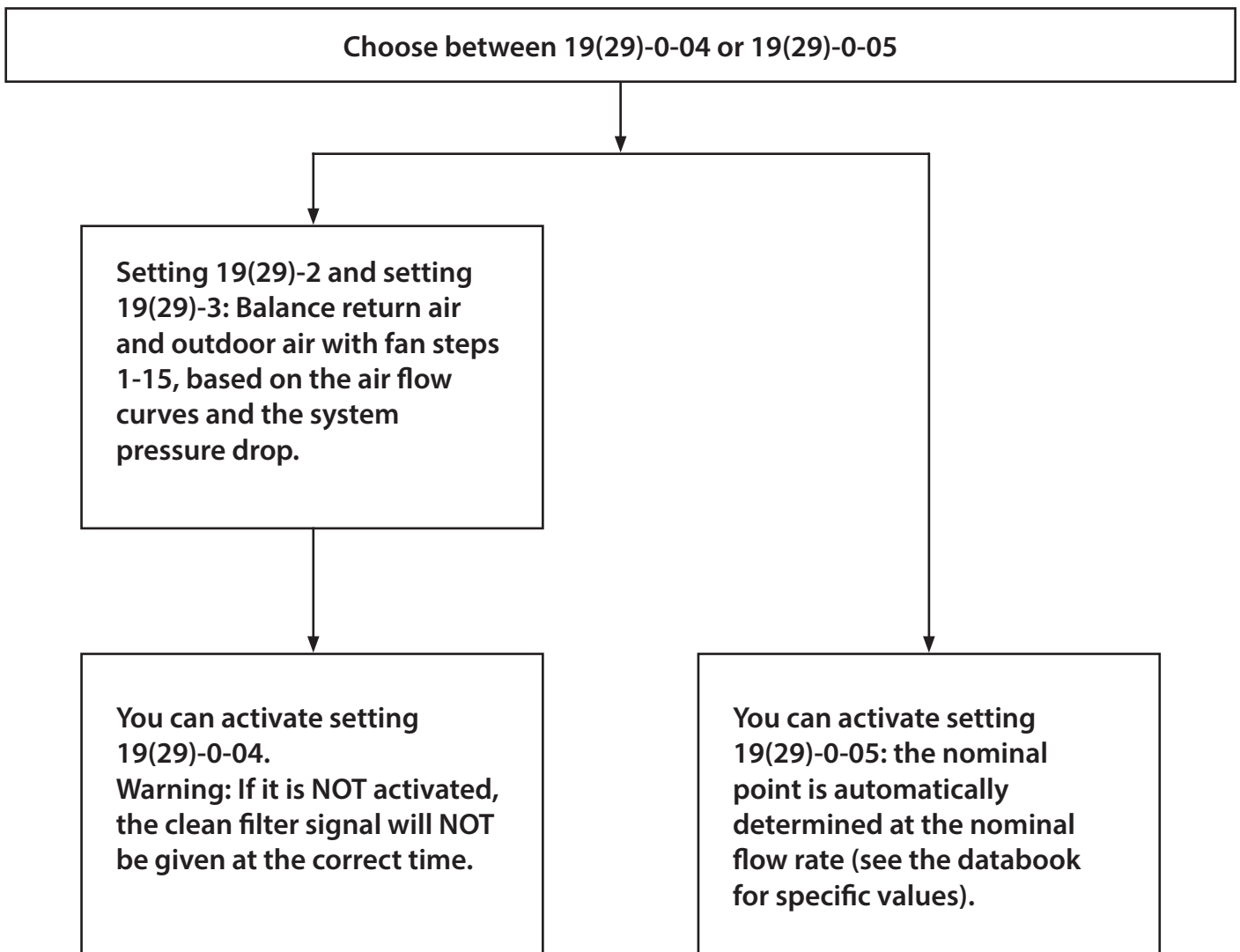

About setting 19(29)-0-04 and 19(29)-0-05

If the user interface is switched off while you are activating setting 19(29)-0-04 or 19(29)-0-05, the configuration is aborted. When you switch the user interface back on, the function starts from the beginning. Setting 19(29)-0-04 takes between 1 and 6 minutes to complete. You can check if the setting was completed successfully by checking if the field setting is changed to 0-01. Setting 19(29)-0-05 takes between 3 and 35 minutes to complete. You can check if the setting was completed successfully by checking if the field setting is changed to 0-02. You can ONLY activate these settings with clean filters. Make sure that the ducting pressure drop of the top and bottom units is balanced. The function starts as soon as it is selected and the user interface is on. Setting 19(29)-0-04 CANNOT be configured if the outside temperature is $\leq -10^{\circ}\text{C}$, which is out of the operation range. Setting 19(29)-0-05 CANNOT be configured if the outside temperature is $\leq 5^{\circ}\text{C}$. In this case error 65-03 is shown and the unit stops working. Change the setting to 19(29)-0-04. The setting CANNOT be configured if there are alerts or errors present. If booster fans are used, you can ONLY configure setting 19(29)-0-03. You can configure settings 19(29)-0-04 and 19(29)-0-05 for multiple units with 1 user interface.

About the user interface

Please read the manual supplied with the user interface for more detailed instructions.

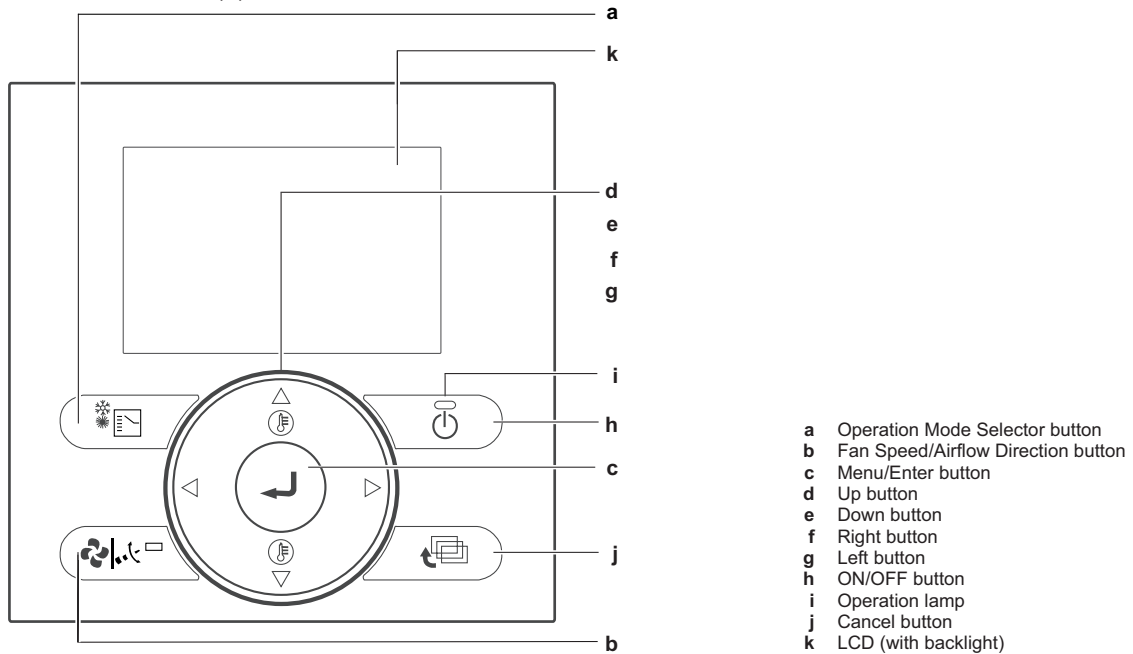

To change the ventilation rate

1. Press the Menu/Enter button to display the main menu.
2. Press the Up/Down buttons to select Ventilation and press the Menu/Enter button

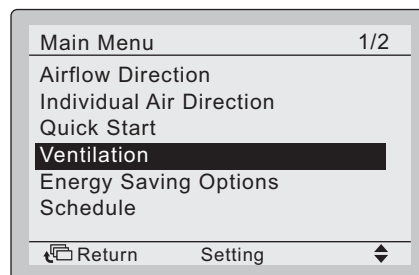

3. Press the Up/Down buttons to select Ventilation Rate and press the Menu/Enter button to confirm

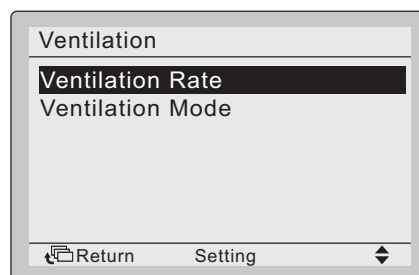

4. Press the Up/Down buttons to change the setting to Low or High and press the Menu/Enter button to confirm.

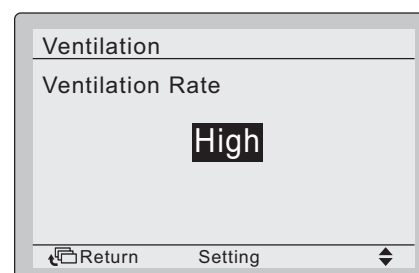

To select ventilation mode

Ventilation mode is used when cooling or heating is unnecessary, so only the heat reclaim ventilation units are operating.

1. Press the Operation Mode Selector button several times, until the ventilation mode is selected list

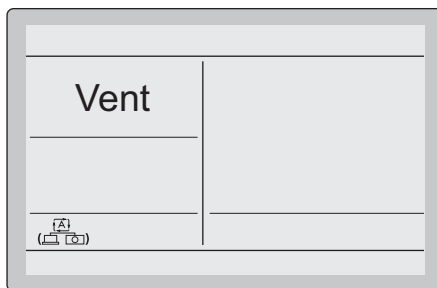

To change the ventilation mode

1. Press the Menu/Enter button to display the main menu.
2. Press the Up/Down buttons to select Ventilation and press the Menu/Enter button.

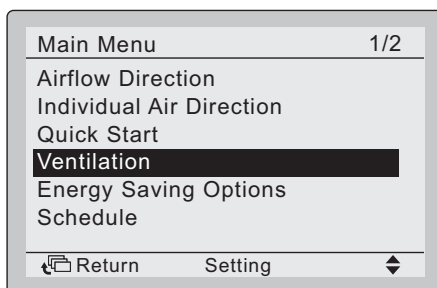

3. Press the Up/Down buttons to select Ventilation mode and press the Menu/Enter button.

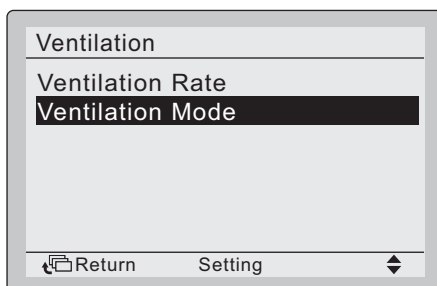

4. Press the Up/Down buttons to select the required ventilation mode. For more information about ventilation modes, see Ventilation modes in the installer and user reference guide.

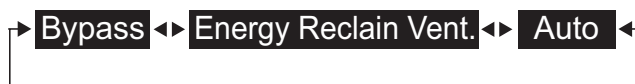
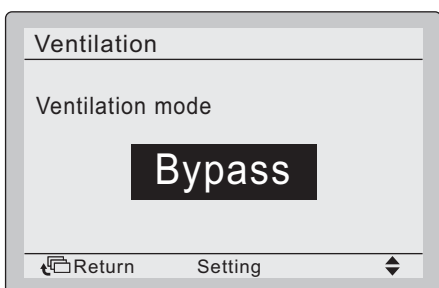

Ventilation modes

You can change the ventilation mode in the main menu

Mode	Description
Auto mode	Using information from the air conditioner (cooling, heating, fan, and set temperature) and heat reclaim ventilation unit (indoor and outdoor temperatures), this mode automatically changes between Energy Reclaim Ventilation and Bypass mode.
Energy Reclaim Ventilation mode	The outdoor air is supplied to the room after passing through a heat exchange element, where heat is exchanged with the return air.
Bypass mode	The outdoor air bypasses the heat exchange element. This means that outdoor air is supplied to the room without heat exchange with the return air.

Time to clean filter indication

When it is time to clean the filters, the following message or icon shows at the bottom of the basic screen:
Time to clean the filter.

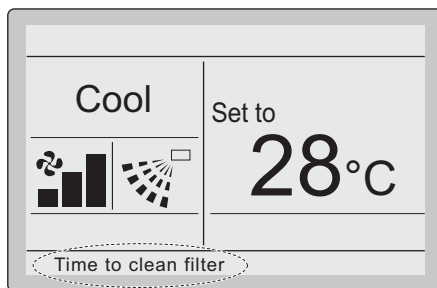

To remove time to clear filter indication

Press the Menu/Enter button

Press the Up/Down buttons to select Reset Filter Indicator.

Press the Menu/Enter button

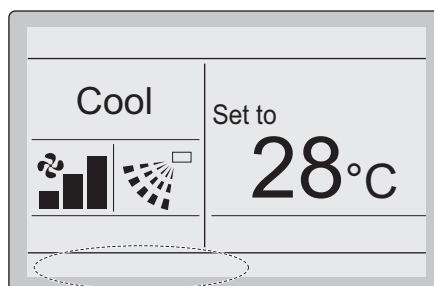
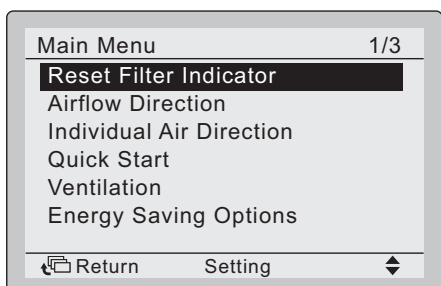

About error indications

If an error occurs, there is an error icon in the basic screen and the operation lamp blinks. If a warning occurs, ONLY the error icon blinks and the operation lamp does NOT. Press the Menu/Enter button to display the error code or warning and contact information.

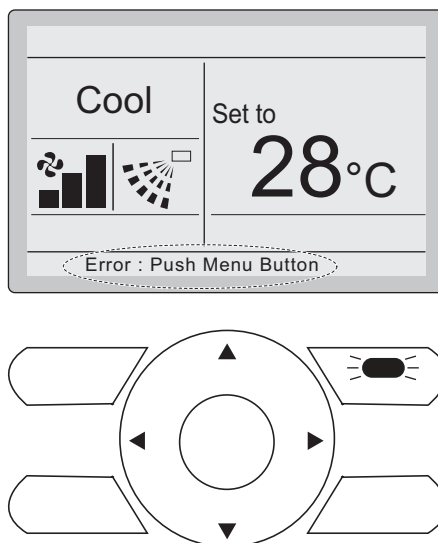

The error code blinks and the contact address and model name appear as shown below. In this case, notify your Daikin dealer about the error code.

Malfunction code	Praticular code	Description
A1		EEPROM failure
A6		Locked rotor
A6	22	Unstable fan rpm:failure of filter contamination
A8		Power supply malfunction
AJ		Capacity setting malfunction
C0		Generic error
C1		Fan communication error
C6		Malfunction of fan motor sensor or fan control driver
CH		CO2 sensor warning
US		Transmission error between the unit and user interface
U8		Transmission error between main user interface and sub user interface
UA		Wrong user interface installed
UC		Repeated central address
UE		Transmission error between the unit and centralised controller
60		External protection device activated
64	01	Indoor air thermistor (R1T) malfunction
64	02	Indoor air thermistor (R1T) out of operation range
65	01	Outdoor air thermistor (R2T) malfunction
65	02	Outdoor air thermistor (R2T) out of operation range
65	03	Functions 19(29)-0-04/05 not possible due to low outdoor temperature operation
6A		Damper-related malfunction
6A		Damper related malfunction + thermistor

In case of malfunction with the code on grey background, the unit still operates. However, make sure to have it inspected and repaired as soon as possible

Prevent of frost the heat-exchanger

- If electrical pre-heating is present:
- electrical pre-heating coil will prevent frosting of the heat-exchanger, modulating once the freshair temperature goes below the treshold value set at 0°C, in case of heater malfunction or not sufficient flow for its startup, a differential pressure switch will shutdown the unit until the defrosting.
- If electrical pre-heating coil is not present:
- a differential pressure switch will prevent frosting of heat exchanger, shutting down the unit once the frosting starts



The differential pressure switch will be set according to the nominal air flow. If the Compact L Smart will operate at different condition from nominal airflow, you MUST adjust the setting according to the chart below.

Frost prevent differential pressure switch factory settings						
Size	02	03	04	05	06	07
Pa	200	425	225	300	250	375

Factory settings for frost-protection Differential Pressure Switch:

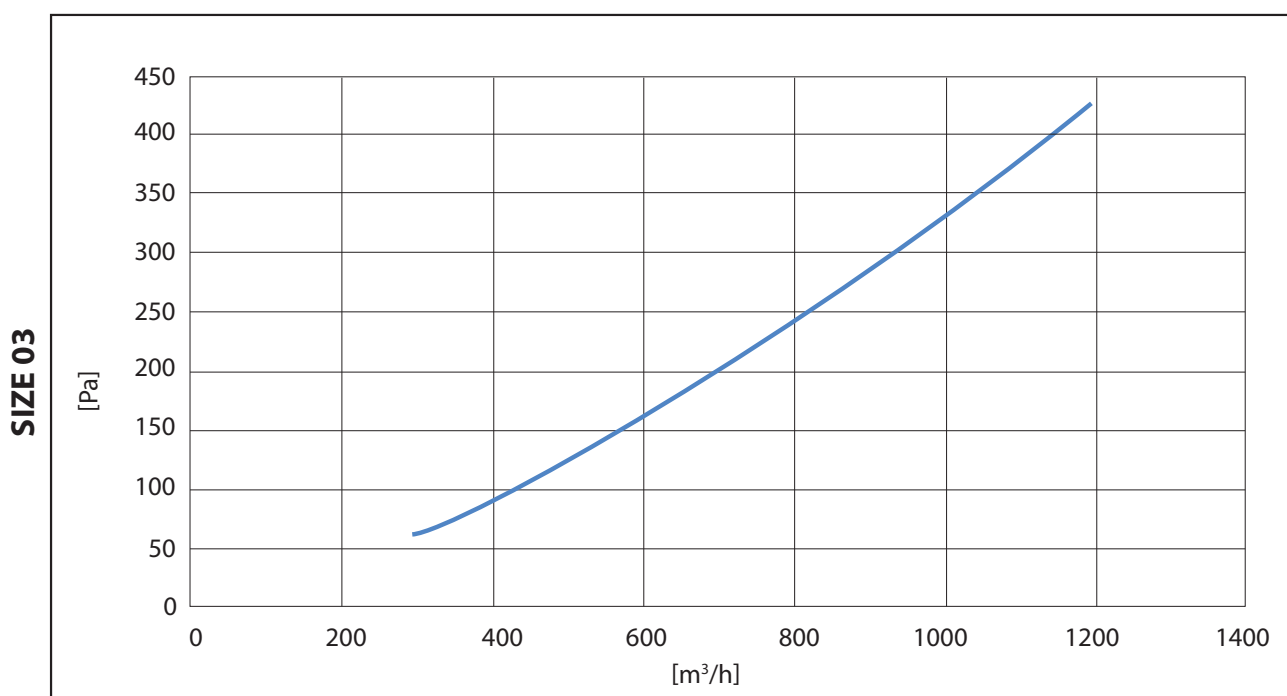
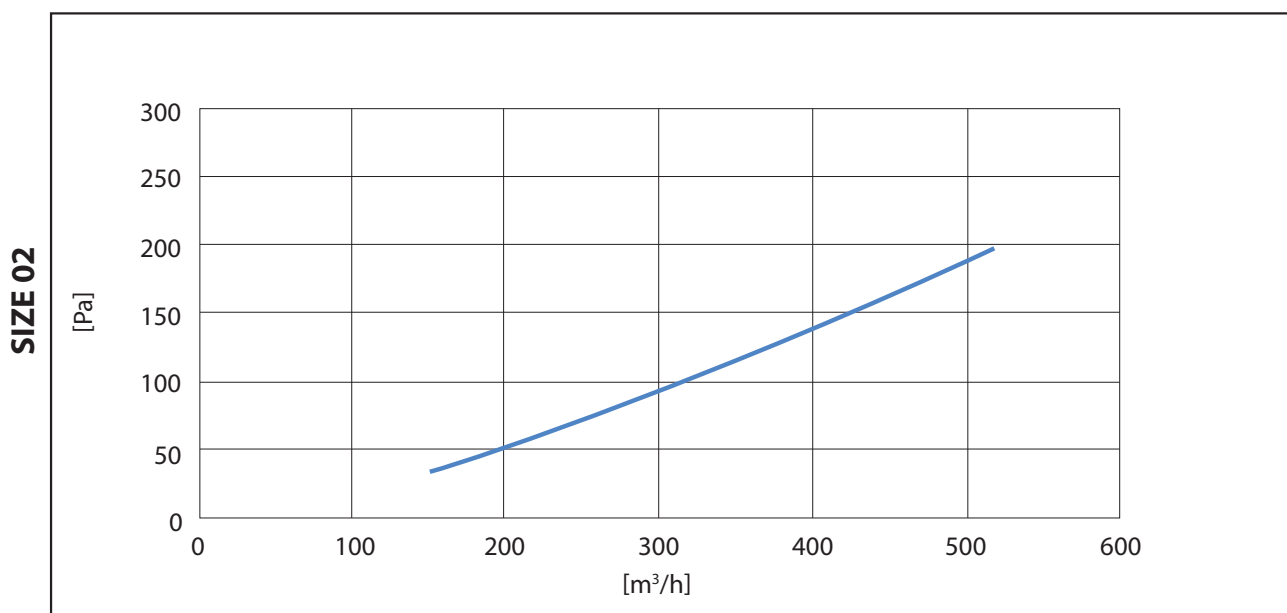

SIZE 04

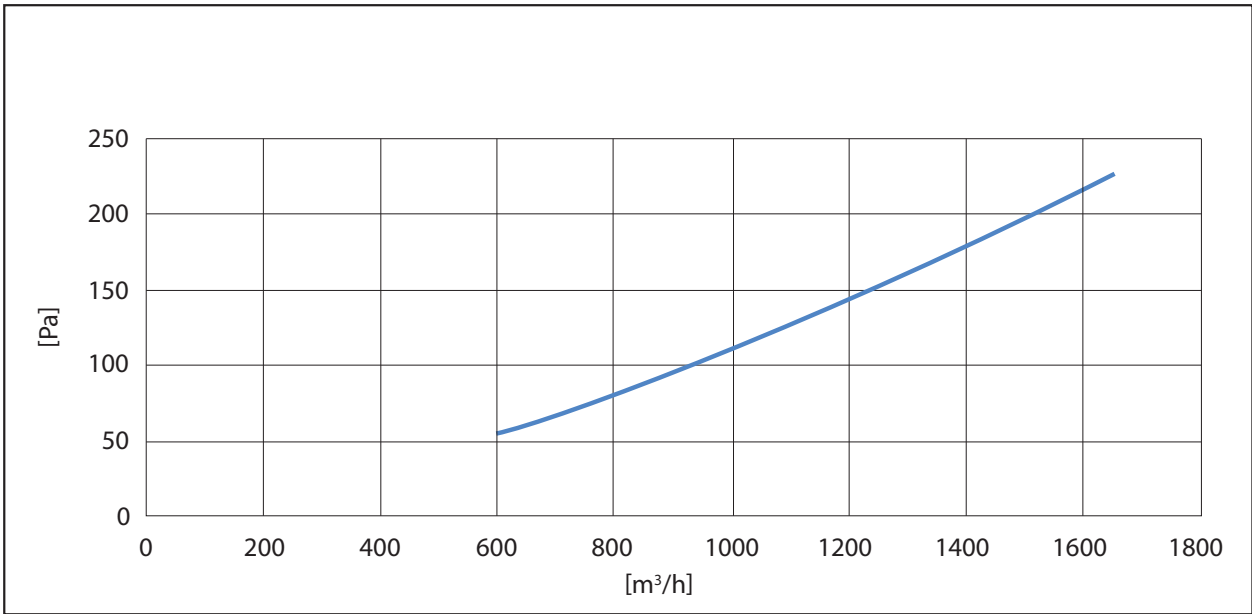

SIZE 05

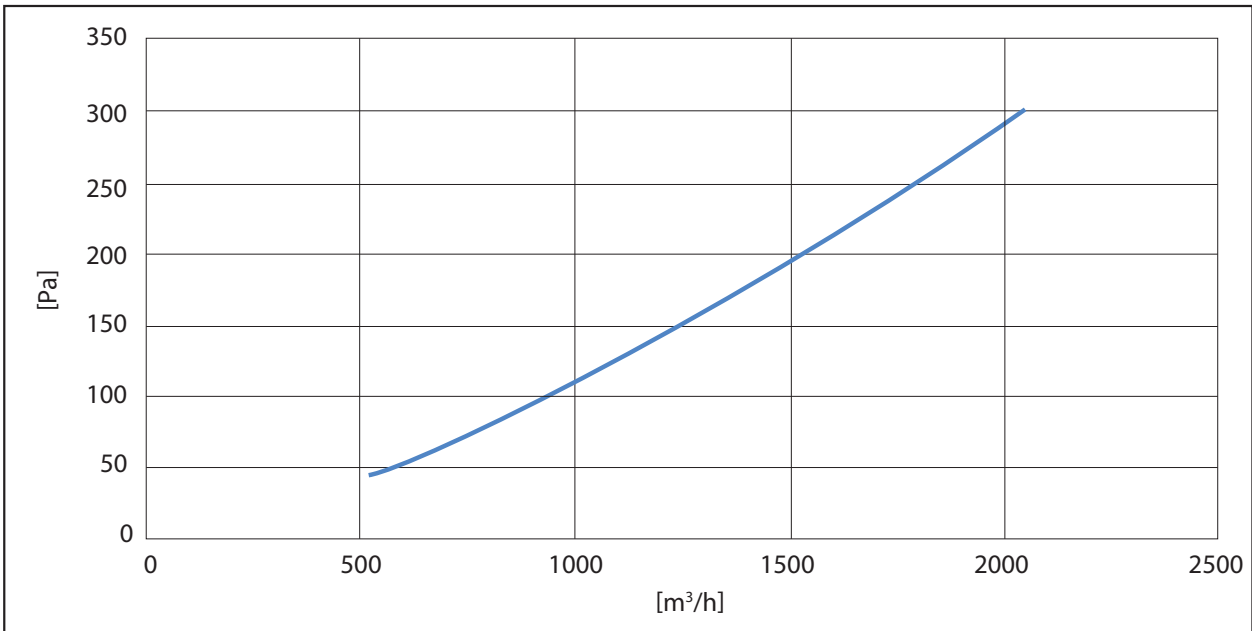

SIZE 06

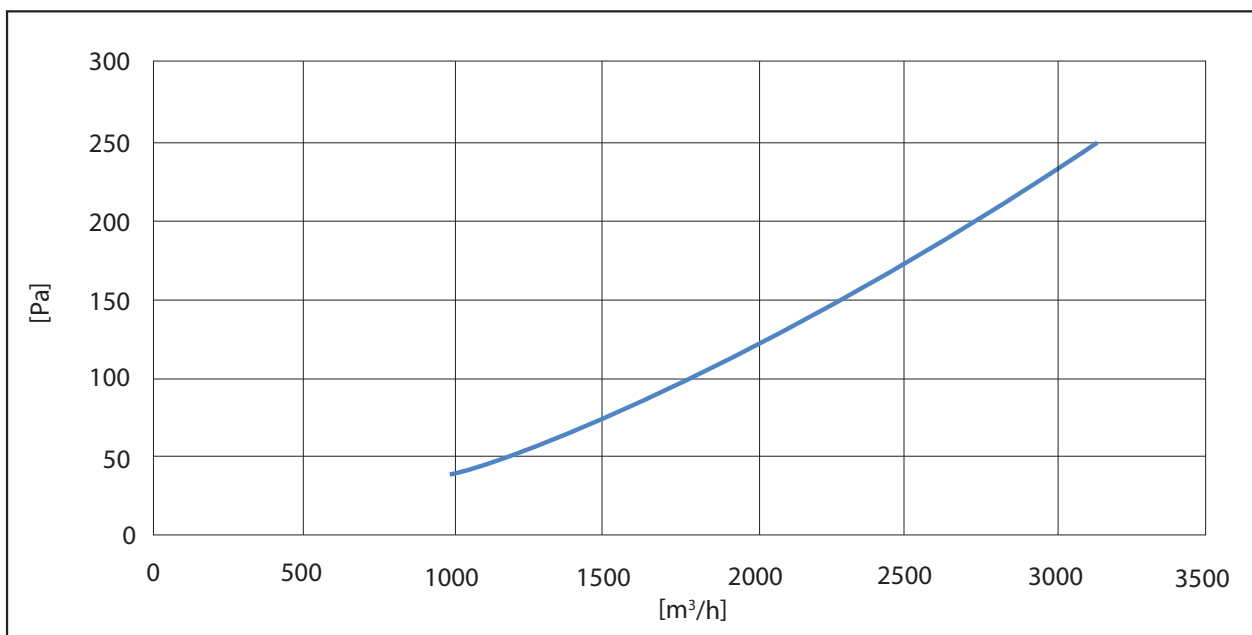

SIZE 07

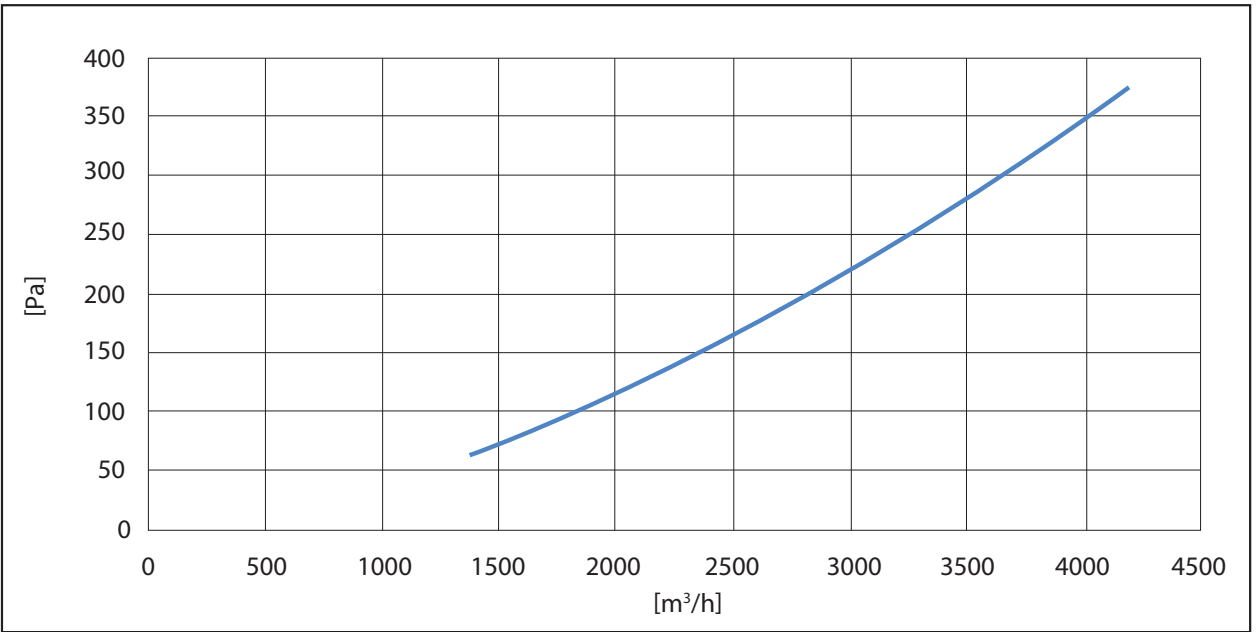

8 Maintenance

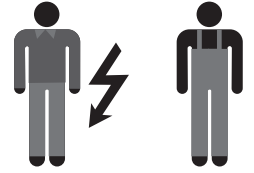

Safety precautions for maintenance



Ordinary and extraordinary maintenance must be carried out **solely by the operator assigned to perform maintenance** (mechanical and electrical maintenance staff) according to the regulations in force in the country of use and respecting the laws regarding systems and work safety. Remember that, by operator assigned to perform maintenance is meant the person who can work on the unit to perform ordinary and extraordinary maintenance, repairs and fine tuning. This person must be an expert operator, properly instructed and trained, given the risks involved in such operations.



Before performing any ordinary and extraordinary maintenance, the unit **must always be stopped (by disconnecting from the mains)** and **the EMERGENCY button engaged**. The switch must have a key that must be removed and held by the operator who will perform the operations until the end of the maintenance itself.



It is absolutely prohibited to remove any protections from moving parts and unit protection devices with the unit connected to the mains or operational. Adjustments made with safety devices disengaged must be performed **by a single person**, expert and authorised, and during this activity it is necessary to prevent access to the area of the unit by other people. Upon completing the adjustments with safety devices disengaged, the protections must be re-engaged as soon as possible.



During maintenance the operational space surrounding the unit for a distance of 1.5 metres must be free of obstacles, clean and well lit. It is prohibited for unqualified people to pass through or remain in this space.



Use personal protective clothing (safety shoes, safety glasses, gloves, etc.) compliant with regulations.



Before carrying out repairs or other work on the unit, **always declare out loud** your intentions to other operators who are located in the unit area and make sure that they have heard and understood the warning.



Ordinary maintenance

Proper maintenance of the systems maintains efficiency (reducing costs) and consistent performance over time, and increase the usable life of the equipment.

ACTIVITY	FREQUENCY			
	A	B	C	D
General cleaning of the unit.		√		
Check and eventual disassembly and washing of filters.				√
Replacing the filters (when they have deteriorated).	in case of alarm			
Clean the finned surfaces of the heat exchange coils (if provided) with a jet of compressed air and soft brush.	√			
Clean the exchange surfaces of of heat recuperators with a jet of compressed air and soft brush.	√			
Empty and clean the condensate collection basins.		√		
Visual inspection for corrosion, limescale, release of fibrous substances, any damage, abnormal vibrations, etc. (if possible, it is advisable to extract the components for a more thorough inspection).			√	
Check condensate drain and cleaning of siphons.		√		
Check the status of anti-vibration connections.	√			
Cleaning of the heat exchanger		√		
Check tightness of screws and bolts in the fan section.	√			
Check the impeller and various devices, with removal of any buildup.	√			
Check the integrity of piping connected to pressure gauges and pressure switches.		√		
Check the ground connection.		√		
Power connection terminal torque	√			

A: every year

B: every six months

C: every three months

D: every month

General information on cleaning procedures



Read the safety instructions at the beginning of this manual and page. 50



You should consult with your supplier of chemical products to choose the most suitable for cleaning the unit components.



For the cleaning method refer to the instructions of the detergent manufacturer and carefully read the safety data sheet (SDS).

As general guidelines, refer to the following rules:

- Always use personal protection (safety shoes, safety glasses, gloves, etc.).
- Use mild products (pH between 8 and 9) for washing and disinfecting, in normal concentrations. Detergents must not be toxic, corrosive, flammable or abrasive.
- Use a soft cloth or bristle brushes that do not damage the stainless steel surfaces.
- If you use water jets, the pressure should be less than 1.5 bar and the temperature must not exceed 60°C.
- To clean components like motors, damper motors, bearings, Pitot tubes, filters and electronic sensors (if applicable), do not spray water directly on them.
- After cleaning make sure that you have not damaged the electrical parts and the seals.
- Cleaning operations should not involve the lubricated parts, like rotation shafts, because this could affect their good operation and create problems with durability.
- For the cleaning of finned components or dampers use an industrial vacuum cleaner and/or a compressor. Attention, the compressed air flow must run opposite to the direction of airflow through the unit.
- To clean plastic components such as tapping points, grommets, cable glands, connecting pipes and clicks, use a cloth soaked in alcohol. We recommend carrying out the operation during the general cleaning of the unit and when replacing the filters. In case of the cleaning with soaked cloth it's not enough, please proceed to replace the plastic components.

Cleaning lamellar components

Remove the dust and fibres with a soft bristle brush or a vacuum cleaner.



Be careful when cleaning with compressed air because the exchanger package can be damaged. CLEANING with pressure jets is allowed if the maximum water pressure is 3 bar and a flat nozzle is used (40° - WEG 40/04 type).

Oils, solvents, etc. can be removed with water or hot grease solvents, by washing or immersion. Periodically clean the condensate drain tray and fill the drain siphon with water.

Vents

Periodically check that there are no new sources of contamination near the air intake. Each component must be checked periodically for the presence of contamination, damage and corrosion. The seal can be protected with glycerine-based lubricants or replaced with a new one, if worn.

Exchange coils

The coils must be cleaned at the slightest sign of contamination.

The coil should be cleaned and washed gently to avoid damaging the fins.

For cleaning using a **mild detergent** suitable for the purpose. Do not use alkaline, acidic or chlorine-based solutions.

THE coils can be washed with a slightly pressurised water jet (max. 1.5 bar). The jet must NOT contain chemicals or microorganisms. Also the water must be sprayed in the opposite direction to the air flow.

For pertinent accessories, refer to the enclosed documentation.

Fans

The fans can be cleaned with compressed air or by brushing them with soap and water or with a mild detergent.

Finish the cleaning by rotating the fan by hand to verify the absence of abnormal noises.

Cleaning filters



The unit must NOT be running when the filters are removed to avoid drawing in outside air that might be contaminated.

The filters must be cleaned often and carefully to prevent dust and microbial buildup. Usually, compact filters can be cleaned **two** or **three times** before they are replaced. As a general rule, replacement is required after 500-2000 hours of operation (it varies depending on the type of filter, refer to the directions of the manufacturer), but may need to be replaced much sooner if required.

Compact filters can be cleaned using a vacuum cleaner or by blowing on them with compressed air.

Only for versions with up-and-over doors: if the opening of the doors was difficult because of the narrowness of the available space, it is possible to remove them by unscrewing the screws that hold them. At the end of cleaning, it is mandatory to remount the doors.

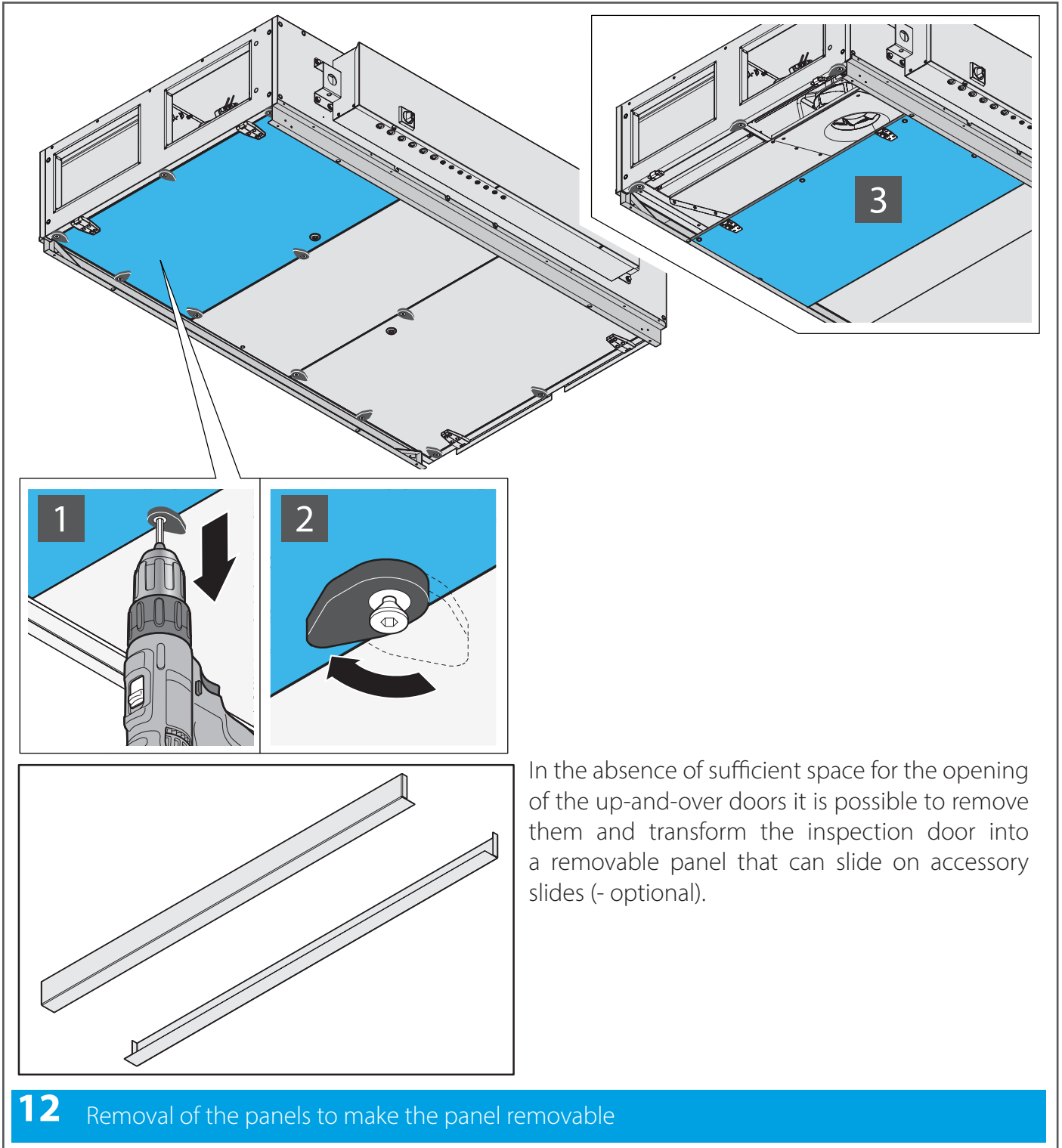

In the absence of sufficient space for the opening of the up-and-over doors it is possible to remove them and transform the inspection door into a removable panel that can slide on accessory slides (- optional).

Correct filter and pre-filter installation (in the event of replacement)

Verify proper installation of the prefilters located on special counter-frames with safety springs or guides. After removing the filters from the packing (that they are placed in to prevent deterioration during transport and at the installation site), insert them into the containment section, paying attention to ensure a rigid assembly and a perfect seal of the gaskets.



Remove the filters from their packaging only when ready to install them to avoid getting them dirty and contaminating them.



Make sure that the inside of the filter is not contaminated by external agents.

This operation should be carried out about one hour after the first start-up of the unit, the period during which the ducts are cleaned of dust and various debris. Proceeding in this way preserves the filtering sections that cannot be regenerated.

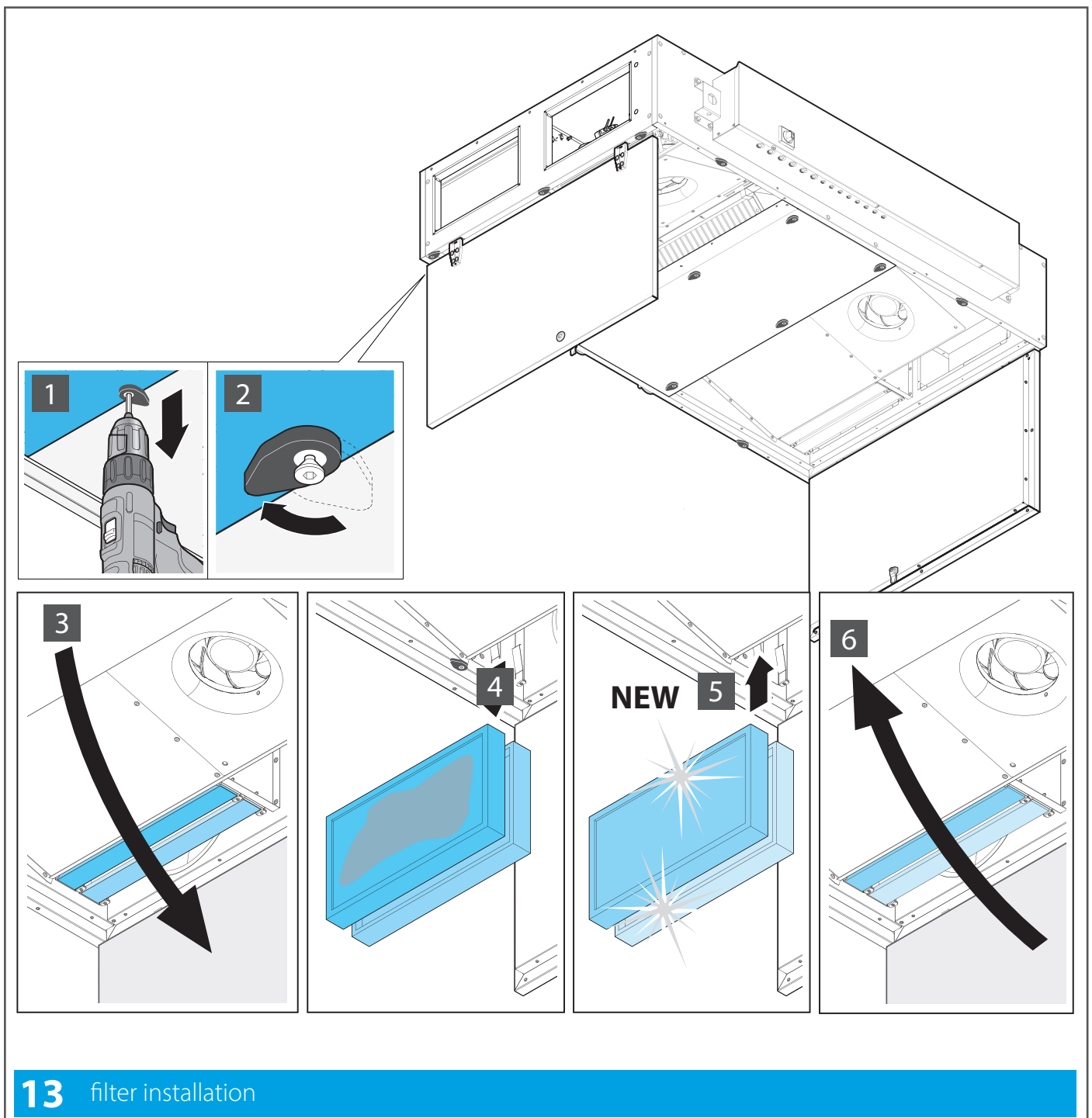

Extraordinary maintenance

One can not predict extraordinary maintenance as it is normally due to effects of wear or fatigue caused by the incorrect operation of the unit.

Replacement of parts



The replacement of parts should be performed by expert personnel:

- Qualified maintenance mechanic
- Qualified maintenance electrician
- Manufacturer technician

The unit is designed to be able to perform all the servicing necessary to maintain good efficiency of the components. However, it sometimes happens that a component fails due to malfunction or wear, so for replacement refer to the executive schematic.

These are the components that may need replacement:

- Filters ▶ see fig. 13
- Recovery/heating/cooling heat exchange coil ▶ see fig. 14
- fans
- by-pass

For some of these operations of a general nature we will not enter into detail as these are operations that fall within the abilities and professional expertise of the staff assigned to perform them.

Consumable components - Spare parts

During the operation of the unit there are particular mechanical and electrical components that are most subject to wear. These parts must be monitored in order to carry out their replacement or repair before they cause problems to the correct operation of the unit with consequent downtime (see table on page 60).

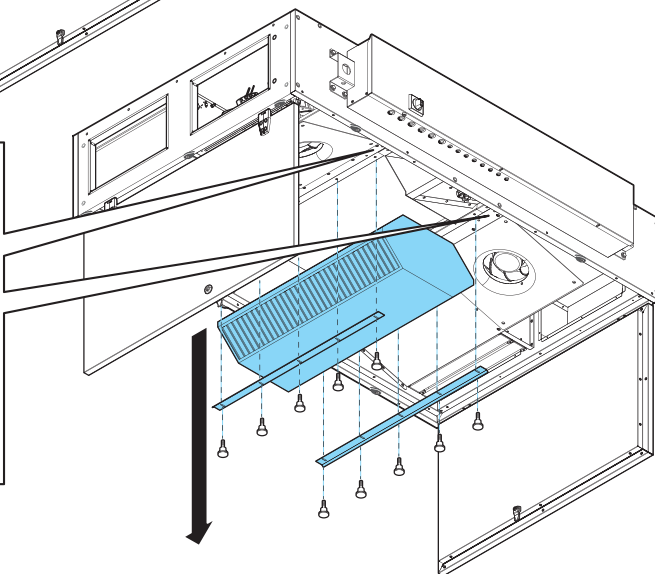
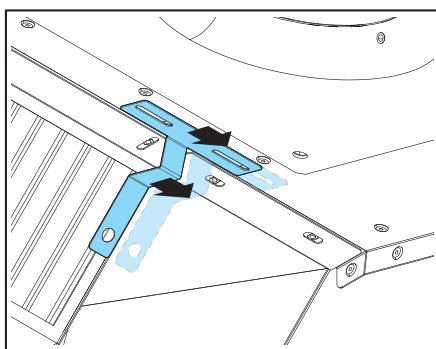
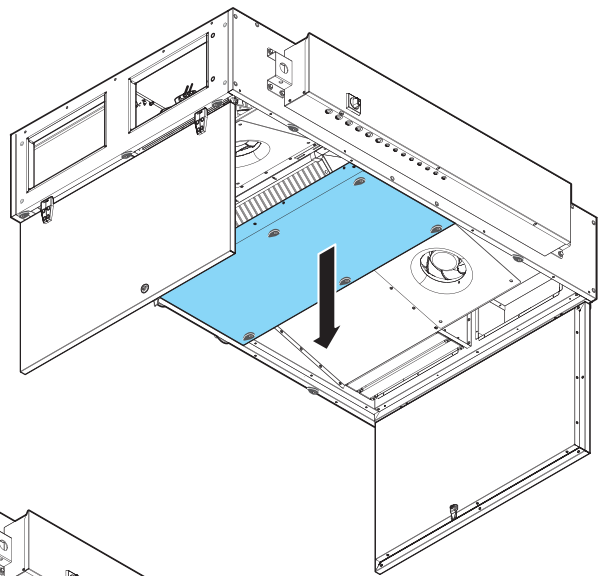
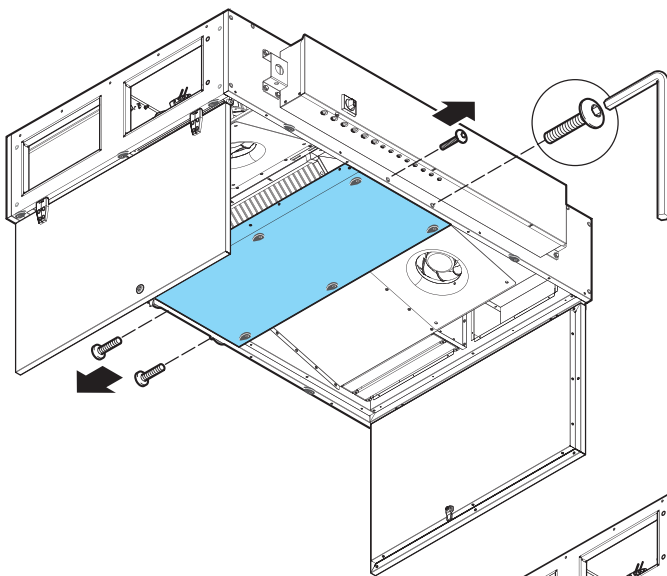
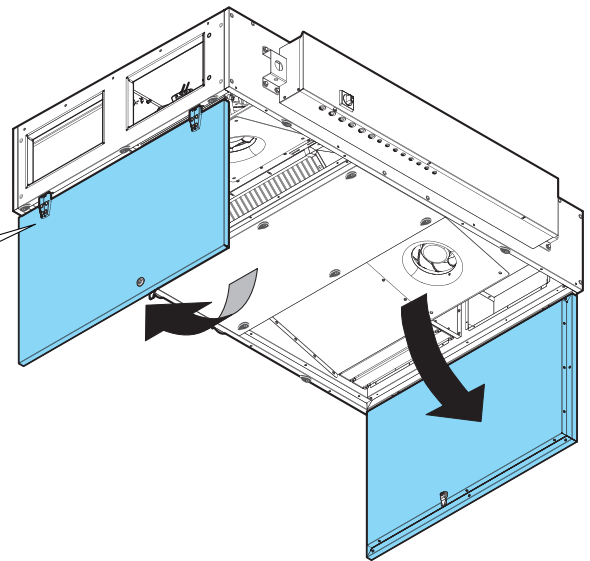
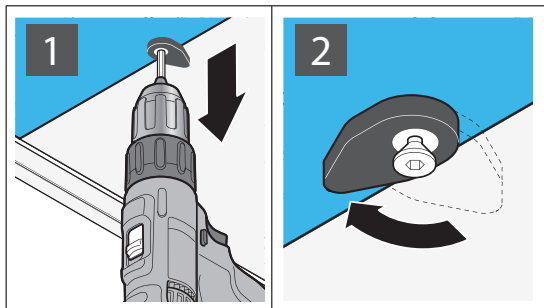

14 Removing the heat recovery unit

DEFINITION OF WASTE

Waste is any substance and object deriving from human activities or natural cycles that is abandoned or destined to be abandoned.

SPECIAL WASTE

Special waste includes:

- Residues from industrial, agricultural, artisanal, commercial and service processes that in quality or quantity are considered different from municipal waste.
- Deteriorated or obsolete unitry and equipment.
- Motor vehicles and their parts that can no longer be used.

HARMFUL TOXIC WASTE

Harmful toxic waste is all waste containing or contaminated by substances listed in the annex to the Italian Presidential Decree 915/52 implementing directives 75/442/EEC, 76/442/EEC, 76/403/EEC, 768/319/EEC. Following are described the types of waste that may be generated during the lifetime of an air handling unit:

- Cell filters from the suction unit.
- Waste oils and greases from lubricating the fan motor assembly.
- Rags or paper soaked with substances used for the cleaning of the various parts of the unit.
- Residues from cleaning the panelling.



Waste from the cell filters are to be handled as special waste or harmful toxic depending on their use, the sector and the environment in which they are used.

Waste and scraps may cause irreparable damage if dispersed in the environment.

ELECTRICAL/ELECTRONIC WASTE

Under art. 13 of Italian Legislative Decree no. 49 of 2014 "Implementation of the WEEE Directive 2012/19/EU on electrical and electronic equipment waste.



The logo with the crossed-out bin specifies that the product has been placed on the market after 13 August 2005 and that at the end of its useful life it should not be disposed of with other waste but rather must be collected separately. All equipment is made from recyclable metallic materials (stainless steel, iron, aluminium, galvanised steel, copper, etc.) in a percentage higher than 90% by weight. Before disposal make the equipment unusable by removing the power cord and closing any devices for closing compartments or cavities (where present). It is necessary to pay attention to the management of this product at the end of its life by reducing its negative impact on the environment and improving the effective use of resources, applying the principles of "he who pollutes pays", prevention, preparation for reuse, recycling and recovery. Remember that the illegal or improper disposal of the product may result in the application of sanctions provided for by current provisions of law.

Disposal in countries of the European Union

The EU Directive on WEEE equipment has been implemented differently by each country, so to dispose of this equipment we suggest contacting local authorities or the dealer to ask for the correct method of disposal.

Diagnostics

General diagnostics

The unit's electrical system includes quality electromechanical components and is therefore extremely durable and reliable over time.

Should there be any malfunctions due to malfunctions of electrical components it will be necessary to act as follows:

- Check the fuses of the power supply for the control circuits and if necessary replace them with fuses having the same specifications.
- Check if the thermal protection switch for the motor has been triggered or if its fuses have blown.

If this has occurred, it may be caused by:

- Motor overload due to mechanical problems. They need to be solved.
- Incorrect supply voltage. Verify the protection trip threshold.
- Malfunction and/or short circuits in the motor. Identify and replace the failed component.

Electrical maintenance

The unit does not require routine maintenance repairs.

Do not modify the unit for any reason and do not add other devices.

The manufacturer is not liable for resulting malfunctions and problems.

Further clarification is available by contacting the manufacturer's Customer Service.

Troubleshooting table

MALFUNCTION TYPE	COMPONENT	POSSIBLE CAUSE/SOLUTION
NOISE	Fan impeller	Impeller deformed, unbalanced or loose
		Nozzle damaged
		Foreign bodies in the fan
		Motor or fan not attached well
	Bearings	Bearing worn or deteriorated
	Motor	Incorrect supply voltage
		Worn bearings
		Contact between the rotor and stator
	Ducts	Excessive speed in the ducts
		Anti-vibration joint too taut
INSUFFICIENT AIR FLOW	Ducts	Load losses superior to the demand
		Obstructions in the ducts
	Filters	too dirty
Heat exchange coils	too dirty	
	Ducts	Terminals not installed
	Unit	Filters not inserted
		Access doors open
		Dampers not calibrated
INSUFFICIENT THERMAL EFFICIENCY	Heat exchange coil	Incorrect connection of inlet/outlet piping
		Heat exchange coil dirty
		Air bubbles in the pipes
		Excessive air flow
	Electric pump	Insufficient water flow
		insufficient pressure
		Wrong direction of rotation
	Fluid	Temperature different from the project
		Incorrect regulation bodies
WATER LEAK	Heat exchange coil	Leak from the heat exchange coil due to corrosion
	Fan section	Dragging of drops due to high air velocity
		Siphon connected incorrectly
		Clogged "overflow" drain

DAIKIN APPLIED EUROPE S.p.A. Via Piani S. Maria, 72 - 00072 Ariccia (Rome) Italy - www.daikinapplied.eu

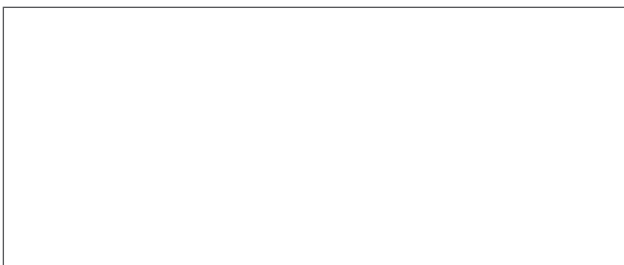

This publication is drawn up only as technical support and does not constitute a binding commitment for Daikin Applied Europe S.p.A. Daikin Applied Europe S.p.A. has drawn up the content to the best of its ability. No explicit or implicit guarantee is given as to the completeness, precision or reliability of its content. All the data and specifications contained herein are subject to change without notice. The data stated at the time of the order prevail. Daikin Applied Europe S.p.A. accepts no liability whatsoever for any direct or indirect damage, in the broadest sense of the word, deriving from or associated with the use and/or interpretation of this publication.
All content is protected by the copyright of Daikin Applied Europe S.p.A.

D-EIMAH03411-24_00EN