



Installation, use and
maintenance manual

Compact R

D-EIMAH04002-26_00EN

› Compact R

Translation of the original instruction

REV	00
DATE	February 2026
SUPERSEDES	

The Compact R heat recovery units guarantee high internal air quality with low energy costs. The range of items is divided into seven sizes, customisable with the addition of external optional.

Armed with an extremely flexible development, Daikin air handling units are able to satisfy all types of technical requirements.

Daikin systems guarantee respect for the environment since they are based on high levels of energy efficiency. Reduced ecological impact and low energy consumption make Daikin recovery units ideal for any type of market.

Contents

Assembly instructions

Important warnings 4

Purpose of the manual	4
Intended use of the unit	4
Important warnings	4
Safety regulations	5
Residual risks	8

Unit characteristics 10

Environmental conditions	10
Environmental contamination	10
Noise	10
Floor and air duct specifications	11
Technical data	12
Summary of unit operation	14

Receipt of the boxes 15

Transport 16

After unpacking	19
Unpacking and integrity check	19
Product nomenclature	20
Storage waiting for installation	21

Installation 22

Installation procedure	22
Commissioning	27

Maintenance 28

Safety precautions for maintenance	28
Ordinary maintenance	29
General information on cleaning procedures	30
Correct filter and pre-filter installation	32
Extraordinary maintenance	34
Replacement of parts	34
Consumable components - Spare parts	34

Diagnostics 37

General diagnostics	37
Electrical maintenance	37
Troubleshooting table	38
Repair log	39

1 Important warnings



The pictogram shows a situation of immediate danger or a dangerous situation that might cause injuries or death.



The pictogram shows that it is necessary to adopt suitable behaviour in order to avoid jeopardising staff safety and cause damages to the equipment.



The pictogram shows particularly important technical information that should be taken into consideration by the people installing or using the equipment.

Purpose of the manual

The purpose of this **manual** is to guide the installer and qualified operator in the installation, maintenance and proper and safe use of the equipment. For this reason, **it is mandatory for all personnel involved in installation, maintenance and supervision of the unit to read this manual.**

Contact the manufacturer if any points are unclear or difficult to understand.

This manual contains information regarding:

- Technical specifications of the unit.
- Instructions for transport, handling, installation and assembly.
- Use.
- Information for instructing personnel authorised for its use.
- Maintenance activities.

All information refers in general to any unit of the Compact R range. All the units are shipped together with a **technical schematic** indicating the specific weight and size of the unit received. It must be considered an integral part of this manual and therefore it must be kept with the utmost care in all its parts.

If the manual or drawings are lost, please request a new copy from the manufacturer, specifying the unit serial number as specified on the label on the unit.

In the case of divergent information between this manual and the schematic, the schematic will prevail.

Intended use of the unit

This appliance has the function of treating the air intended to condition civil and industrial environments. Any other use is not in accordance with the intended use and therefore dangerous.

This range of units is designed to be used in NON-explosive environments.

If the unit is used in critical situations, by type of system or environmental context, the customer must identify and adopt the technical and operational measures to avoid damage of any kind.

Safety regulations

Skills required for the installation of the unit



Installers must perform operations according to their professional qualifications: all activities not within one's expertise (i.e. electrical connections) must be carried out by specialised and qualified staff so as not to endanger one's safety and the safety of the other operators interacting with the unit.



Transport and equipment handling operator: authorised person with recognised expertise in using transport and lifting equipment.



Technical installer: expert technician, sent or authorized by the manufacturer or its representative, with adequate skills and training to install the unit.

Assistant: technician subject to care obligations while lifting and assembling the equipment. He must be suitably trained and informed about the operations to perform and the safety plans of the site/installation location.

In this manual, the technician competent to carry out each operation is specified.

Skills required for the use and maintenance of the unit



Generic operator: AUTHORISED to run the unit using commands placed on the keypad of the electrical control panel. Performs only unit control operations, power on/off.

Maintenance mechanic (qualified): AUTHORISED to carry out maintenance, adjustments, replacement and repair of mechanical parts. It must be a person competent in mechanical systems, therefore able to perform mechanical maintenance in a satisfactory and safe manner, must possess theoretical preparation and manual experience. NOT AUTHORISED to work on electrical systems.

Manufacturer's technician (qualified): AUTHORISED to perform complicated operations in every situation. Operates in accordance with the user.



Maintenance electrician (qualified): AUTHORISED to perform service of an electric nature, adjustments, maintenance and electrical repairs. AUTHORISED to operate in the presence of an active electrical connection inside the control panels and junction boxes. It must be a person competent in electronics and electrical engineering, therefore able to work on electrical systems satisfactorily and safely, must possess theoretical knowledge and proven experience. NOT AUTHORISED to work on mechanical systems.



Installers, users and maintenance technicians may NOT operate on the unit if:

- they are not experienced or responsible or if they are minors;
- they have a physical disability or are not in perfect physical/psychological condition;
- they are not skilled in managing the unit operating cycle;
- they have not taken part in theoretical/practical preparation training alongside an expert unit operator or controller, or alongside one of the manufacturer's technicians.

In this manual, the technician competent to carry out each operation is specified.



Read this manual carefully before unit installation and maintenance and keep it for any further future consultation by the various operators. Do not remove, tear out or rewrite any part of this manual.



All installation, assembly, electrical connections and standard/non-standard maintenance must be carried out solely by **technicians who comply with legal requirements**, only after turning off the power supply to the unit, and only using personal protective equipment (e.g. gloves and protective eyewear), in compliance with the standards in force in the country where the unit is used, and in compliance with the regulations on systems and safety in the workplace.



Installation, use or maintenance other than those specified in the manual may cause damage, injury or death, invalidate the warranty and relieve the Manufacturer of any liability.



Use protective clothing and suitable equipment while handling or installing the equipment, in order to prevent accidents and safeguard your own and other people's safety. Individuals not assigned to installation or maintenance are NOT allowed to stand or pass through the work area while the unit is assembled.



Disconnect the equipment from the mains before installing or maintaining it.



Before installing the equipment, check that the systems comply with the legal provisions in force in the country of use and meet the specifications on the serial number plate.



It is the responsibility of the user/installer to check the static and dynamic stability relative to the installation and to arrange environments so that **people who are not competent or authorised DO NOT have access to the unit or to its commands**.



It is the responsibility of the user/installer to make sure that **weather conditions** do not affect the safety of persons and property during installation, use and maintenance.



Make sure the air intake is not located near any exhausts, flue-gases or other contaminating elements.



Do not install the equipment in places exposed to strong winds, salt air, open flames or temperatures exceeding 46°C (115°F).



After installation is complete, instruct the user on the correct use of the unit.

If the equipment does not work or functional or structural alterations are noted, disconnect it from the mains and contact a service centre authorised by the Manufacturer or Retailer, without attempting to repair it on your own. For any replacements request the use of original spare parts.

Unauthorised actions, tampering or modifications that do not follow the information provided in this manual can cause damage, injuries or fatal accidents and void the warranty.

The serial number plate on the unit provides important technical information, essential in case of unit maintenance or repairs. We recommend that you do not remove, damage or modify it.

In order to ensure correct and safe conditions of use, it is recommended to have the unit maintained and checked at least annually by a service centre authorised by the manufacturer or dealer.

Failure to follow these instructions may cause damage and injuries, even fatal, voids the warranty and relieves the Manufacturer of any liability.

Residual risks

Despite having implemented and adopted all the safety measures indicated by applicable regulations, some residual risks remain. In particular, in some operations of replacement, adjustment and tooling maximum attention is always required in order to work in the best possible conditions.

List of operations with residual risks

Risks for qualified personnel (electrician and mechanic)

- Handling - during unloading and handling it is necessary to pay attention to all the steps listed in this manual regarding the points of reference
- Installation - during installation it is necessary to pay attention to all the steps listed in this manual regarding the points of reference
The installer must ensure the static and dynamic stability of the unit's site of installation.
- Maintenance - during maintenance it is necessary to pay attention to all the steps listed in this manual, and in particular to high temperatures that may be present in the heat transfer fluid lines to/from the unit.
- Cleaning - the unit must be cleaned only when it is switched off, by turning off the switch installed by the electrician and the switch located on the unit itself. The key for interrupting the power supply must be kept by the operator until the end of the cleaning operations. Internal cleaning of the unit must be carried out using the protections required by current regulations. While the inside of the unit does not contain particular hazards, it is necessary to pay the utmost attention so that accidents do not occur during cleaning. The heat exchange coils that have a potentially sharp finned pack must be cleaned using protective glasses and gloves suitable for handling metals.

During adjustment, maintenance and cleaning there are residual risks of variable entity. Being operations that must be performed with guards disabled, it is necessary to pay particular attention in order to avoid damage to persons and things.



Always pay close attention when performing the operations specified above.

Remember that these operations must always be performed by authorised personnel.

All work must be completed in accordance with the legal provisions relating to work safety.

Remember that the unit in question is an integral part of a larger system that includes other components, depending on the final characteristics of realisation and the mode of use. Therefore in the end it is the responsibility of the user and assembler to assess the residual risks and their respective preventive measures.

Safety devices



















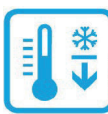











The unit is equipped with safety devices to prevent risks of damage to persons and for proper operation. Always pay attention to the symbols and safety devices on the unit. It should **only** operate with the safety devices engaged and with fixed or movable guards installed correctly and in the proper position.







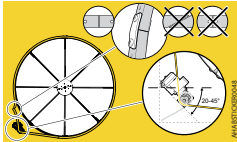
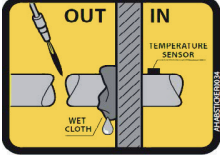

If during installation, use or maintenance the safety devices have been temporarily removed or disabled, the unit can be operated **exclusively** by the qualified technician who made this change. It is **mandatory** to prevent other people's access to the unit. When finished, restore the devices to their proper status as soon as possible.

Information signs

 Fresh air right 62x62 mm	 Fresh air left 62x62 mm	 Damper 62x62 mm	 Cold water outlet 62x62 mm	 Condensate drain 62x62 mm
 Exhaust air right 62x62 mm	 Exhaust air left 62x62 mm	 Drop separator 62x62 mm	 Hot water outlet 62x62 mm	 Antifrost 62x62 mm
 Air supply right 62x62 mm	 Air supply left 62x62 mm	 Fans 62x62 mm	 Filter 62x62 mm	 DAIKIN 310x70 mm
 Return air right 62x62 mm	 Return air left 62x62 mm	 Electric coil 62x62 mm	 Heat exchange coil 62x62 mm	 Unit label 102x102 mm
 Cold water inlet 62x62 mm	 Heat recuperator 62x62 mm	 Liquid coolant inlet 62x62 mm	 Moving parts 62x62 mm	 EUROVENT CERTIFIED PERFORMANCE 135x45 mm
 Hot water inlet 62x62 mm	 Humidification 62x62 mm	 Vapour coolant outlet 62x62 mm	 Silencer 62x62 mm	

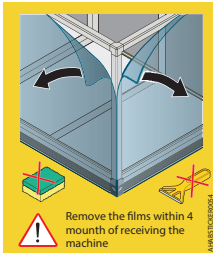
Safety signs

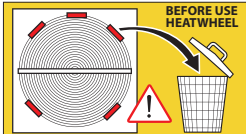
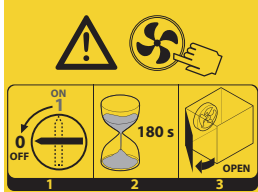
 WARNING Lifting	 Belt tensioning	 Risk of brazing the temperature sensor
 POSITIVE PRESSURE SAFETY HANDLE Safety handle positive pressure	 Remove IMMEDIATELY the films at receiving the machine	 Grounding
 FIRE RISK CLOGGED FILTERS INFLAMMABLE DANGER D'INCENDIE FILTRES ENPOUSSIERES INFLAMMABLES PELIGRO DE INCENDIO FILTROS COLMATADOS INFLAMABLES PERICOLO DI INCENDIO FILTRI INTASATI INFLAMMABILI BRANDGEFAHR VERSCHMUTZTE FILTER ENTFLAMMBAR Fire hazard	 Remove the films within 4 month of receiving the machine	 Electric shock hazard
 MOVING MACHINERY ELECTRIC SUPPLY LIVE BEWEGLICHE TEILE MOTOR UNTER SPANNUNG TOGLIERE CORRENTE PRIMA DI APRIRE CLEAR ELECTRIC SUPPLY BEFORE OPENING VOR ÖFFNEN DER TÜR ANLAGE SPANNUNGSLOS SCHALTEN Electrical hazard	 BEFORE USE HEATWHEEL Removal of heat wheel blocks before the unit first start-up	 Danger of running fans

2 Unit characteristics

Environmental conditions



Compact R heat recovery units are designed for use in indoor environments, installed on the floor. The unit cannot operate in environments containing explosive material and with a high concentration of dust.



Outside air temperature for outdoor installation	-30°C to +46°C *
Outside air temperature for indoor installation	-38°C to +46°C *
Temperature of environment with the unit off (e.g., storage, transport, etc.)	from -40°C to +50°C
Protection degree	IP54

*Note: from -16°C is recommended a preheating (water or electric)
 relative humidity < 50% RH at 40 °C
 maximum operating altitude < 1000m

Thanks to its modularity, each unit is able to adapt to different needs in terms of air flow and thermodynamic treatments.

The optimised choice of every detail, the search for maximum efficiency in each component, the adoption of specific materials and constructive solutions transform environment friendliness and energy savings into valid and advanced technological solutions.

Environmental contamination

Depending on the installation operating environment, specific regulations must be followed and all the necessary precautions must be taken to avoid environmental issues (a system that operates in a hospital or chemical environment can have problems different from those in other sectors, even from the point of view of disposal of consumable parts, filters, etc.).

It is mandatory for the buyer to inform and train workers regarding proper procedures.

Noise



The units have been designed and manufactured in such a way as to produce sound emissions below the threshold of **70 dB(A)**. If the unit is switched on without any ducts and the fans are set to 100% power, the noise generated by the components may exceed 70 dB(A), reaching a maximum value of 77 dB(A). It should be noted that every environment

has its own acoustic characteristics that can greatly affect the pressure values perceived during operation, therefore it is necessary to consider the noise data provided as a point of reference, while it is up to the buyer to carry out the specific phonometric surveys on the installation site and in the real conditions the unit will be used.

Floor and air duct specifications

The **floor** where you plan to install the unit **must** be:

- perfectly flat and without roughness;
- vibration resistant;
- able to **support the weight of the equipment considering an appropriate safety margin** see table of technical data on page 12).

The equipment installed on the floor can adapt easily to the presence of a false floor.

If provided, the **air ducts** must be connected directly to the unit, taking care to insert an optional accessory as a suitable anti-vibration system between the unit itself and the duct. When assembly is completed they must not be taut, in order to avoid damage and transmission of vibrations.

To ensure the seal of the connections and the integrity of the unit, it is essential that the air ducts be supported by special brackets that do not weigh directly on the unit.

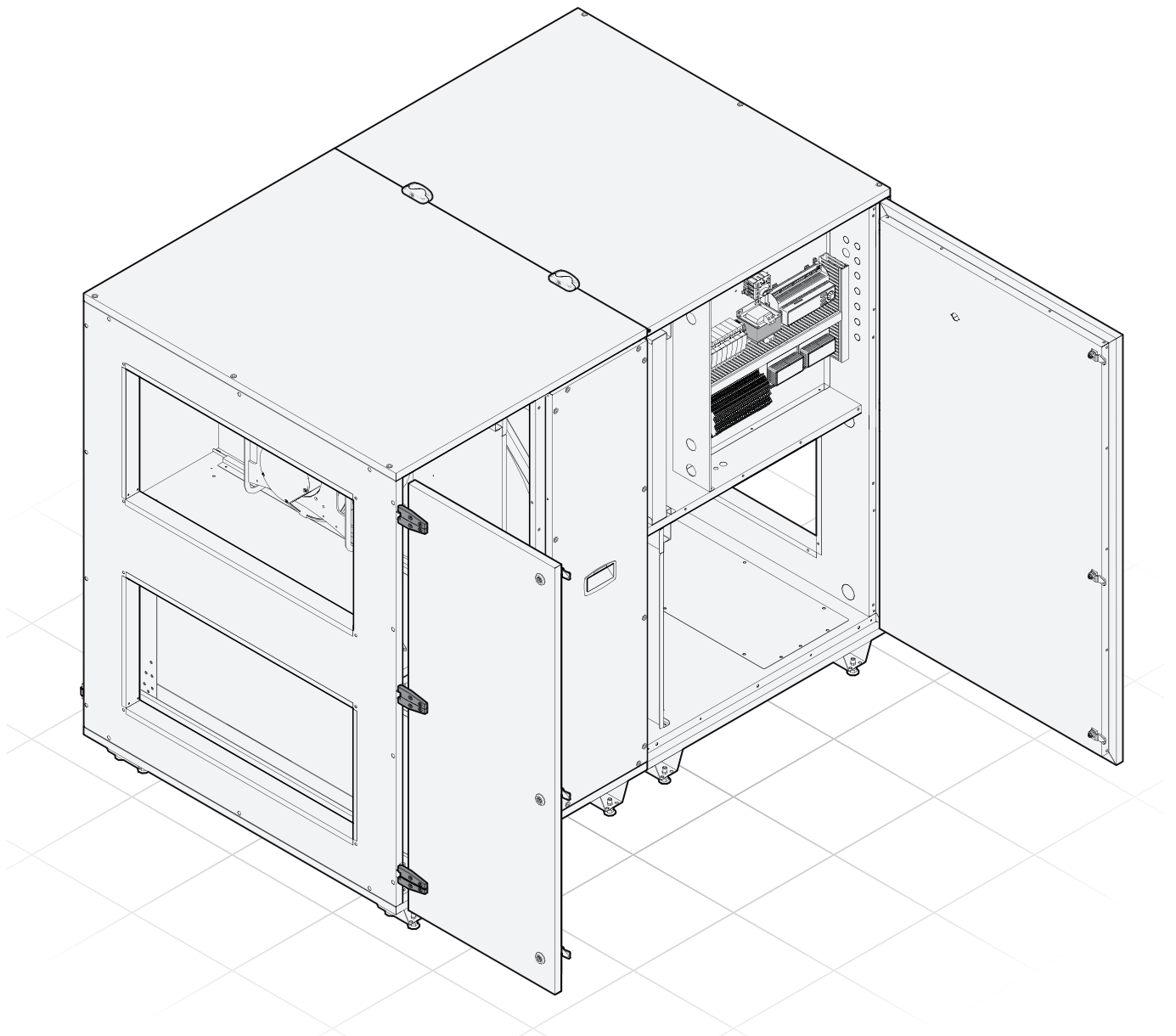

Technical data

DIMENSIONAL TABLE	SIZE							
		1	2	3	4	5	6	7
Gross weight	kg	160	180	245	285	335	365	420
Length (A)	mm	1614	1635	1720	1735	1751	1751	1751
Width (B)	mm	650	790	790	890	990	1100	1300
Height (C)	mm	960	1050	1150	1250	1400	1450	1700
Minimum clearance (D)	mm	1000		1200		1400		1600

WEIGHT TABLE	SIZE							
		1	2	3	4	5	6	7
Gross weight with packaging	kg	160	180	245	285	335	365	420
Unit weight	kg	140	160	225	265	310	340	395
Filter weight	kg	2x 0.6	2x 0.6	2x 0.7	2x 0.8	2x 1.0	2x 1.2	2x 1.3
Fan weight	kg	2x 3.0	2x 8.5	2x 9.3	2x 10.0	2x 18.0	2x 18.0	2x 22.0
Heat wheel weight	kg	35	43	43	50	58	67	85
QE door weight	kg	1x 8.5	1x 9.5	1x 12.0	1x 13.0	1x 15.0	1x 13.0	1x 18.0
Filter door weight	kg	1x 6.5	1x 4.0	1x 8.0	1x 4.5	1x 5.0	1x 15.0	1x 6.0
HEX panel weight	kg	1x 3.5	1x 7.5	1x 4.0	1x 9.0	1x 10.0	1x 5.0	1x 12.0

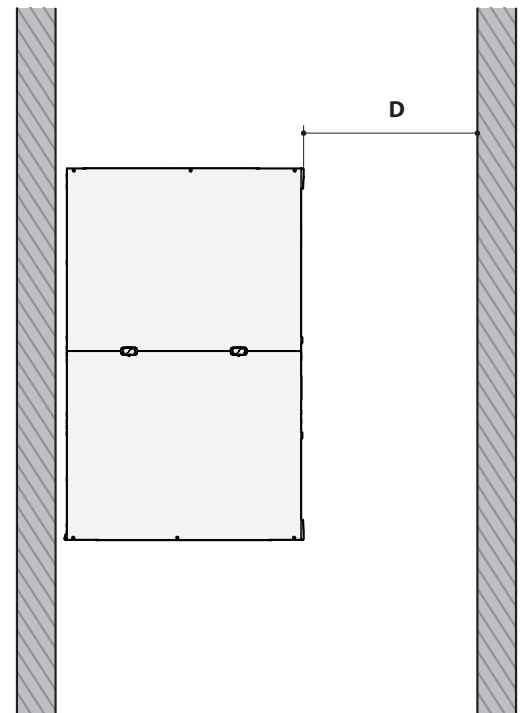
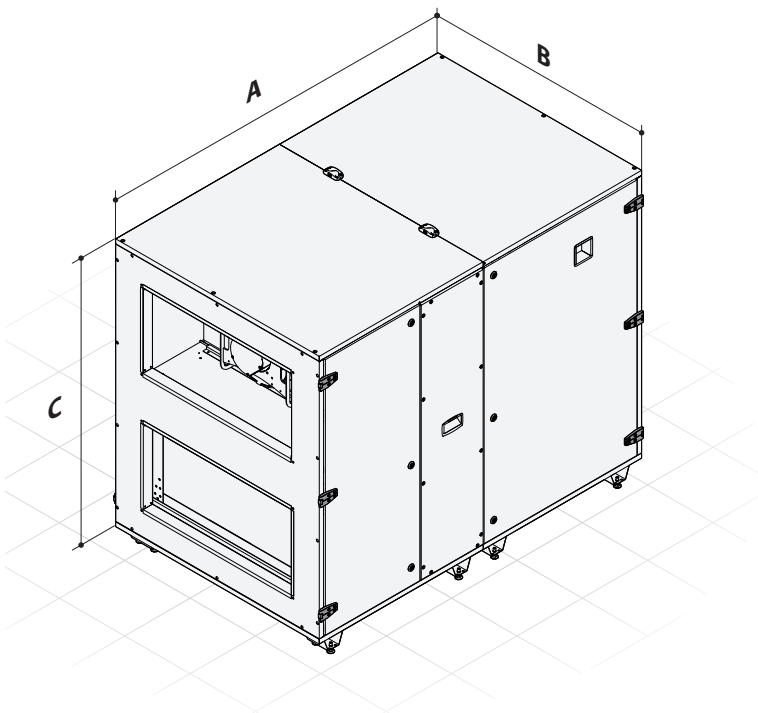

TECHNICAL DATA TABLE	SIZE								
		1	2	3	4	5	6	7	
Nominal air flow rate	m ³ /h	600	1100	1600	2100	2900	3750	5000	
Heat wheel efficiency	%	79,7	78,8	75,6	75,7	74,8	74,5	75,4	
FLA	A	4,3	5,2	5,0	7,8	14,4	14,4	7,4	
FLI	W	0,6	1,1	1,7	1,7	3,4	3,4	4,3	
Electrical connection	-	230V, 1ph						400V, 3ph	

SIZE 1 → 4 COMPACT R

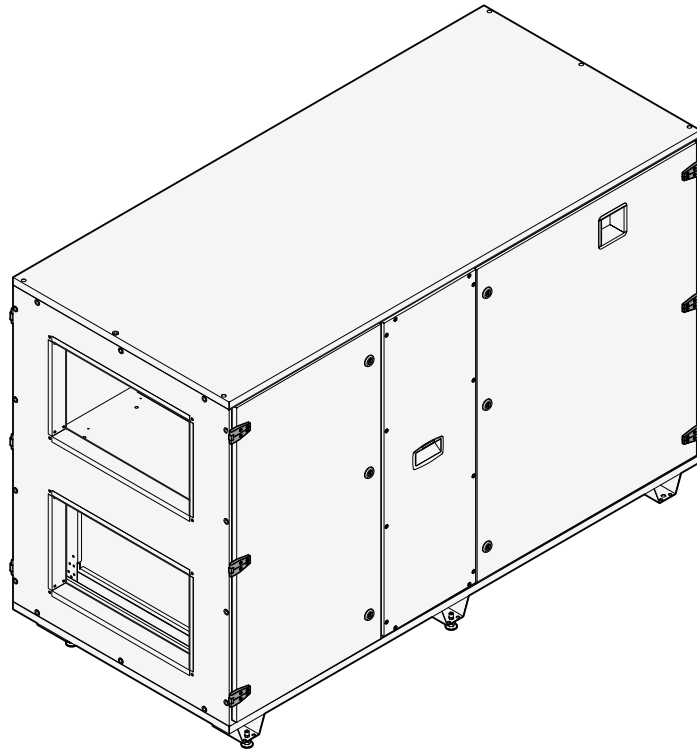

SIZE 5 → 7 COMPACT R

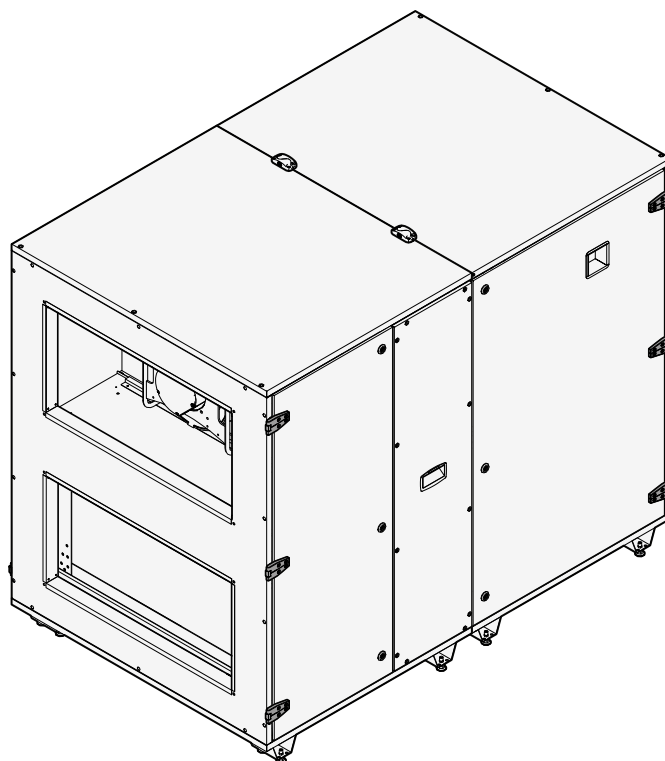

Summary of unit operation

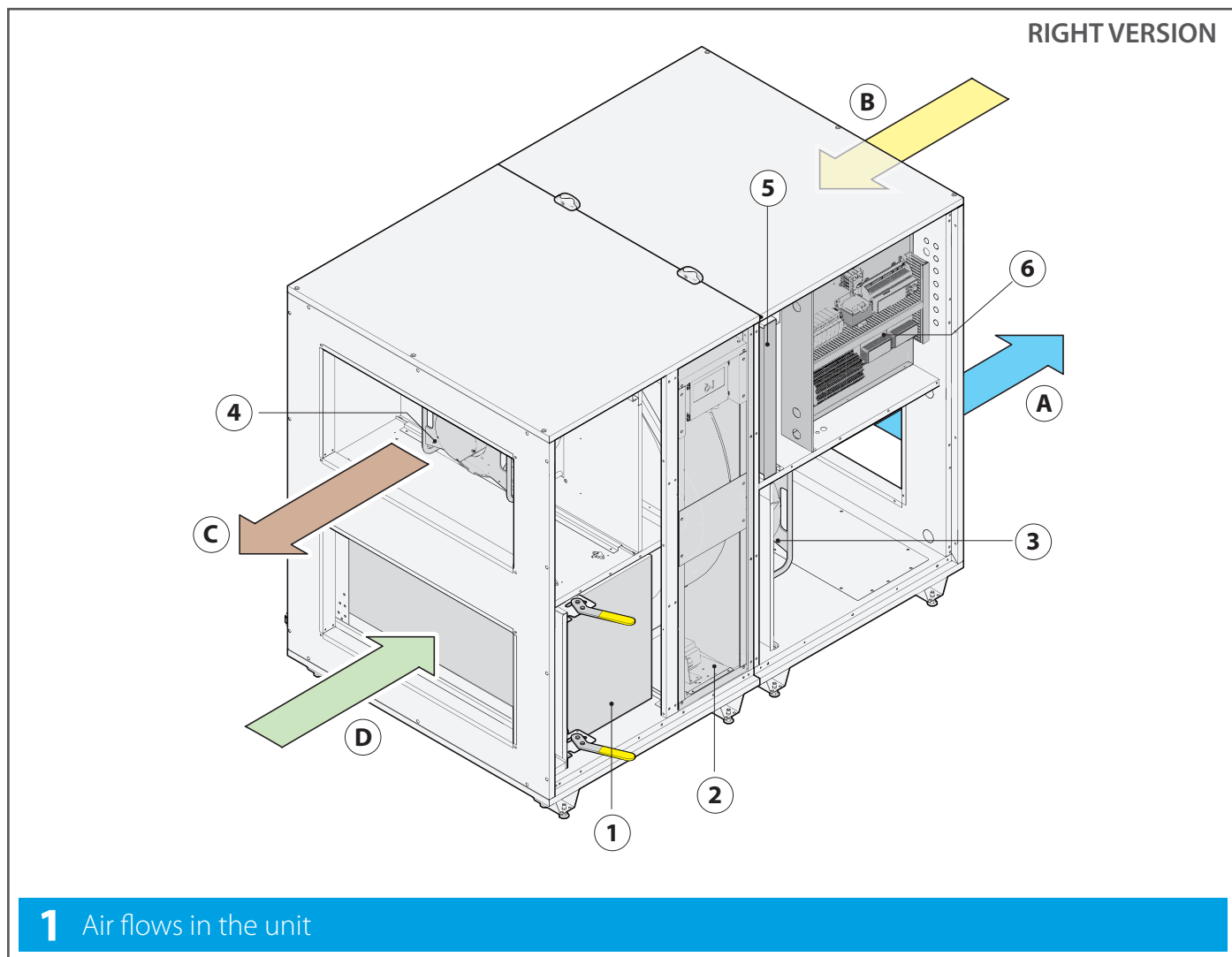

Unit with left orientation

- ① Supply filter
 - ② Heat exchanger
 - ③ Supply fan
 - ④ Return fan
 - ⑤ Return filter
 - ⑥ Control panel
- Ⓐ Supply air
 - Ⓑ Return
 - Ⓒ Exhaust air
 - Ⓓ Fresh air

Unit with right orientation

- ① Supply filter
 - ② Heat exchanger
 - ③ Supply fan
 - ④ Return fan
 - ⑤ Return filter
 - ⑥ Control panel
- Ⓐ Supply air
 - Ⓑ Return
 - Ⓒ Exhaust air
 - Ⓓ Fresh air

Pos.	Component name	Construction material
1	Filter	galvanised steel frame, synthetic filter unit
2	Heatwheel	Condensation/sorption
3	Fan motor assembly	steel frame, composite board impeller
4	Fan motor assembly	steel frame, composite board impeller
5	Filter	galvanised steel frame, synthetic filter unit

3 Receipt of the boxes



Handle the equipment following the Manufacturer's instructions on the packaging and in this manual. Always use personal protective equipment.

The means and method of transport must be chosen by the transport operator according to the type, weight and size of the unit. If necessary, draw up a "safety plan" to guarantee the safety of the people directly involved.



Upon receipt of the unit check the integrity of the packaging and the amount of parcels sent:

A) There is visible damage/one or more cartons is missing: **do not** install, but **promptly** notify the Manufacturer and the carrier that made the return.

Alternatively you can accept the shipment "subject to verification": this will make it possible to open the cartons and check if the internal components are indeed damaged. In the latter case, as noted previously, **promptly** notify the Manufacturer and the carrier that made the return.

Before opening the cartons, it is recommended to take good quality pictures to document the damage.

B) There is NO visible damage: move the unit to the site of installation.

4 Transport



 Packages can be handled with a pallet truck of suitable capacity or with a forklift. The choice of the most suitable means and method lies with the operator.

 The operating area must be perfectly free from objects or people not involved in the transport.

 If transport is done using a pallet truck make sure it is suitable for the weight and size of the unit. Insert the forks into the points provided for handling (usually in a central position) so as to keep the centre of gravity of the load in balance. Move the equipment carefully, avoiding sudden movements.

 Sizes 5 - 6 - 7. After separating the unit from the pallet, it is mandatory to fork the unit from the short side when moving it as a whole.

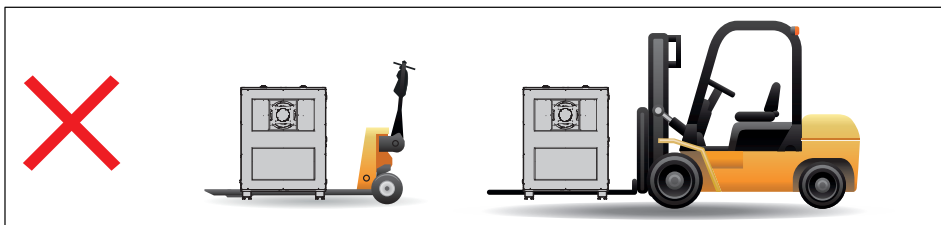
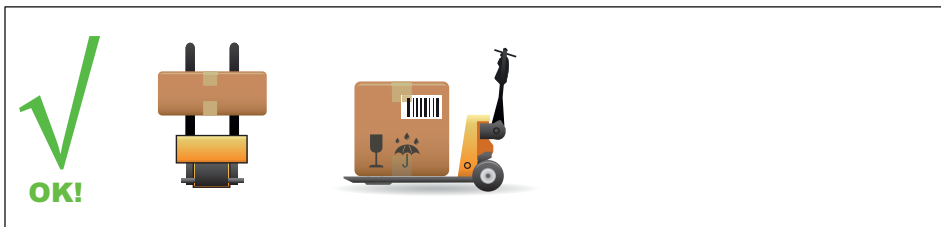

Division of sections (for sizes 5 → 7)

If it is necessary to move the unit in confined spaces, for sizes 5 → 7 it is possible to separate the sections to reduce the overall dimensions, following the instructions below.

2 Division of sections

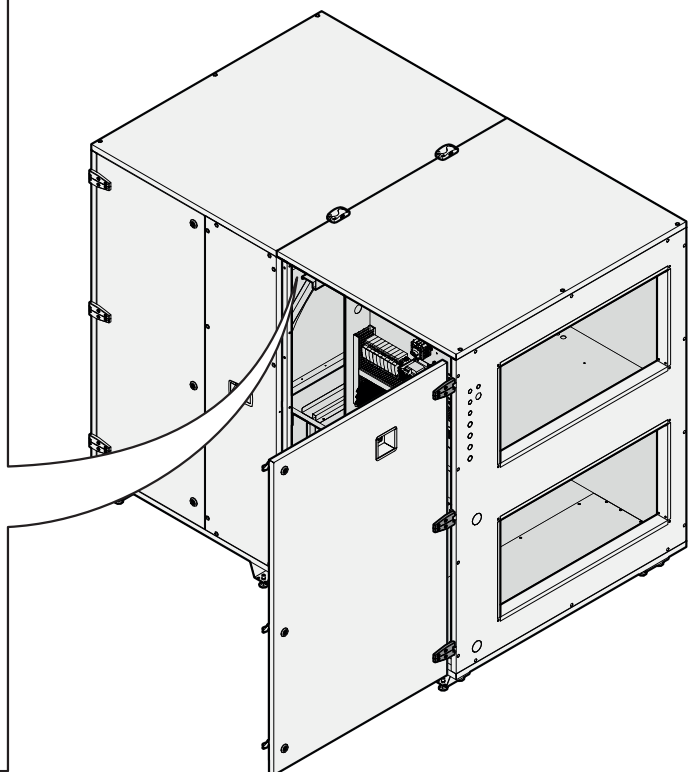
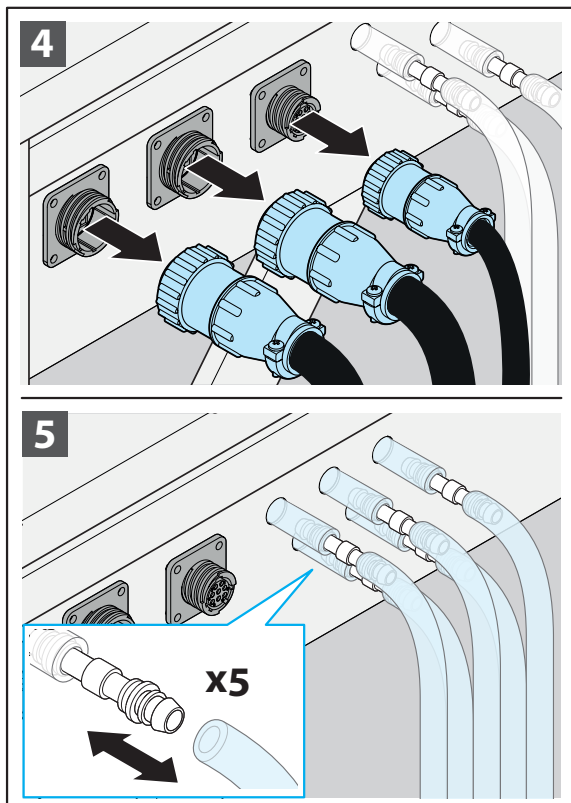
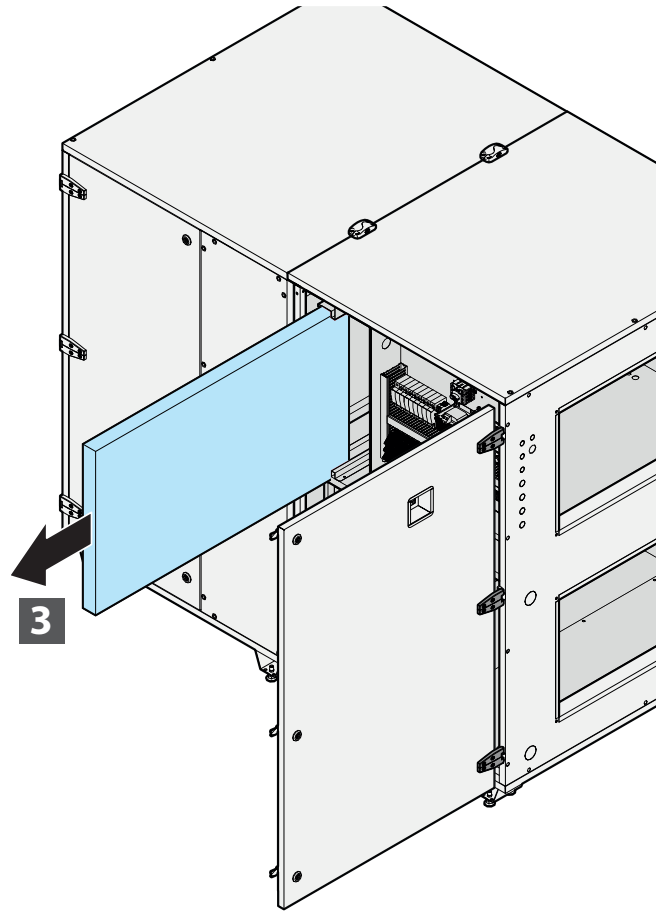
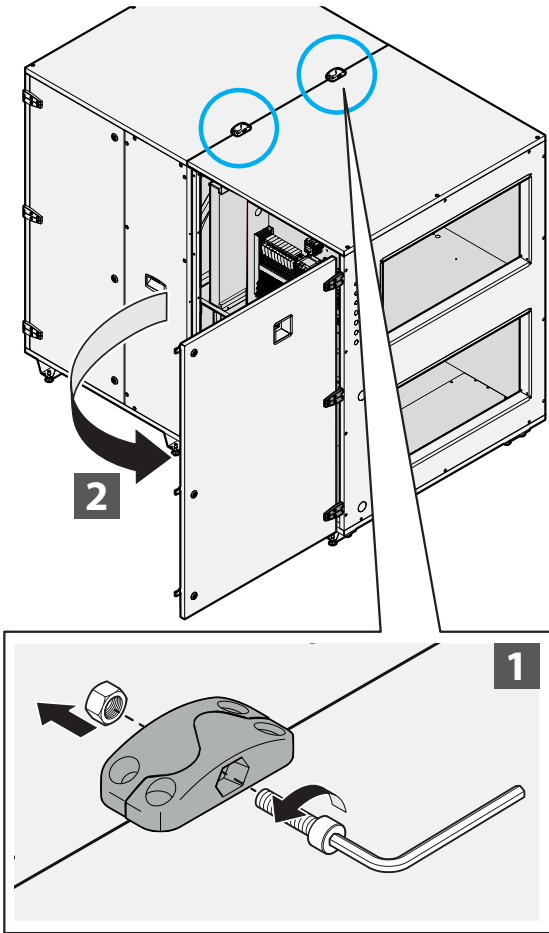

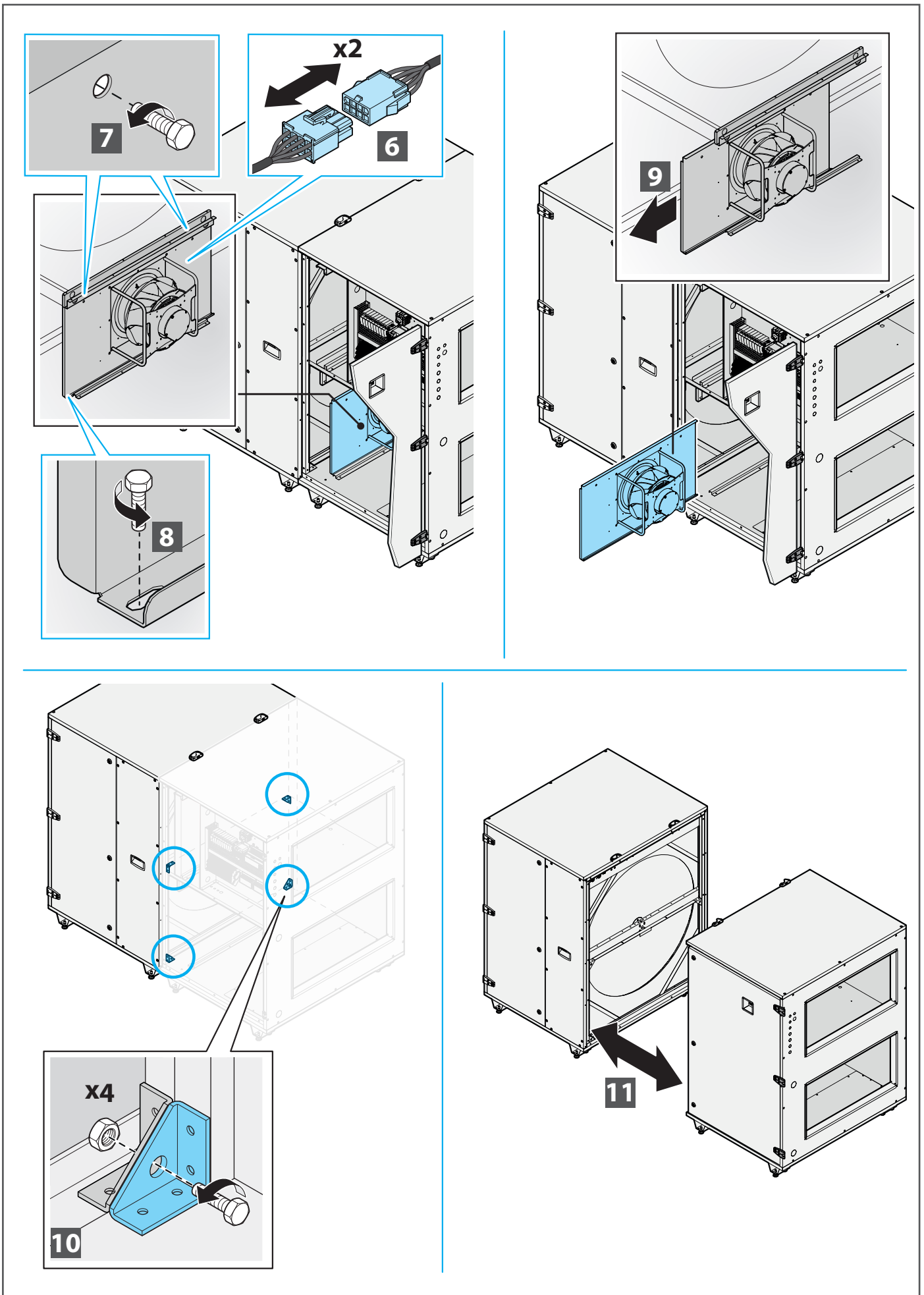

After positioning the sections, join them together following the instructions in the reverse order

5 Unpacking and integrity check



We recommend the equipment be unpacked after moving it to its installation location and only when it is to be installed. This operation must be performed using personal protection equipment (i.e., gloves, safety shoes, etc.).



Do not leave the packing unattended: it is potentially harmful to children and animals (suffocation hazard).



Some packing materials must be kept for future use (wooden crates, pallets, etc.), while those that cannot be reused (i.e., polystyrene, strapping, etc.) must be disposed of in compliance with the regulations in force in the country of installation: this will protect the environment!

After unpacking

After unpacking, check the received contents:

- Ambient thermostat
- Installation and maintenance manual (IOM)
- Wiring diagram
- Declaration of conformity

Check therefore that you have received all the components and that they are undamaged
In case of damaged or missing parts.

- **do not move, install or repair** damaged components and the unit in general;
- **take quality photos** to document the damage;
- **find the serial number plate** on the unit and note the unit serial number;
- immediately **notify** the carrier that delivered the unit;
- **promptly** contact the Manufacturer (keep on hand the serial number of your unit).



Please note that complaints or claims of damage reported after 10 days of receipt of the unit cannot be accepted.

DAIKIN

AHU Codifica / Product number: **D** ARB03LAMNCBT00 POS Code: A83665

Matricola / Serial number: **I** 18C0144 Data / Date: **E** 5/2026 Peso / Weight: **C** 235

PORTATA ARIA / AIR FLOW **B**

Mandata / Supply Fan: **F** 1800 m³/h Ripresa / Return Fan: **G** 1800 m³/h

Corrente / Current: **H** 4.4 A Tensione / Voltage: 230V/1Ph/50Hz

MESSA IN FUNZIONE
All'avviamento consultare il manuale operativo e controllare:
1) senso di rotazione del ventilatore
2) l'assorbimento del motore, il quale non deve superare il valore di targa sopraindicato

START UP
Before the start up read carefully the operating instruction manual and check:
1) fan rotation direction
2) the current input must not exceed the value mentioned on the above tag

A DAIKIN APPLIED EUROPE S.p.A
Via Piani di Santa Maria, 72 00040 Ariccia - (ROMA) IT
MADE IN ITALY

- A:** Manufacturer's name and data
- B:** CE markings
- C:** Unit weight
- D:** Code and POS
- E:** Date of manufacture
- F:** Supply airflow rate
- G:** Return airflow rate
- H:** Electrical specifications (frequency, number of phases, absorption in plate conditions)
- I:** Unit serial number

MANUFACTURER INFORMATION:

DAIKIN APPLIED EUROPE S.P.A.

Via Piani di Santa Maria, 72 - 00040 Ariccia (Roma) - Italy

Tel: (+39) 06 93 73 11 - Fax: (+39) 06 93 74 014

<http://www.daikinapplied.eu>

Product nomenclature

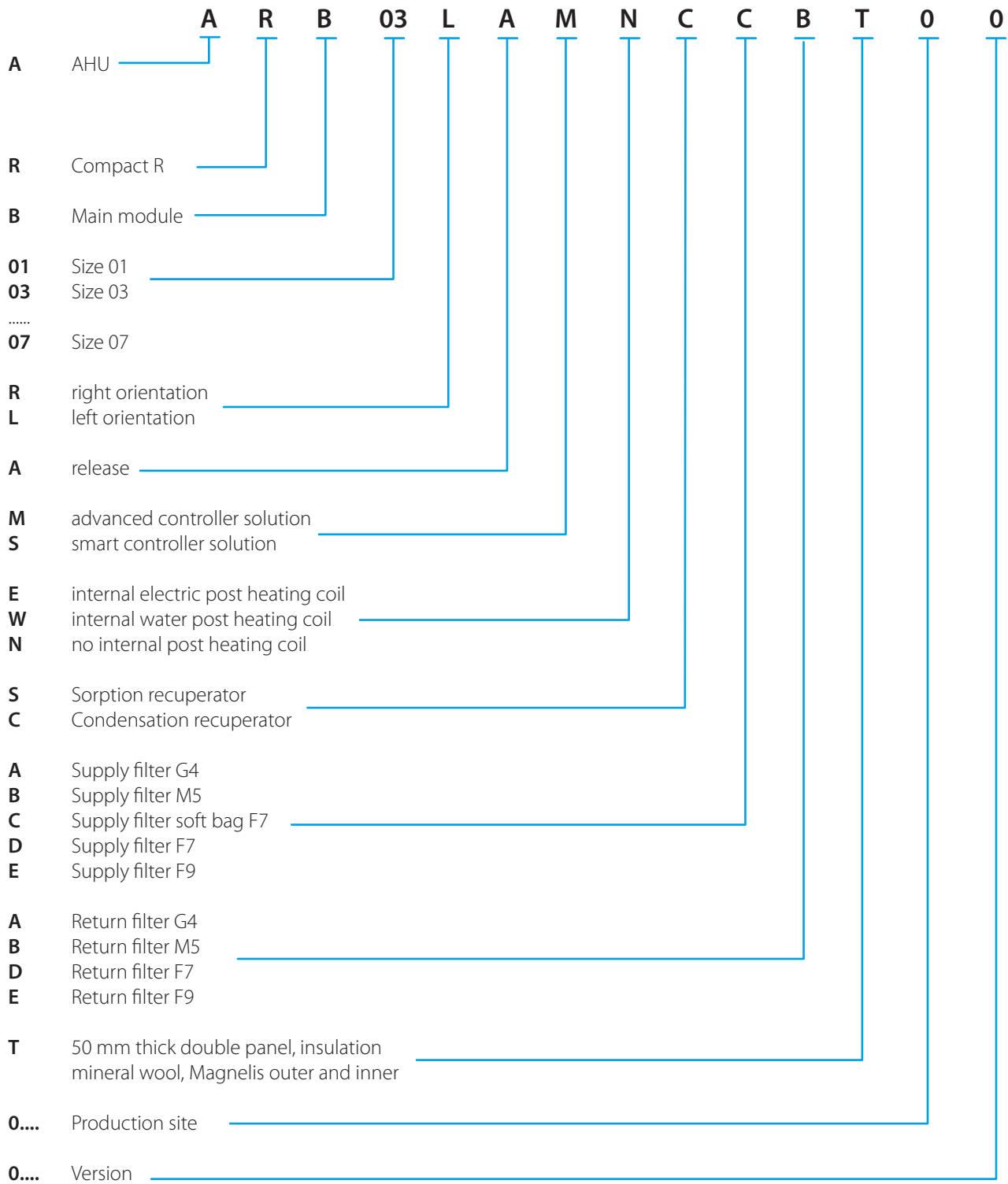

Compact R will be produced according to customer needs.

The standard version is defined by the 7 digits ARB02 (L)A that uniquely identifies a right/left unit, condensation heat wheel exchanger, double 50mm panel, with Microtech controller, no internal coil, F7 at supply, M5 at return, version 0.

Storage waiting for installation

Waiting for the installation, the components of the unit and the relative documents must be stored in an area that:



If you cannot proceed with the installation straight away, check periodically that the above-mentioned conditions of the storage area are maintained and cover the unit with a canvas.



While waiting for the final installation, always provide an insulating base (e.g., wood blocks) between the floor and the unit itself.

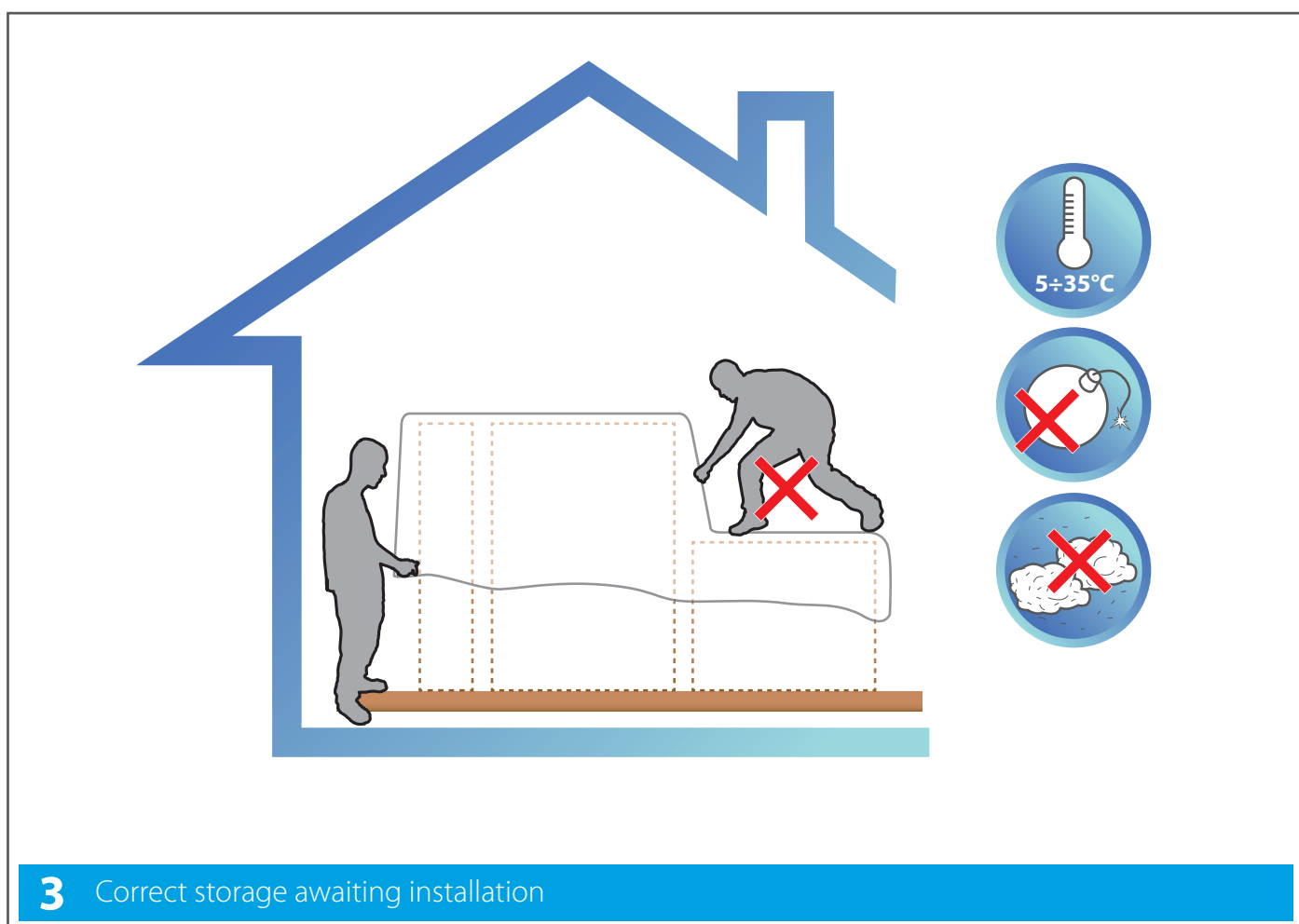

Any movement carried out after unpacking must be done with the doors closed. Do not move the units by pulling on the doors, if present, the uprights or other protruding parts that are not an integral part of the structure.



Do not step on the units!

6 Installation



All installation, assembly, electrical connections to the mains and extraordinary maintenance must be performed **only by qualified personnel authorised by the Retailer or Manufacturer**, in compliance with the regulations in force in the country the equipment is to be used and the standards on the systems and safety in the workplace.



During installation, the area must be free from people and objects not used for the assembly.



Before starting, make sure you have all the necessary equipment.

Use only equipment that is in good condition and undamaged.



Installation procedure

Before installation, read the safety instructions on the first pages of this manual. Contact the Manufacturer if any points are unclear or not perfectly understandable. A check mark next to each step will help to confirm complete and proper installation.

<input type="checkbox"/>	Step 1: Make the connections for COMPACT R.....	page 22
<input type="checkbox"/>	Step 2: Perform a trial run.....	page 26
<input type="checkbox"/>	Step 3: Safety signs.....	page 27

After installation store this manual and the assembly sheet that accompanied the unit in a place that is dry and clean. This way it will be accessible to operators in the future who need to consult it. Do not remove, tear out or write on any part of this manual besides the space set aside for notes:

Step 1: Make the connections for **COMPACT R**

To operate the unit requires:

- An electrical connection.
- Drain.
- A connection to the aeraulic circuit (air ducts).

Electrical connection

For the **power supply** it is necessary to connect the unit to an electrical panel in compliance with current regulations.



Always refer to the wiring diagram that is specific to the unit that you bought (it was shipped with the unit). If it is not on the unit or has been lost, contact the salesperson of reference who will send a copy (specify the unit's serial number).

Before connecting the electrical panel, make sure that:

- The voltage and frequency of the power supply correspond to the parameters of the unit.
- The electrical system being connected has sufficient capacity to supply the nominal electric power of the unit to be installed and meets current regulations.





The electrical connection must be:

- Performed by qualified personnel after cutting off the facility's power supply.
- Performed in a fixed and permanent manner, without intermediate splices, in accordance with the regulations of the country of installation.
- The power supply is sufficient for the unit (see technical specifications).
- supplied with an effective, compliant earth connection; where there are multiple units, each unit must be connected to the earth or they must be joined using metal clamps;
- Preferably situated in a dedicated room, **locked** and protected from atmospheric agents. If there is also a key switch, the key must be removed when cutting the power supply and returned to its position only after finishing service operations.
- install a **16A circuit breaker** system or a system suited to the unit absorption



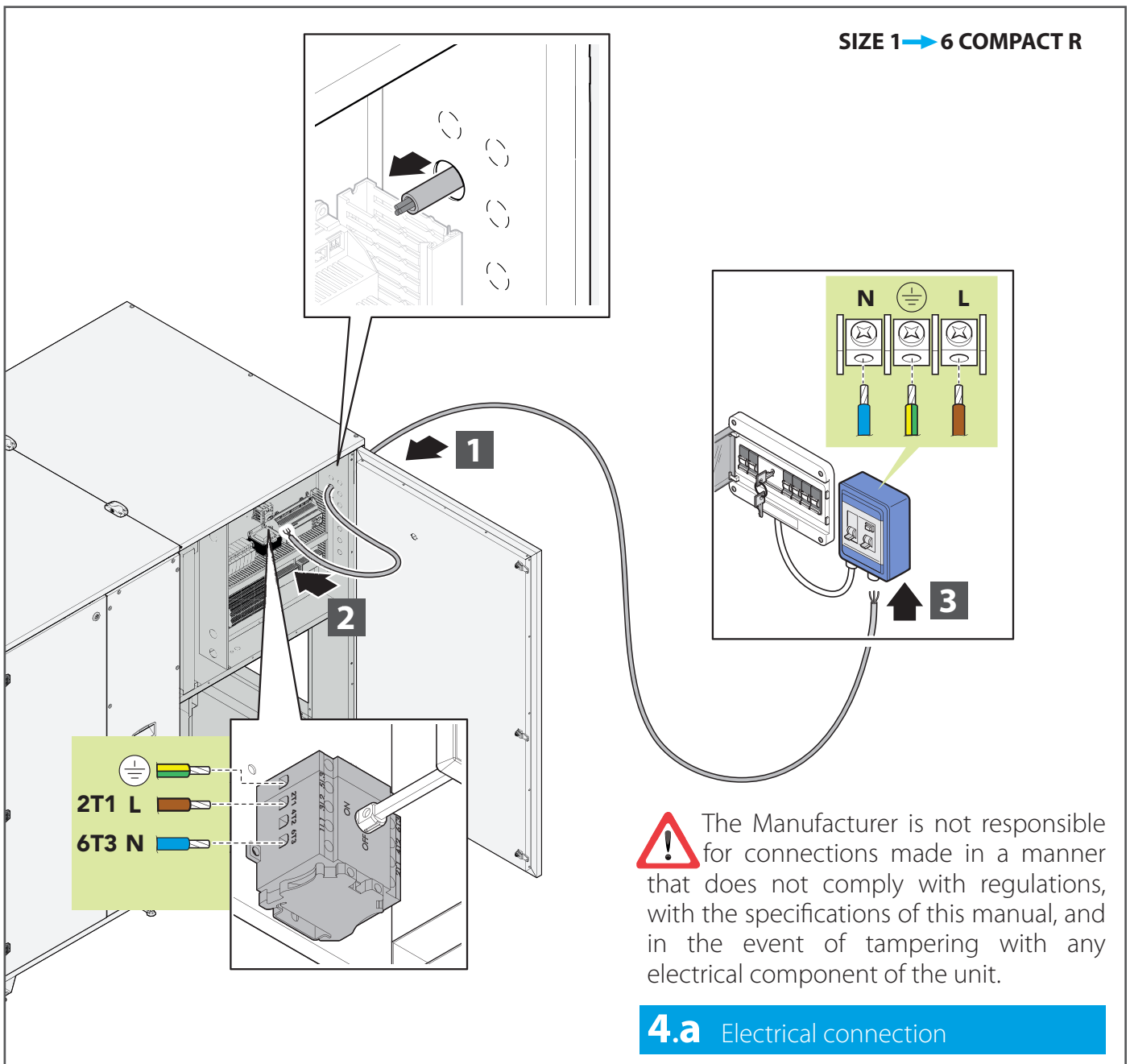

During installation and maintenance, make sure that **no other person** besides the one who is working has access to the electrical cabinets or switches.

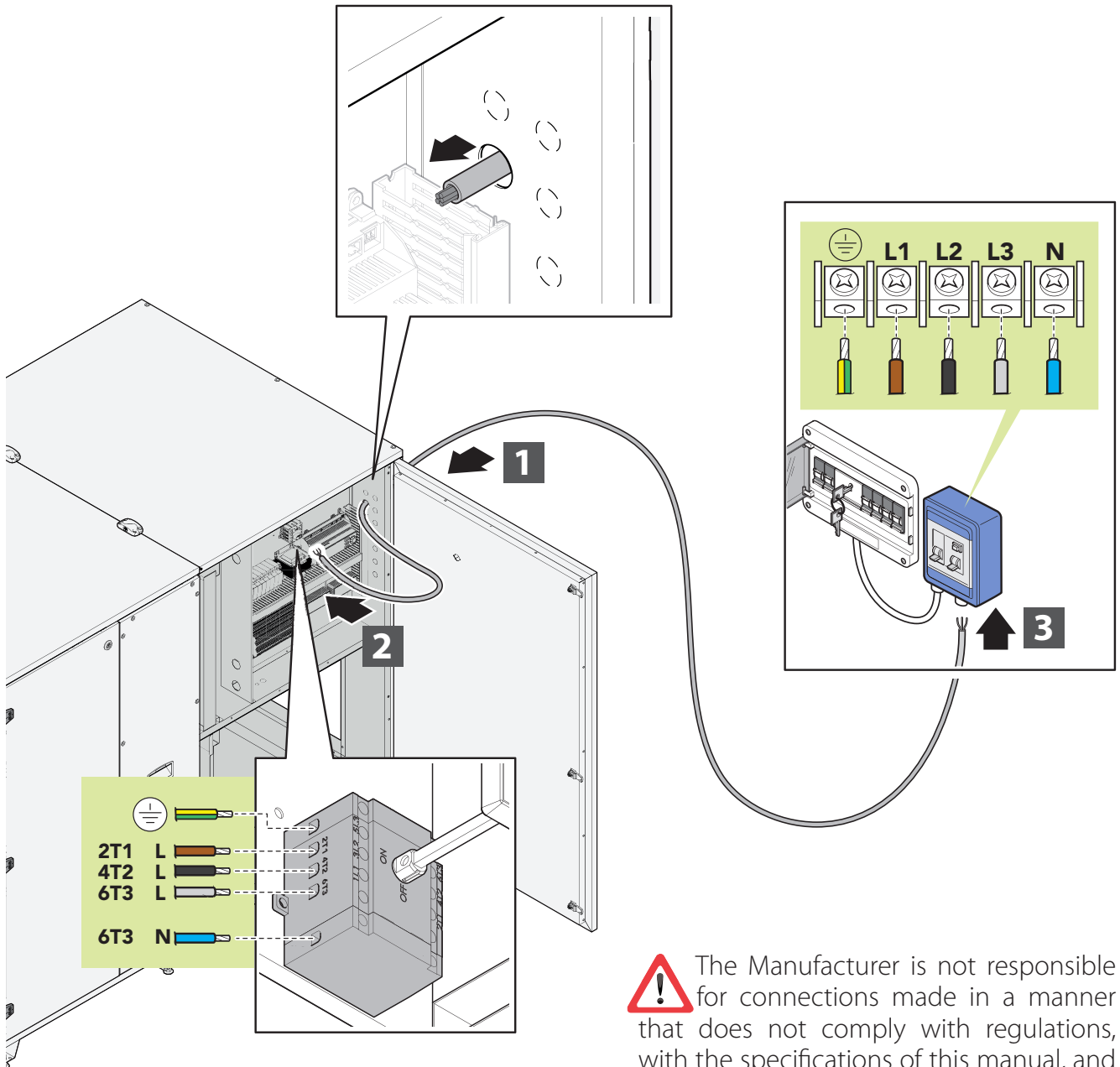

 The Manufacturer is not responsible for connections made in a manner that does not comply with regulations, with the specifications of this manual, and in the event of tampering with any electrical component of the unit.

4.a Electrical connection



 The Manufacturer is not responsible for connections made in a manner that does not comply with regulations, with the specifications of this manual, and in the event of tampering with any electrical component of the unit.

4.b Electrical connection



The actual supply voltage of the users **must not deviate more than 10%** from the normal voltage expected. Higher voltage differences cause damage to users and to the electrical system, malfunctioning of fans, noise. It is therefore essential to check the alignment of the actual voltage values with the nominal values.

After connecting, make sure that:

- The ground connection is sufficient (using the appropriate tool). An incorrect connection, ineffective and lacking the grounding circuit, is contrary to safety regulations and is a source of danger and can damage the components of the unit.
- the connections are correct and the current consumption of the motor is lower than indicated on the nameplate.

Ambient thermostat connection (optional)

A room thermostat is not supplied with the unit (optional), which must be connected as shown in the figure

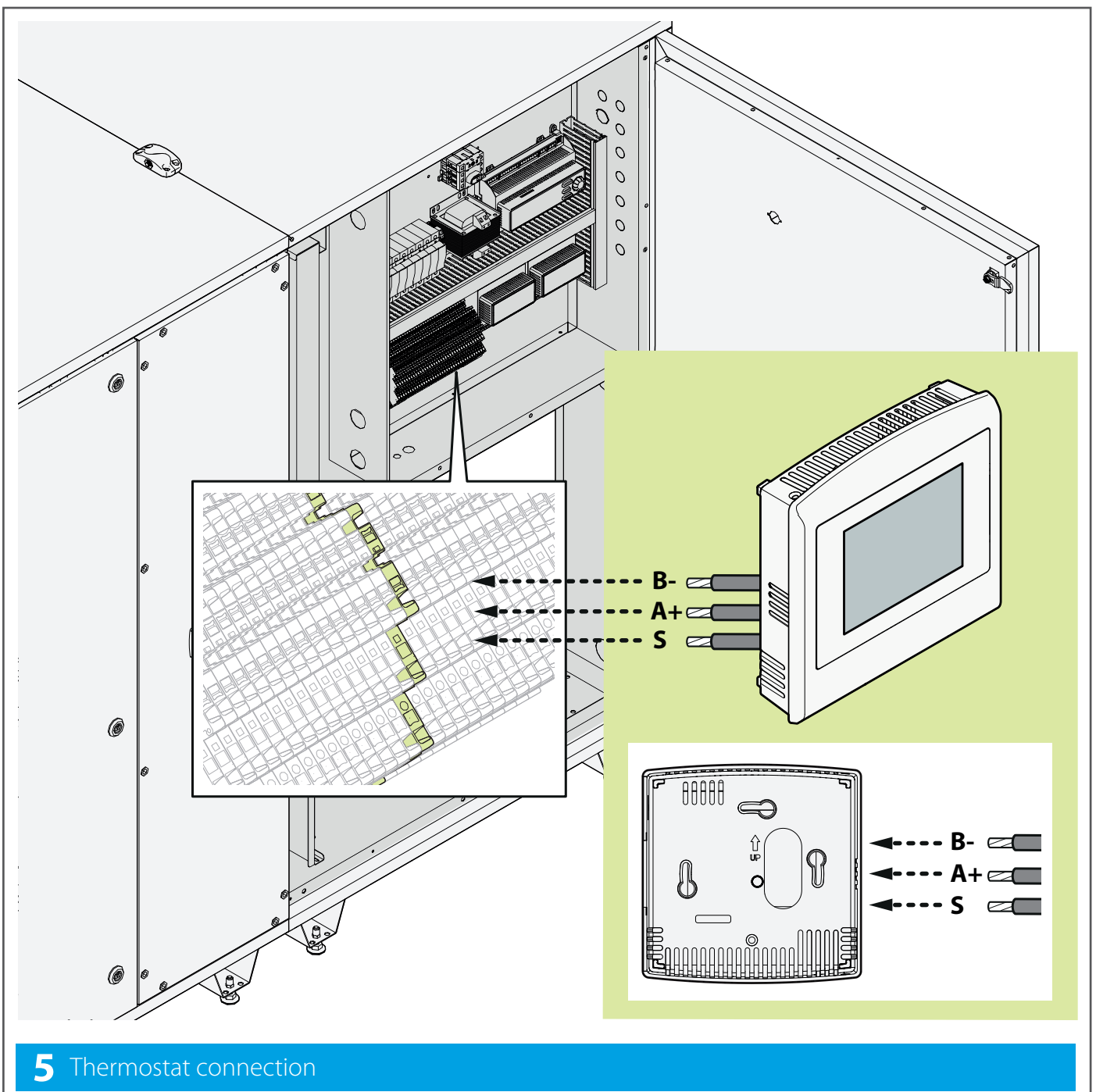

5 Thermostat connection

Step 2: Perform a trial run

To commission the unit it is necessary (tick "✓" the operations completed):

	Check accurate fluid inlet and output pipe connections to the exchange coils (if applicable)
	Check that there is a suitable siphon for all the water being drained.
	Place a shock absorbing joint between the unit and ducts (optional);
	Check unit integrity;
	Check the integrity of the anti-vibration supports and the various accessories.
	Remove extraneous materials (e.g., assembly sheets, tools, clips, etc.) and dirt (footprints, dust, etc.) from inside the sections.

Step 3: Safety signs

The unit is supplied with the electricity-specific signs on the access doors to the fan sections.

The buyer must position other appropriate signs in the work area:

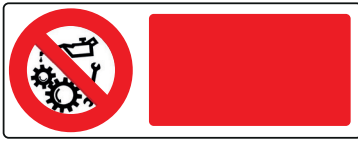

DO NOT REMOVE THE PROTECTIONS AND SAFETY DEVICES



DO NOT REPAIR - OIL - ADJUST - CLEAN MOVING PARTS

In addition, the space where the unit is positioned must be integrated into the general signage, specific to the characteristics of the area and workplaces:

noise - movement - dangerous areas - escape route, etc.

PERSONAL PROTECTIVE EQUIPMENT

Personal protective equipment should be used when operating the unit, suitable for use in accordance with company criteria and rules.

During unit maintenance, other preventive measures are suggested in addition to the above: safety shoes, gloves, suitable clothing, always compatible with the use and according to company guidelines.

TRAINING

It is the responsibility of the unit buyer/user to provide adequate instruction and training to unit operators.

OPTIONAL

In agreed cases, additional training may be provided through the one-on-one instruction of operators by the Manufacturer's technical staff.

7 Commissioning

Please refer to OM, D-EOMAH04002-26_00.

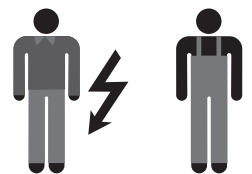

8 Maintenance

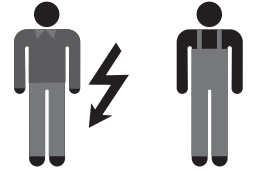

Safety precautions for maintenance



Ordinary and extraordinary maintenance must be carried out **solely by the operator assigned to perform maintenance** (mechanical and electrical maintenance staff) according to the regulations in force in the country of use and respecting the laws regarding systems and work safety. Remember that, by operator assigned to perform maintenance is meant the person who can work on the unit to perform ordinary and extraordinary maintenance, repairs and fine tuning. This person must be an expert operator, properly instructed and trained, given the risks involved in such operations.



Before performing any ordinary and extraordinary maintenance, the unit **must always be stopped (by disconnecting from the mains)** and **the EMERGENCY button engaged**. The switch must have a key that must be removed and held by the operator who will perform the operations until the end of the maintenance itself.



It is absolutely prohibited to remove any protections from moving parts and unit protection devices with the unit connected to the mains or operational. Adjustments made with safety devices disengaged must be performed **by a single person**, expert and authorised, and during this activity it is necessary to prevent access to the area of the unit by other people. Upon completing the adjustments with safety devices disengaged, the protections must be re-engaged as soon as possible.



During maintenance, the operating space in front of the unit, as indicated in the table on page 12, must be free of obstacles, clean and well lit. Unauthorised persons are prohibited from entering and remaining in this space.



Use personal protective clothing (safety shoes, safety glasses, gloves, etc.) compliant with regulations.



Before carrying out repairs or other work on the unit, **always declare out loud** your intentions to other operators who are located in the unit area and make sure that they have heard and understood the warning.



Ordinary maintenance

Proper maintenance of the systems maintains efficiency (reducing costs) and consistent performance over time, and increase the usable life of the equipment.

ACTIVITY	FREQUENCY			
	A	B	C	D
General cleaning of the unit.		√		
Check and eventual disassembly and washing of filters.				√
Replacing the filters (when they have deteriorated).	in case of alarm			
Clean the finned surfaces of the heat exchange coils (if provided) with a jet of compressed air and soft brush.	√			
Clean the exchange surfaces of of heat recuperators with a jet of compressed air and soft brush.	√			
Empty and clean the condensate collection basins if applicable.		√		
Visual inspection for corrosion, limescale, release of fibrous substances, any damage, abnormal vibrations, etc. (if possible, it is advisable to extract the components for a more thorough inspection).			√	
Check condensate drain and cleaning of siphons, if there is a coil kit.		√		
Check the status of anti-vibration connections.	√			
Cleaning of the heat exchanger		√		
Check the belt tension	√			
Check the integrity of the cleaning septum	√			
Check tightness of screws and bolts in the fan section.	√			
Check the impeller and various devices, with removal of any buildup.	√			
Check the integrity of piping connected to pressure gauges and pressure switches.		√		
Check the ground connection.		√		
Power connection terminal torque	√			

A: every year

B: every six months

C: every three months

D: every month

General information on cleaning procedures



Read the safety instructions at the beginning of this manual and page. 28



You should consult with your supplier of chemical products to choose the most suitable for cleaning the unit components.



For the cleaning method refer to the instructions of the detergent manufacturer and carefully read the safety data sheet (SDS).

As general guidelines, refer to the following rules:

- Always use personal protection (safety shoes, safety glasses, gloves, etc.).
- Use mild products (pH between 8 and 9) for washing and disinfecting, in normal concentrations. Detergents must not be toxic, corrosive, flammable or abrasive.
- Use a soft cloth or bristle brushes that do not damage the stainless steel surfaces.
- If you use water jets, the pressure should be less than 1.5 bar and the temperature must not exceed 60°C.
- To clean components like motors, damper motors, bearings, Pitot tubes, filters and electronic sensors (if applicable), do not spray water directly on them.
- After cleaning make sure that you have not damaged the electrical parts and the seals.
- Cleaning operations should not involve the lubricated parts, like rotation shafts, because this could affect their good operation and create problems with durability.
- For the cleaning of finned components or dampers use an industrial vacuum cleaner and/or a compressor. Attention, the compressed air flow must run opposite to the direction of airflow through the unit.
- To clean plastic components such as tapping points, grommets, cable glands, connecting pipes and clicks, use a cloth soaked in alcohol. We recommend carrying out the operation during the general cleaning of the unit and when replacing the filters. In case of the cleaning with soaked cloth it's not enough, please proceed to replace the plastic components.

Cleaning lamellar components

Remove the dust and fibres with a soft bristle brush or a vacuum cleaner.



Be careful when cleaning with compressed air because the exchanger package can be damaged. CLEANING with pressure jets is allowed if the maximum water pressure is 3 bar and a flat nozzle is used (40° - WEG 40/04 type).

Oils, solvents, etc. can be removed with water or hot grease solvents, by washing or immersion. Periodically clean the condensate drain tray and fill the drain siphon with water.

Vents

Periodically check that there are no new sources of contamination near the air intake. Each component must be checked periodically for the presence of contamination, damage and corrosion. The seal can be protected with glycerine-based lubricants or replaced with a new one, if worn.

Fans

The fans can be cleaned with compressed air or by brushing them with soap and water or with a mild detergent.

Finish the cleaning by rotating the fan by hand to verify the absence of abnormal noises.

Fan assemblies are easily removable from the side, as shown in the picture below:

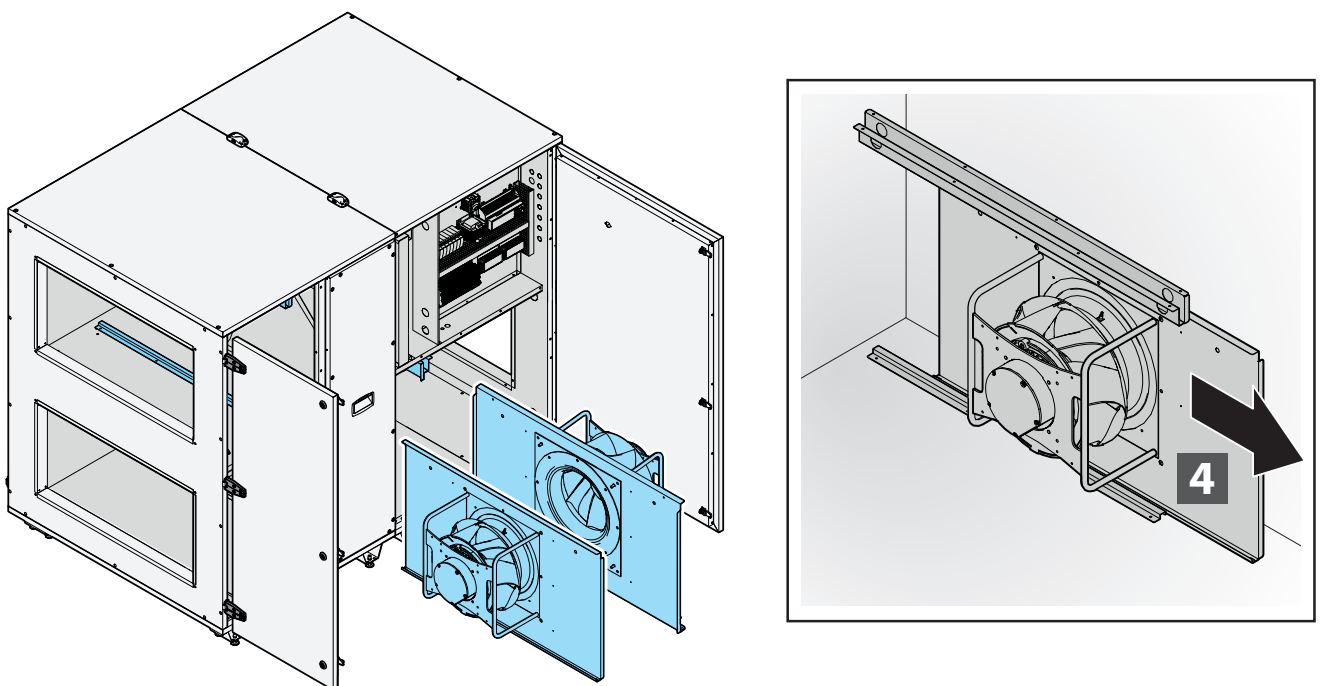
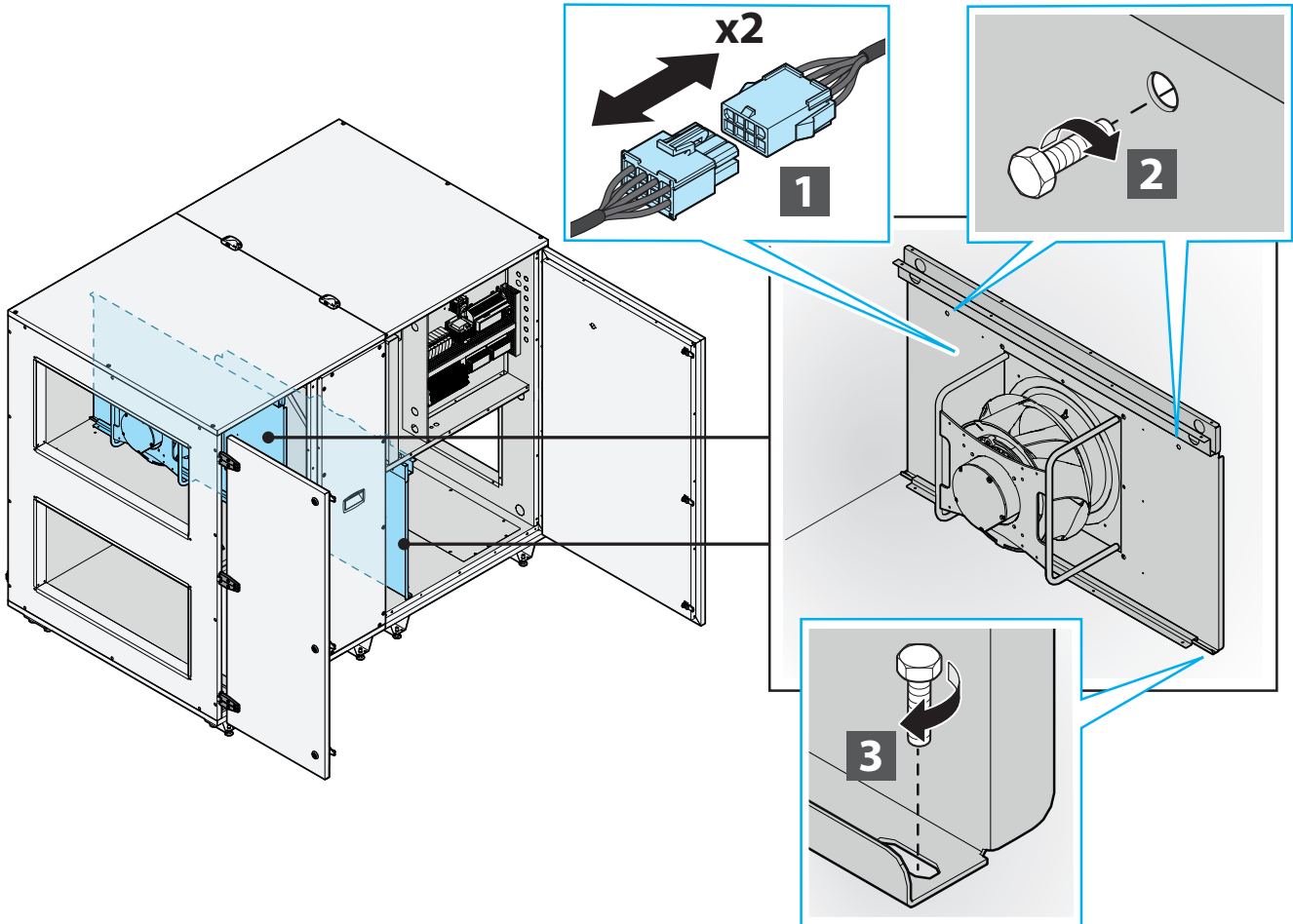

Cleaning filters



The unit must NOT be running when the filters are removed to avoid drawing in outside air that might be contaminated.

Filters need to be cleaned often and carefully. Usually, the compact filters (G4) can be cleaned **two or three times** by vacuuming them with a vacuum cleaner, or by blowing them with compressed air before replacing them. For replacement, refer to the control system signalling.

Correct filter and pre-filter installation (in the event of replacement)

Remove the old filters (see previous chapter), extract the new filters from the packaging (in which they are supplied to avoid deterioration during transport and stay on site), insert them in the special containment section, paying attention to their correct positioning.



Remove the filters from their packaging only when ready to install them to avoid getting them dirty and contaminating them.



Make sure that the inside of the filter is not contaminated by external agents.

This operation should be carried out about one hour after the first start-up of the unit, the period during which the ducts are cleaned of dust and various debris. Proceeding in this way preserves the filtering sections that cannot be regenerated.

6 Return filter

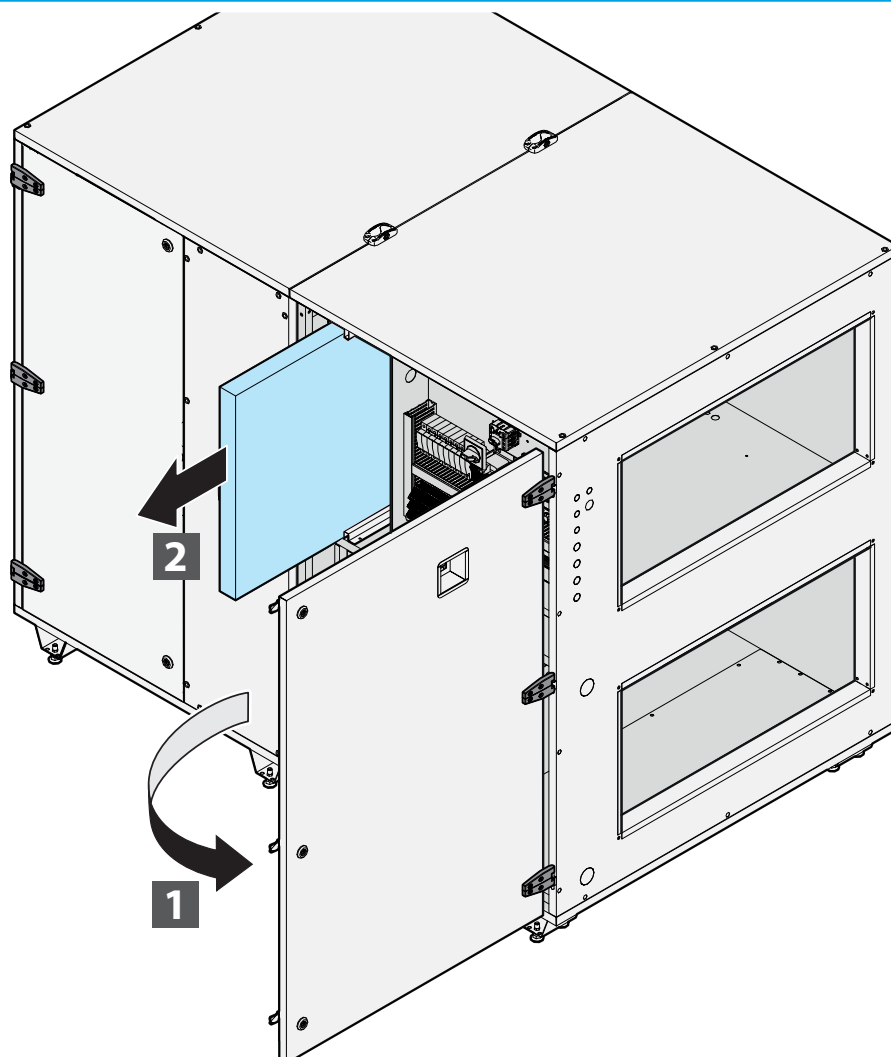

7 Supply filter

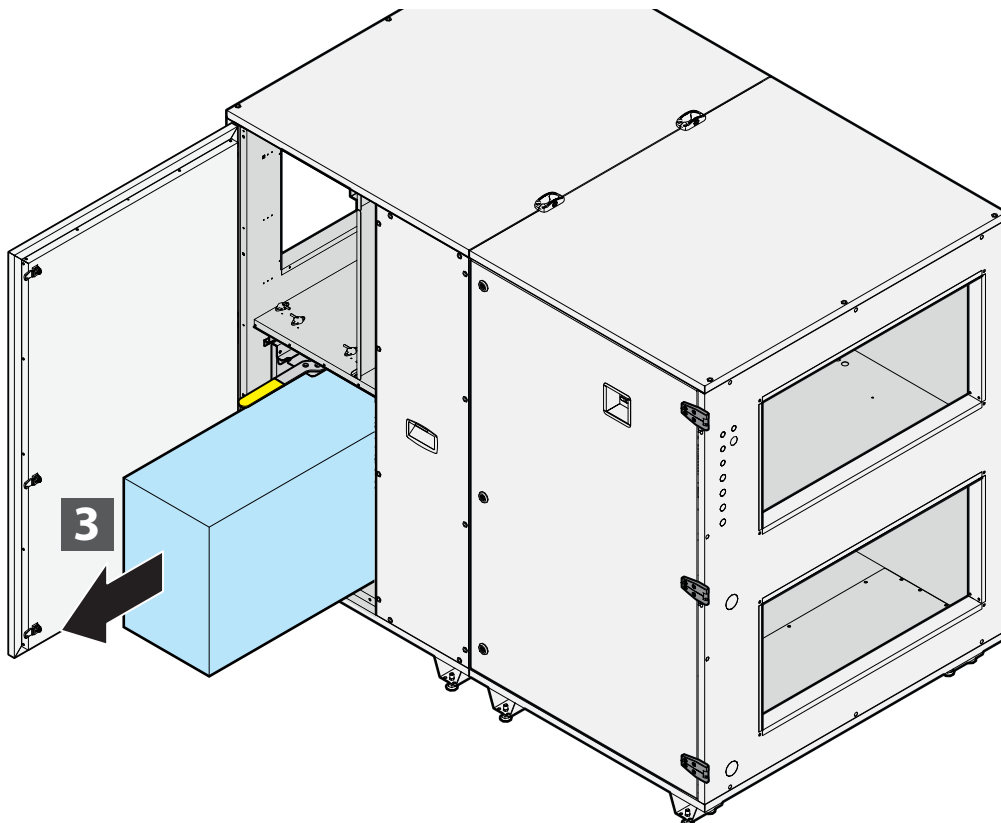
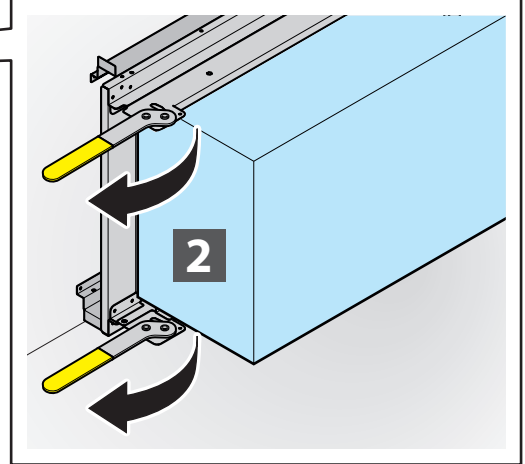
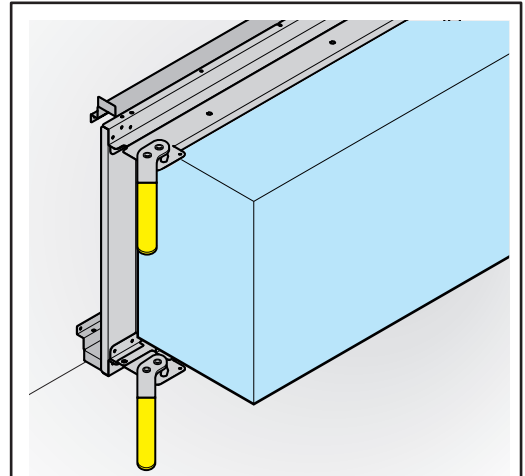
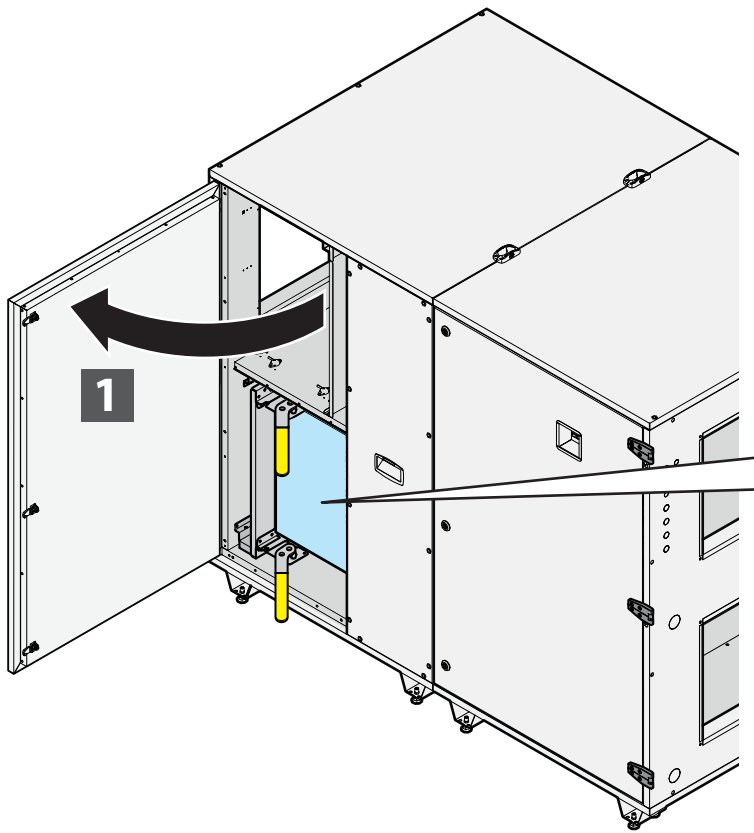

Extraordinary maintenance

One can not predict extraordinary maintenance as it is normally due to effects of wear or fatigue caused by the incorrect operation of the unit.

Replacement of parts



The replacement of parts should be performed by expert personnel:

- Qualified maintenance mechanic
- Qualified maintenance electrician
- Manufacturer technician

The unit is designed to be able to perform all the servicing necessary to maintain good efficiency of the components. However, it sometimes happens that a component fails due to malfunction or wear, so for replacement refer to the executive schematic.

These are the components that may need replacement:

- Filters ▶ see fig. 14
- Recovery ▶ see fig. 14
- fans ▶ see fig. 14

For some of these operations of a general nature we will not enter into detail as these are operations that fall within the abilities and professional expertise of the staff assigned to perform them.

Consumable components - Spare parts

During the operation of the unit there are particular mechanical and electrical components that are most subject to wear. These parts must be monitored in order to carry out their replacement or repair before they cause problems to the correct operation of the unit with consequent downtime (see table on page 38).

Replacement of heatwheel

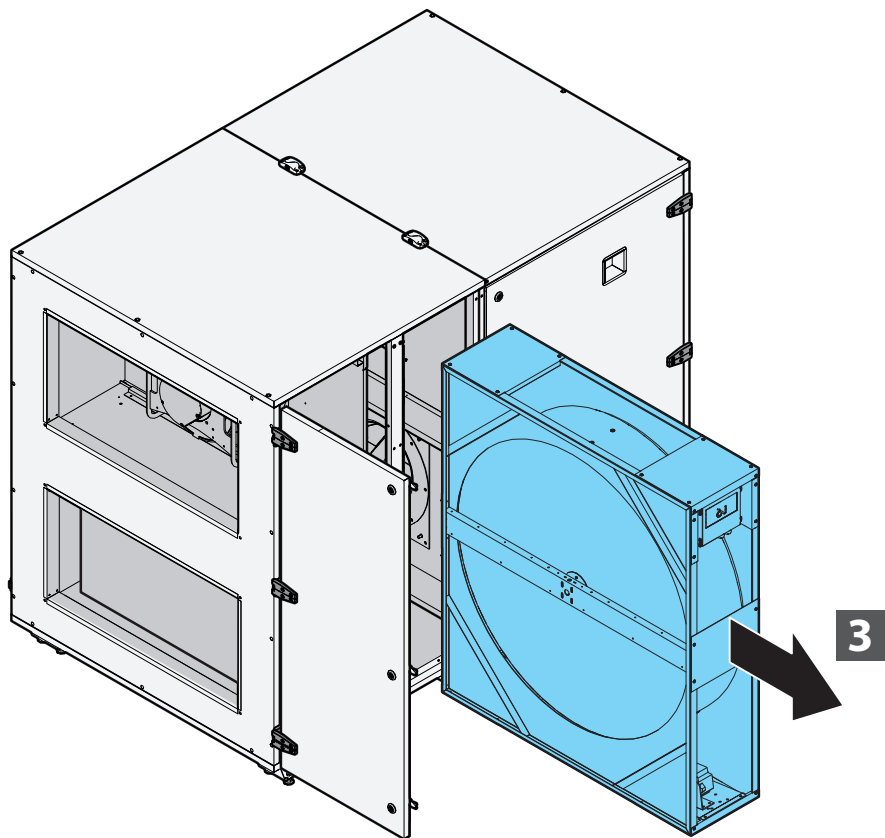
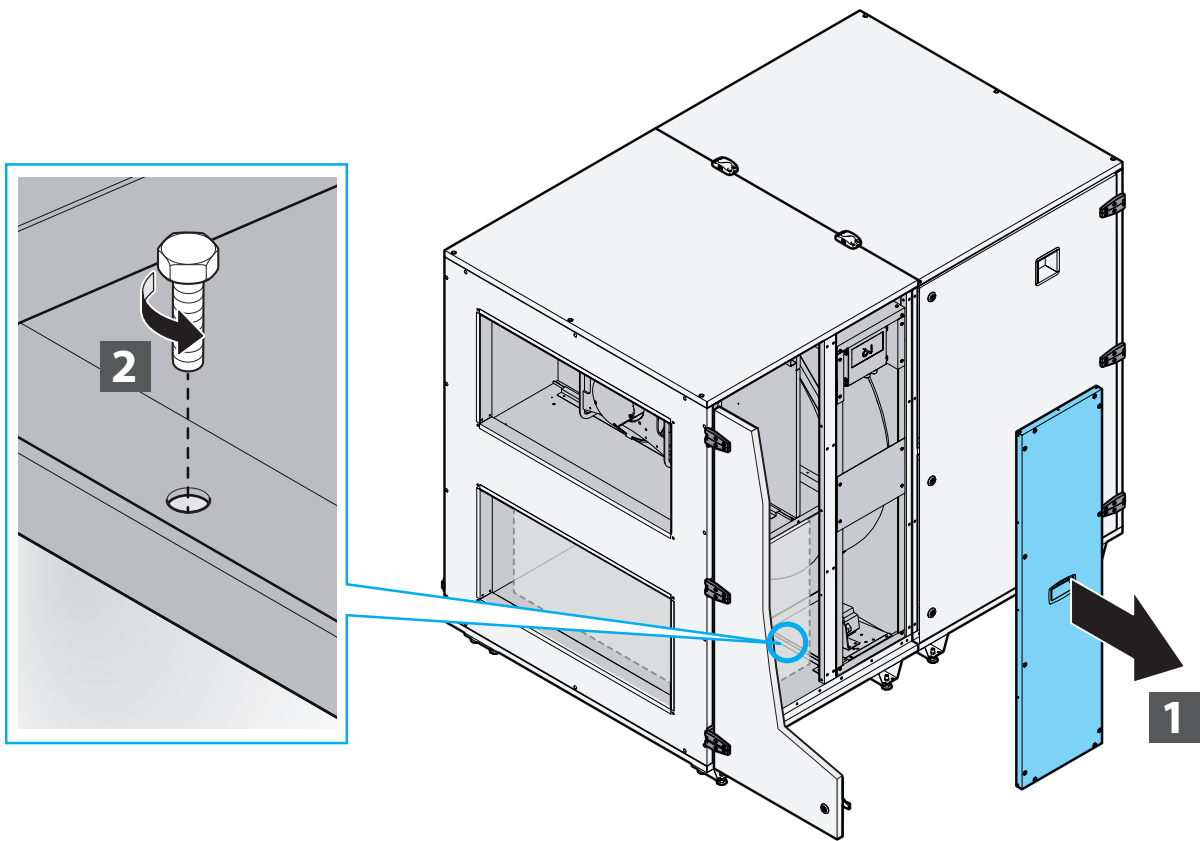

DEFINITION OF WASTE

Waste is any substance and object deriving from human activities or natural cycles that is disposed or destined to be abandoned.

SPECIAL WASTE

Special waste includes:

- Residues from industrial, agricultural, artisanal, commercial and service processes that in quality or quantity are considered different from municipal waste.
- Deteriorated or obsolete unitry and equipment.
- Motor vehicles and their parts that can no longer be used.

HARMFUL TOXIC WASTE

Harmful toxic waste is all waste containing or contaminated by substances listed in the annex to the Italian Presidential Decree 915/52 implementing directives 75/442/EEC, 76/442/EEC, 76/403/EEC, 768/319/EEC. Following are described the types of waste that may be generated during the lifetime of an air handling unit:

- Cell filters from the suction unit.
- Waste oils and greases from lubricating the fan motor assembly.
- Rags or paper soaked with substances used for the cleaning of the various parts of the unit.
- Residues from cleaning the panelling.



Waste from the cell filters are to be handled as special waste or harmful toxic depending on their use, the sector and the environment in which they are used.

Waste and scraps may cause irreparable damage if dispersed in the environment.

ELECTRICAL/ELECTRONIC WASTE

Under art. 13 of Italian Legislative Decree no. 49 of 2014 "Implementation of the WEEE Directive 2012/19/EU on electrical and electronic equipment waste.



The logo with the crossed-out bin specifies that the product has been placed on the market after 13 August 2005 and that at the end of its useful life it should not be disposed of with other waste but rather must be collected separately. All equipment is made from recyclable metallic materials (stainless steel, iron, aluminium, galvanised steel, copper, etc.) in a percentage higher than 90% by weight. Before disposal make the equipment unusable by removing the power cord and closing any devices for closing compartments or cavities (where present). It is necessary to pay attention to the management of this product at the end of its life by reducing its negative impact on the environment and improving the effective use of resources, applying the principles of "he who pollutes pays", prevention, preparation for reuse, recycling and recovery. Remember that the illegal or improper disposal of the product may result in the application of sanctions provided for by current provisions of law.

Disposal in countries of the European Union

The EU Directive on WEEE equipment has been implemented differently by each country, so to dispose of this equipment we suggest contacting local authorities or the dealer to ask for the correct method of disposal.

Diagnostics

General diagnostics

The unit's electrical system includes quality electromechanical components and is therefore extremely durable and reliable over time.

Should there be any malfunctions due to malfunctions of electrical components it will be necessary to act as follows:

- Check the fuses of the power supply for the control circuits and if necessary replace them with fuses having the same specifications.
- Check if the thermal protection switch for the motor has been triggered or if its fuses have blown.

If this has occurred, it may be caused by:

- Motor overload due to mechanical problems. They need to be solved.
- Incorrect supply voltage. Verify the protection trip threshold.
- Malfunction and/or short circuits in the motor. Identify and replace the failed component.

Electrical maintenance

The unit does not require routine maintenance repairs.

Do not modify the unit for any reason and do not add other devices.

The manufacturer is not liable for resulting malfunctions and problems.

Further clarification is available by contacting the manufacturer's Customer Service.

Troubleshooting table

MALFUNCTION TYPE	COMPONENT	POSSIBLE CAUSE/SOLUTION
NOISE	Fan impeller	Impeller deformed, unbalanced or loose
		Nozzle damaged
		Foreign bodies in the fan
		Motor or fan not attached well
	Bearings	Bearing worn or deteriorated
	Motor	Incorrect supply voltage
		Worn bearings
		Contact between the rotor and stator
Ducts	Excessive speed in the ducts	
	Anti-vibration joint too taut	
INSUFFICIENT AIR FLOW	Ducts	Load losses superior to the demand
		Obstructions in the ducts
	Filters	too dirty
Heat exchange coils	too dirty	
EXCESSIVE AIR FLOW	Ducts	Terminals not installed
	Unit	Filters not inserted
		Access doors open
		Dampers not calibrated
INSUFFICIENT THERMAL EFFICIENCY	Heat exchange coil	Incorrect connection of inlet/outlet piping
		Heat exchange coil dirty
		Air bubbles in the pipes
		Excessive air flow
	Electric pump	Insufficient water flow
		insufficient pressure
		Wrong direction of rotation
	Fluid	Temperature different from the project
Incorrect regulation bodies		
WATER LEAK	Heat exchange coil	Leak from the heat exchange coil due to corrosion
	Fan section	Dragging of drops due to high air velocity
		Siphon connected incorrectly
		Clogged "overflow" drain

DAIKIN APPLIED EUROPE S.p.A. Via Piani S. Maria, 72 - 00072 Ariccia (Rome) Italy - www.daikinapplied.eu

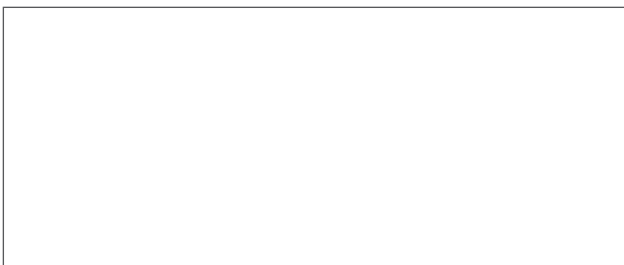

This publication is drawn up only as technical support and does not constitute a binding commitment for Daikin Applied Europe S.p.A. Daikin Applied Europe S.p.A. has drawn up the content to the best of its ability. No explicit or implicit guarantee is given as to the completeness, precision or reliability of its content. All the data and specifications contained herein are subject to change without notice. The data stated at the time of the order prevail. Daikin Applied Europe S.p.A. accepts no liability whatsoever for any direct or indirect damage, in the broadest sense of the word, deriving from or associated with the use and/or interpretation of this publication.
All content is protected by the copyright of Daikin Applied Europe S.p.A.

D-EIMAH04002-26_00EN