

DAIKIN



Public

REV	07
Date	04/2026
Supersedes	D-EIMHP01501-22_06EN

Installation, Operation and Maintenance Manual

D-EIMHP01501-22_07EN

PACKAGED WATER-COOLED HEAT PUMPS

**EWVQ014KCW1N
EWVQ025KCW1N
EWVQ033KCW1N
EWVQ049KCW1N
EWVQ064KCW1N**

Original translation

INDEX

1	INTRODUCTION	6
1.1	Description	6
1.2	Important information regarding the refrigerant used	7
1.3	Installation information	7
1.3.1	Selection of location	7
2	INSPECTING AND HANDLING THE UNIT	8
2.1	Unpacking and placing the unit	8
3	OPERATION RANGE	9
4	MECHANICAL INSTALLATION	10
4.1	Checking the water circuit	10
4.2	Connecting the water circuit	12
4.3	Water charge, flow and quality	12
4.4	Plant water content	12
4.5	Piping insulation	13
4.5.1	Antifreeze protection for BPHE and recovery exchangers	13
5	ELECTRICAL INSTALLATION	14
5.1	Field wiring	14
5.1.1	Power circuit and cable requirements	14
5.1.2	Interconnection cables	14
6	OPERATION	15
6.1	Operator's responsibilities	15
7	MAINTENANCE	16
7.1	Routine maintenance	16
8	SERVICE AND LIMITED WARRANTY	19
9	BEFORE STARTING	20

LIST OF TABLES

Table 1-	Technical specifications (1)	6
Table 2-	Electrical specifications (1)	6
Table 3-	Water quality specifications	11
Table 4-	Water flow operation range	12
Table 5-	Impedance Z	14
Table 6-	R410A Pressure / temperature table	16
Table 7-	Standard Routine Maintenance Plan	17
Table 8 –	Routine Maintenance Plan for Critical Application and/or Highly Aggressive Environment	18
Table 9-	Standards steps to go through before starting the unit	20

LIST OF FIGURES

Figure 1-	Operating limits on EWWQ014-033	9
Figure 2-	Operating limits EWWQ049-064	9
Figure 3-	Refrigerant circuit scheme EWWQ 014 - 033 KCW1N	3
Figure 4-	Refrigerant circuit scheme EWWQ 049 - 064 KCW1N	4

Figure 1- Refrigerant circuit scheme EWWQ 014 - 033 KCW1N

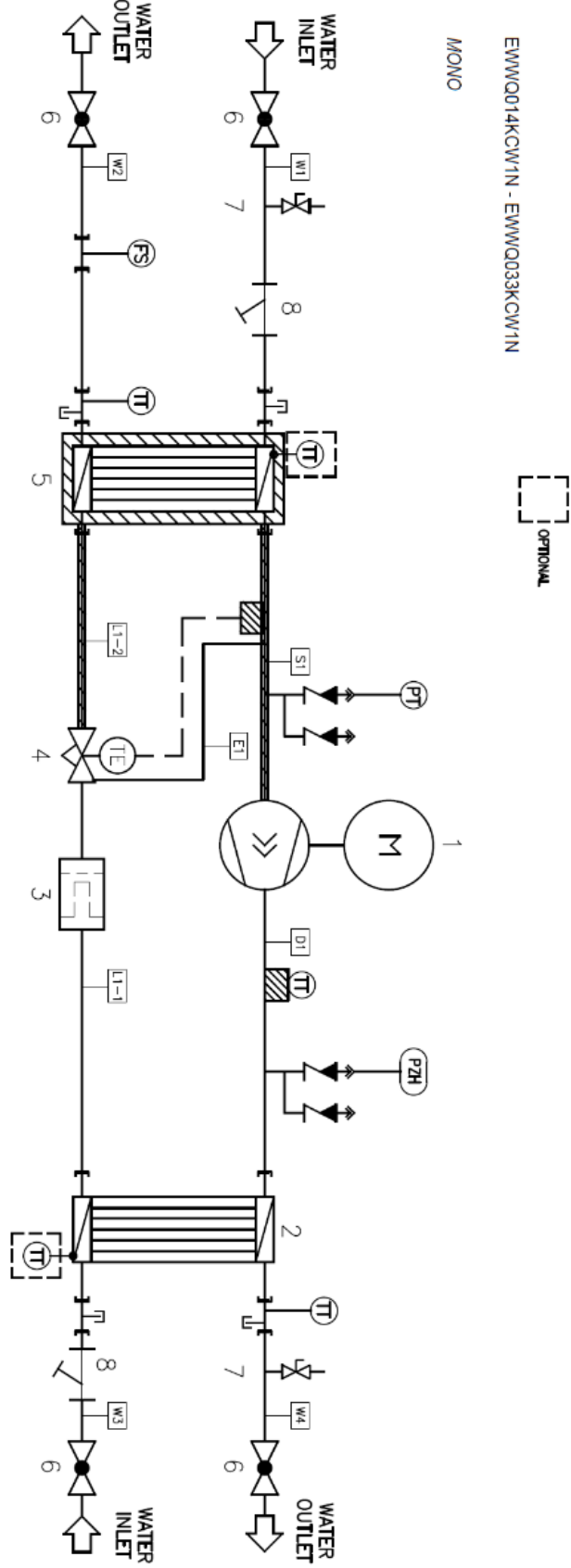
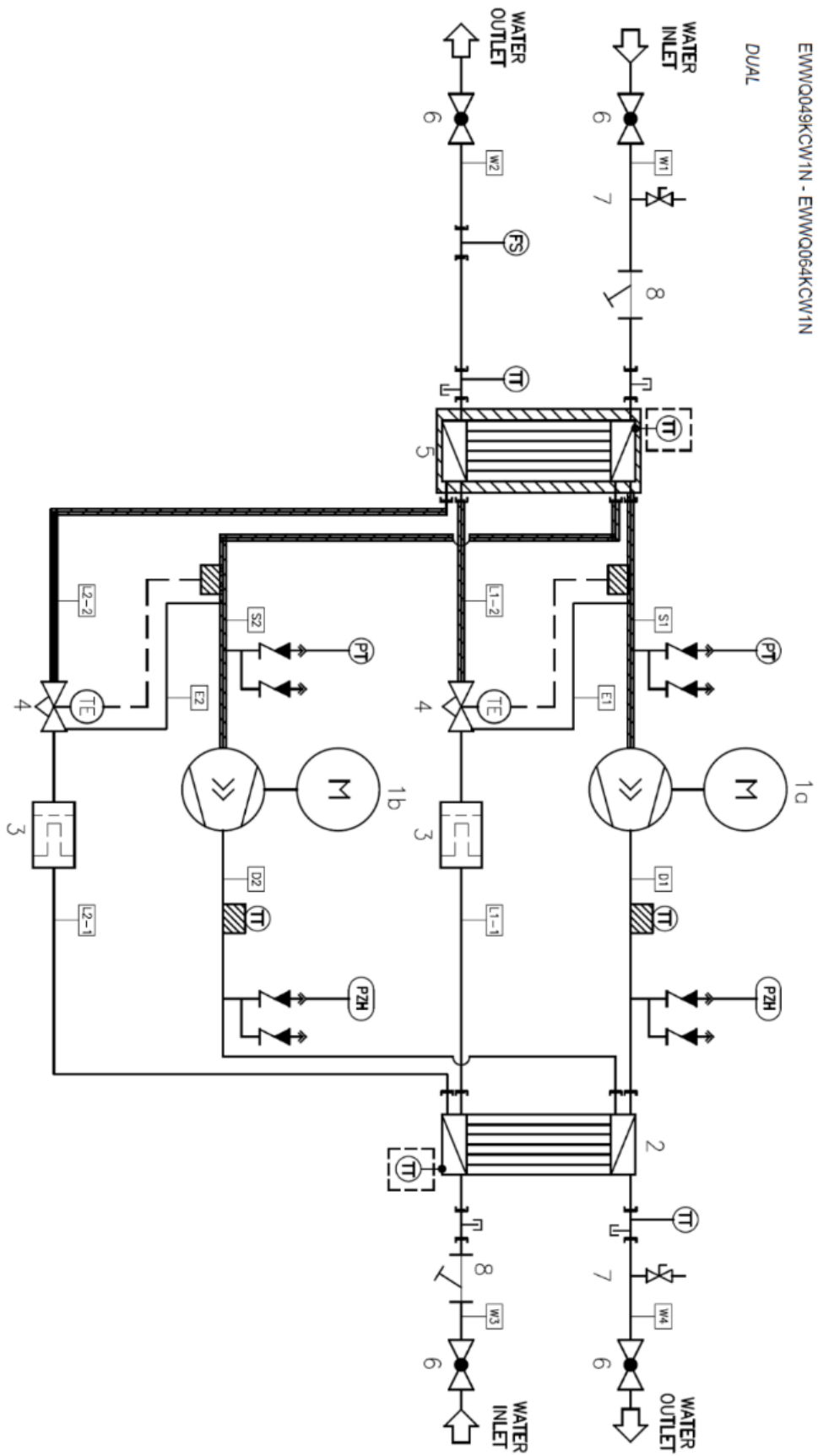

Figure 2- Refrigerant circuit scheme EWWQ 049 - 064 KCW1N



LEGEND

POS.	COMPONENT
1	COMPRESSOR
2	CONDENSER (NPHE)
3	DRIER FILTER
4	THERMOSTATIC EXPANSION VALVE
5	EVAPORATOR (BPHE)
6	BALL VALVE (OPTIONAL)
7	AIR PURGE VALVE (OPTIONAL)

POS.	COMPONENT CONNECTION
D1	COMPRESSOR-CONDENSER
L1-1/L2-1	CONDENSER-THERM.EXP. VALVE
L1-2/L2-2	THERM.EXP. VALVE-EVAPORATOR
S1	EVAPORATOR-COMPRESSOR
S2	EVAPORATOR-COMPRESSOR
W1/W3	WATER INLET ASSEMBLY (Included kit, but optional mounting)
W2/W4	WATER OUTLET ASSEMBLY (Included kit, but optional mounting)
E1/E2	EQUALIZER PIPE
INSTRUMENTS	
TT	TEMPERATURE SENSOR
PT	PRESSURE TRANSDUCER (6, 5 bar)
PZH	HIGH PRESSURE SWITCH (40, 7 bar)
FS	FLOW SWITCH

1 INTRODUCTION

This manual is an important supporting document for qualified personnel, but it is not intended to replace such personnel.



**READ THIS MANUAL CAREFULLY BEFORE INSTALLING AND STARTING UP THE UNIT.
IMPROPER INSTALLATION COULD RESULT IN ELECTRIC SHOCK, SHORT-CIRCUIT, LEAKS, FIRE
OR OTHER DAMAGE TO THE EQUIPMENT OR INJURE TO PEOPLE.**



**THE UNIT MUST BE INSTALLED BY A PROFESSIONAL OPERATOR/TECHNICIAN
UNIT STARTUP HAS TO BE PERFORMED BY AUTHORIZED AND TRAINED PROFESSIONAL
ALL ACTIVITIES HAVE TO BE PERFORMED ACCORDING TO LOCAL LAWS AND REGULATION.**



**UNIT INSTALLATION AND START UP IS ABSOLUTELY FORBIDDEN IF ALL INSTRUCTION
CONTAINED IN THIS MANUAL ARE NOT CLEAR.
IF CASE OF DOUBT CONTACT THE MANUFACTURER REPRESENTATIVE FOR ADVICE AND
INFORMATION.**

1.1 Description

The Daikin EWWQ-KC packaged water-cooled water chillers are designed for indoor installation and used for cooling and/or heating applications. The units are available in 7 standard sizes with nominal cooling capacities ranging from 14 to 64 kW.

The EWWQ units can be combined with Daikin fan coil units or air handling units for air conditioning purposes. They can also be used for supplying chilled water for process cooling.

The present installation manual describes the procedures for unpacking, installing, and connecting the EWWQ units.

This appliance is intended to be used by expert or trained users in shops, in light industry and on farms, or for commercial use by lay persons.

Sound pressure level is less than 70 dB(A).

Table 1- Technical specifications (1)

General EWWQ		014	025	033
Dimensions HxWxD	(mm)	600x600x600		
Machine Weight	(kg)	120	170	175
Connections				
Water inlet		G1		
Water outlet		G1		
General EWWQ		049	064	
Dimensions HxWxD	(mm)	600x600x1200		
Machine Weight	(kg)	310	340	
Connections				
Water inlet		G 1-1/2		
Water outlet		G 1-1/2		

Table 2- Electrical specifications (1)

General EWWQ		014-064
Power supply		
Phase		3N~
Frequency	(Hz)	50
Voltage	(V)	400
Voltage tolerance	(%)	±10

1.2 Important information regarding the refrigerant used

This product contains fluorinated greenhouse gases covered by the Kyoto Protocol. Do not vent gases into the atmosphere.

Refrigerant type: R410A

GWP ⁽¹⁾ value: 2090

The refrigerant quantity is indicated on the unit's name plate.

⁽¹⁾ GWP = global warming potential

1.3 Installation information

1.3.1 Selection of location

The units are designed for indoor installation and should be installed in a location that meets the following requirements:

1. The foundation is strong enough to support the weight of the unit and the floor is flat to prevent vibration and noise generation.
2. The space around the unit is adequate for servicing.
3. There is no danger of fire due to leakage of non-flammable gas.
4. Select the location of the unit in such a way that the sound generated by the unit does not disturb anyone.
5. Ensure that water cannot cause any damage to the location in case it drips out of the unit.

The equipment is not intended for use in a potentially explosive atmosphere.

2 INSPECTING AND HANDLING THE UNIT

At delivery, the unit should be checked, and any damage should be reported immediately to the carrier claims agent.

2.1 Unpacking and placing the unit

1. Cut the straps and remove the cardboard box from the unit.
2. Cut the straps and remove the cardboard box with water piping from the pallet.
3. Remove the four screws fixing the unit to the pallet.
4. Level the unit in both directions.
5. Use four anchor bolts with M8 thread to fix the unit in concrete (directly or using the floor standing supports).
6. Remove the service front plate.

3 OPERATION RANGE

Figure 3- Operating limits on EWWQ014-033

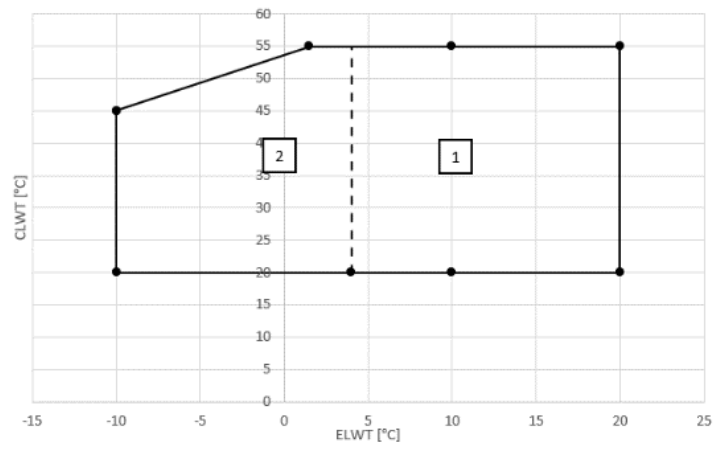
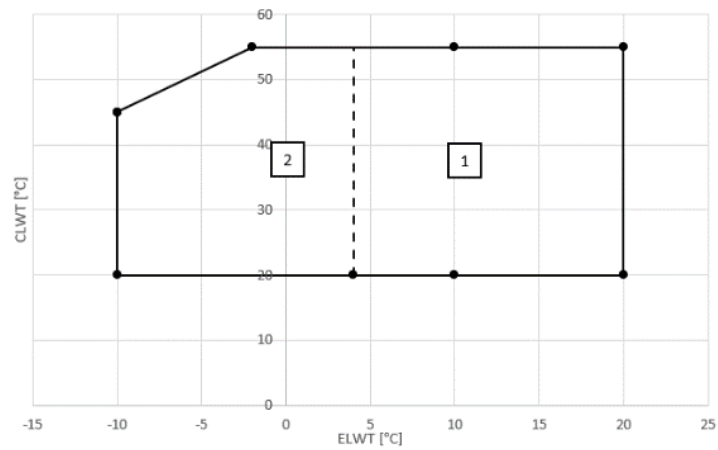

Figure 4- Operating limits EWWQ049-064



- ELWT: Evaporator leaving water temperature
- CLWT: Condenser leaving water temperature
- 1: Operation with water
- 2: Operation with glycol (below ELWT=4°C)

4 MECHANICAL INSTALLATION

4.1 Checking the water circuit

The units are equipped with water inlets and water outlets for connection to a chilled water circuit and to a hot water circuit. These circuits must be provided by a licensed technician and must comply with all relevant European and national regulations.







The unit is only to be used in a closed water system. Application in an open water circuit can lead to excessive corrosion of the water piping.



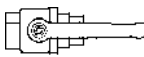

Before continuing the installation of the unit, check the following points:

- **Additional components not delivered with the unit**
 1. A circulation pump must be provided in such a way that it discharges the water directly into the heat exchanger.
 2. Drain taps must be provided at all low points of the system to permit complete drainage of the circuit during maintenance or in case of shut down.
 3. Anti-vibration systems in all water piping connected to the chiller are recommended to avoid straining the piping and transmitting vibration and noise.

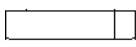
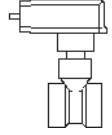
- **Additional water piping delivered with the unit**

All additional water piping must be installed on the system according to the piping diagram as mentioned in the operation manual. The flowswitch must be connected as described on the wiring diagram. See also chapter "Before starting".

Plastic bag 1	Water piping evaporator
	2x Ball valve
	1x Water filter
	1x Air purge
	1x T-joint for air purge
	2x Flowswitch pipe
	1x Flowswitch + 1x T-joint

Plastic bag 2	Water piping condenser
	2x Ball valve
	1x Water filter
	1x Air purge
	1x T-joint for air purge

1. The flowswitch must be installed in the water outlet pipe of the evaporator to prevent the unit from operating at a water flow which is too low.



It is very important to install the flowswitch as shown in the figure. Observe the position of the flowswitch in relation to the direction of the water flow. If the flowswitch is mounted in another position, the unit is not properly protected against freezing.

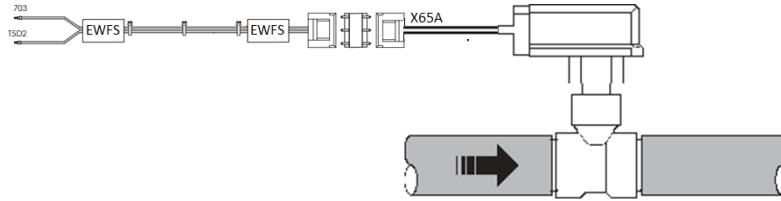

A specific terminal is provided in the switch box for the electrical connection of the flowswitch. Refer to the wiring diagram

2. Shut-off valves must be installed at the unit so that normal servicing of the water filter can be accomplished without draining the complete system.
3. Air purge valves must be provided at all high points of the system. The vents should be located at points which are easily accessible for servicing.
4. The water filter must be installed in front of the unit for removing dirt from the water to prevent damage to the unit or malfunctioning of the evaporator or condenser. The water filter must be cleaned on a regular base.

Table 3-Water quality specifications

DAE Water quality requirements	BPHE
pH (25°C)	7.5-9.0
Electrical conductivity (25°C)	<500 µS/cm
Chloride ion	
Chlorine molecular	<1.0mg Cl ₂ /l
Sulphate ion (SO ₄ ⁻⁻ /l)	<100 mg SO ₄ ⁻⁻ /l
Alkalinity	<100 mg CaCO ₃ /l
Total Hardness	80-150 mg CaCO ₃ /l
Iron	
Copper	-
Ammonium ion (NH ₃)	<0.5mg NH ₄ ⁺ /l
Silica	
Dissolved Oxygen	
Total dissolved solids	
Hydrogen carbonate (HCO ⁻⁻⁻)	60-200 mg HCO ₃ /l
(HCO ⁻⁻⁻)/(SO ₄ ⁻⁻)	>0.5
(Ca+Mg)/(HCO ⁻⁻⁻)	>1.6

4.2 Connecting the water circuit

The evaporator and condenser are foreseen of GAS male pipe thread for the water inlet and outlet (refer to the outlook diagram). Evaporator and condenser water connections are to be made in accordance with the outlook diagram, respecting the water in- and outlet.

If air, moisture, or dust gets in the water circuit, problems may occur. Therefore, always consider the following when connecting the water circuit:

1. Use clean pipes only.
2. Hold the pipe end downwards when removing burrs.
3. Cover the pipe end when inserting it through wall so that no dust and dirt enter.



Use a good thread sealant for the sealing of the connections. The sealing must be able to withstand the pressures and temperatures of the system, it must also be resistant to the used glycol in the water.
The external surface of the water pipes must be adequately protected against corrosion.

4.3 Water charge, flow and quality

To assure proper operation of the unit a minimum water volume is required in the system and the water flow through the evaporator must be within the operation range as specified in the table below.

Table 4- Water flow operation range

	Minimum water volume (l)	Minimum water flow	Maximum water flow
EWQ014	62	31 l/min	75 l/min
EWQ025	134	53 l/min	123 l/min
EWQ033	155	76 l/min	186 l/min
EWQ049	205	101 l/min	247 l/min
EWQ064	311	152 l/min	373 l/min



The water pressure should not exceed the maximum working pressure of 10 bar.



Provide adequate safeguards in the water circuit to make sure that the water pressure will never exceed the maximum allowable working pressure.

4.4 Plant water content

The water content of the systems should have a minimum water amount to avoid excessive stress (start and stops) on the compressors.

Design considerations for water volume are the minimum cooling load, the water temperature setpoint differential and the cycle time for the compressors.

As a general indication, the system water content should not be less than the values deriving from the following formula:

$$\text{Single circuit Unit} \rightarrow 5 \frac{\text{lt}}{\text{kW nominal}}$$

$$\text{Dual circuit Unit} \rightarrow 3,5 \frac{\text{lt}}{\text{kW nominal}}$$

kW_{nominal} = Cooling capacity at 12/7°C OAT=35°C

The above rule of thumb derives from the following formula, as the relative volume of water capable of maintaining the water temperature setpoint differential during the minimum load transient avoiding an excessive starts and stops of the compressor itself (which depends on the compressor technology):

$$\text{Water Volume} = \frac{CC [W] \times \text{Min load } \% \times DNCS [s]}{FD \left[\frac{g}{L} \right] * SH \left[\frac{J}{g^{\circ}C} \right] * (DT) [^{\circ}C]}$$

CC = Cooling Capacity

DNCS = Delay to next Compressor Start

FD = Fluid Density
SH = Specific Heat
DT = Water Temperature Setpoint Differential

A properly designed storage tank should be added if the system components do not provide sufficient water volume.

By default, the unit is set to have a water temperature setpoint differential in line with Comfort application which allows to operate with the minimum volume mentioned in the previous formula.

However, if a smaller temperature differential is set, as in the case of Process applications where temperature fluctuations must be avoided, a larger minimum water volume will be required.

To ensure proper operation of the unit when changing the value of setting, the minimum water volume must be corrected.

In case of more than one installed unit, the overall capacity of the installation must be considered in the calculation so summing the water content of each unit.

4.5 Piping insulation

The complete water circuit, inclusive all piping, must be insulated to prevent condensation and reduction of the cooling capacity.

4.5.1 Antifreeze protection for BPHE and recovery exchangers

If the heat exchangers are completely empty and cleaned with antifreeze solution, additional methods can be used against freezing.

The following protection methods must be considered when designing the system as a whole:

1. continuous water flow circulation inside piping and exchangers.
2. addition of an appropriate amount of glycol inside the water circuit or, as alternative, an additional heat insulation and heating of exposed piping (internal and external to the unit);
3. if the unit does not work during the winter season, emptying and cleaning of the heat exchanger.

It is the responsibility of the installer and/or of local maintenance personnel to ensure that described antifreeze methods are used.

Make sure that appropriate antifreeze protection is always maintained. Failing to follow the instructions above could result in unit damage.



Damage caused by freezing is excluded from the warranty, therefore Daikin Applied Europe S.p.A. declines all responsibility.

5 ELECTRICAL INSTALLATION

5.1 Field wiring



All field wiring and components must be installed by a licensed electrician and must comply with relevant European and national regulations.

The field wiring must be carried out in accordance with the wiring diagram supplied with the unit and the instructions given below.

Be sure to use a dedicated power circuit. Never use a power supply shared by another appliance.



During the removal of the control cabinet door, disconnect the display cable before removing the panel completely. the display cable can be disconnected without the need to unlock any latch.

5.1.1 Power circuit and cable requirements

1. The electrical power supply to the unit must be arranged so that it can be switched on or off independently of the electrical supply to other items of the plant and equipment in general.
2. A power circuit must be provided for connection of the unit. This circuit must be protected with the required safety devices, i.e., a circuit breaker, a slow blow fuse on each phase and an earth leak detector. Recommended fuses are mentioned on the wiring diagram supplied with the unit.



Switch off the main isolator switch before making any connections (switch off the circuit breaker, remove or switch off the fuses).

5.1.1.1 Connection of the water-cooled water chiller power supply

1. Install cable gland to proper tight main power supply cable
2. Using the appropriate cable, connect the power circuit to the N, L1, L2 and L3 terminals of the unit (cable section 2.5~ 16mm²).
3. Connect the earth conductor (yellow/green) to the earthing terminal PE.

5.1.1.2 Point for attention regarding quality of the public electric power supply

- This equipment complies with EN/IEC 61000-3-11 provided that the system impedance Z_{sys} is less than or equal to Z_{max} at the interface point between the user's supply and the public system. It is the responsibility of the installer or user of the equipment to ensure, by consultation with the distribution network operator, if necessary, that the equipment is connected only to a supply with a system impedance Z_{sys} less than or equal to Z_{max} .

Table 5- Impedance Z

	Z_{max} (Ω)
EWWQ014	0.28
EWWQ025	0.23
EWWQ033	0.21
EWWQ049	0.22
EWWQ064	0.20

- Only for EWWQ014~064: Equipment complying with EN/IEC 61000-3-12

5.1.2 Interconnection cables

- Voltage free contact

The PCB is provided with some voltage free contacts to indicate the status of the unit. These voltage free contacts can be wired as described on the wiring diagram.

- Remote inputs

Besides the voltage free contacts, there are also possibilities to install remote inputs. They can be installed as shown on the wiring diagram.

6 OPERATION

6.1 Operator's responsibilities

It is essential that the operator is appropriately trained and becomes familiar with the system before operating the unit. In addition to reading this manual, the operator must study the microprocessor operating manual and the wiring diagram to understand start-up sequence, operation, shutdown sequence and operation of all the safety devices.

During the unit initial start-up phase, a technician authorized by the manufacturer is available to answer any questions and to give instructions as to the correct operating procedures.

The operator must keep a record of operating data for every R41 installed unit. Another registration must also be kept for all the periodic maintenance and assistance activities.

If the operator notes abnormal or unusual operating conditions, he is advised to consult the technical service authorized by the manufacturer.



***If the unit is switched off, the compressor oil heater cannot be used. Once the unit is reconnected to the mains, leave the compressor oil heater charged for at least 6 hours before restarting the unit.
Failure to observe this rule may cause damage to the compressors due to excessive accumulation of liquid inside them.***

This unit represents a substantial investment and deserves the attention and care to keep this equipment in good working order.

However, during operation and maintenance it is essential to observe the following instructions:

- Do not allow unauthorized and / or unqualified personnel to access the unit.
- It is forbidden to access the electrical components without having opened the unit main switch and switched off the power supply.
- It is forbidden to access the electrical components without using an insulating platform. Do not access the electrical components if water and/or moisture are present.
- Verify that all operations on the refrigerant circuit and on the components under pressure are carried out exclusively by qualified personnel.
- The replacement of the compressors must be carried out exclusively by qualified personnel.
- Sharp edges and the surface of the condenser section could cause injury. Avoid direct contact and use adequate protection device.
- Do not introduce solid objects into the water pipes while the unit is connected to the system.
- It is absolutely forbidden to remove all protections of moving parts.

In case of sudden stop of the unit, follow the instructions on the Control Panel Operating Manual which is part of the on-board documentation delivered to the end user.

It is strongly recommended to perform installation and maintenance with other people.



Avoid installing the unit in areas that could be dangerous during maintenance operations, such as platforms without parapets or railings or areas not complying with the clearance requirements around the unit.

Table 6-R410A Pressure / temperature table

°C	Bar	°C	Bar	°C	Bar
-13	5.22	14	12.30	41	24.95
-12	5.41	15	12.65	42	25.56
-11	5.60	16	13.02	43	26.18
-10	5.79	17	13.39	44	26.81
-9	6.00	18	13.77	45	27.45
-8	6.20	19	14.15	46	28.10
-7	6.42	20	14.55	47	28.77
-6	6.63	21	14.95	48	29.44
-5	6.86	22	15.37	49	30.13
-4	7.09	23	15.79	50	30.84
-3	7.32	24	16.22	51	31.55
-2	7.56	25	16.65	52	32.28
-1	7.81	26	17.10	53	33.02
0	8.06	27	17.56	54	33.78
1	8.32	28	18.02	55	34.55
2	8.59	29	18.49	56	35.33
3	8.86	30	18.98	57	36.13
4	9.14	31	19.47	58	36.95
5	9.42	32	19.97	59	37.78
6	9.71	33	20.48	60	38.62
7	10.01	34	21.01	61	39.48
8	10.32	35	21.54	62	40.36
9	10.63	36	22.08	63	41.25
10	10.95	37	22.63	64	42.16
11	11.27	38	23.20	65	43.09
12	11.61	39	23.77	66	44.04
13	11.95	40	24.36	67	45.01

7.1 Routine maintenance

This unit must be maintained by qualified technicians. Before beginning any work on the system, the personnel shall assure that all security precautions have been taken.

Neglecting unit maintenance could degrade all parts of the units (compressors, frames, pipes, etc.) with negative effect on performances and functionality.

There are two different levels of maintenance, which can be chosen according to the type of application (critical/noncritical) or to the installation environment (highly aggressive).

Examples of critical applications are process cooling, data centres, etc.

Highly Aggressive Environments can be defined as follows:

- Industrial environment (with possible concentration of fumes result of combustion and chemical process).
- Coastal environment.
- Highly polluted urban environment.
- Rural environment close to of animal excrement and fertilizers, and high concentration of exhaust gas from diesel generators.
- Desert areas with risk of sandstorms.
- Combinations of the above.
- Unit exposed to a highly aggressive environment can face corrosion in a shorter time than ones installed on a standard environment. Corrosion causes a rapid rusting of the frame core, consequently, decreases unit structure lifetime. To avoid that, it is necessary to wash periodically the frame surfaces with water and suitable detergents.
- In case of part of unit frame paint came off, it is important to stop its progressive deterioration by repainting the exposed parts using proper products. Please contact the factory to get the required products specifications.
- In case of just salt deposits are present, it is enough to rinse the parts with fresh water.



All electrical maintenance activities must be performed by qualified personnel. Make sure the system is switched off and the main switch of the unit open. Failure to observe this rule could result in serious personal injury. When the unit is turned off, but the disconnection switch is in the closed position, the unused circuits will still be active.

The maintenance of the electrical system consists of the application of some general rules as follows:

1. the current absorbed by the compressor must be compared to the rated value. Normally the value of the absorbed current

is lower than the rated value that corresponds to the absorption of the full load compressor at the maximum operating conditions.

2. at least once every three months all the security checks must be made to verify their functionality. Each appliance, with aging, can change its point of operation and this must be monitored to adjust it or replace it. The pump interlocks and flow switches must be checked to make sure that they interrupt the control circuit if they intervene.

Table 7 lists all Maintenance activities for standard applications and standard environment.

Table 8 lists all Maintenance activities for critical applications or highly aggressive environment.

Table 7-Standard Routine Maintenance Plan

List of Activities	Weekly	Monthly (Note 1)	Semiannual	Yearly/Seasonal (Note 2)
General:				
Reading of operating data (Note 3)	X			
Visual inspection of unit for any damage and/or loosening		X		
Verification of thermal insulation integrity		X		
Cleaning		X		
Paint where necessary				X
Analysis of water (Note 4)				X
Check of flow switch operation		X		
Electrical Installation:				
Verification of start-up sequence				X
Verify contactor wear – Replace if necessary				X
Verify that all electrical terminals are tight – Tighten if necessary		X (Quarterly)		
Clean inside the electrical panel				X
Visual inspection of components for any signs of overheating		X		
Verify operation of compressor and electrical resistance		X		
Refrigeration circuit:				
Check for any refrigerant leakage (leak test)		X		
Analyse compressor vibrations				X
Check and application of additional protective paint layer(Note 7)			X	
Hydraulic circuit:				
Check for any water leakage		X		
Check hydraulic connections		X		
Check the pressure at the exchangers water inlet		X		
Clean the water filter				X
Check the glycol concentration				X
Check the water flow rate		X		
BPHE:				
Check the cleaning of the BPHE				X

Notes:

1. Monthly activities include all the weekly ones.
2. The annual (or early season) activities include all weekly and monthly activities.
3. Daily reading of the operating values of the unit allows maintaining high observational standards.
4. Check for any dissolved metals.
5. Clean condenser banks with clean water and water heat exchangers with appropriate chemicals. Particles and fibres could clog up the exchangers, especially for water exchangers pay attention if water rich in calcium carbonate is used. An increase in pressure drops or a decrease in thermal efficiency means that the heat exchangers are clogged. In environments with a high concentration of airborne particles, it might be necessary to clean the condenser bank more often.
6. Units placed or stored in a Highly Aggressive Environment for long time without operation are still subject to those routine maintenance steps.
7. The protective paint layer must be applied on:all brazing and joints of copper refrigerant pipes; drier filter plate; Rotalock valves and flanges of refrigerant circuit; all BPHE not insulated; anti-chattering capillars.

Table 8 – Routine Maintenance Plan for Critical Application and/or Highly Aggressive Environment

List of activities (Note 8)	Weekly	Monthly (Note 1)	Semiannual	Yearly/Seasonal (Note 2)
General:				
Reading of operating data (Note 3)	X			
Visual inspection of unit for any damage and/or loosening		X		
Verification of thermal insulation integrity		X		
Cleaning		X		
Paint where necessary				X
Analysis of water (Note 4)				X
Check of flow switch operation		X		
Electrical Installation:				
Verification of start-up sequence				X
Verify contactor wear – Replace if necessary				X
Verify that all electrical terminals are tight – Tighten if necessary				X
Clean inside the electrical panel		X		
Visual inspection of components for any signs of overheating		X		
Verify operation of compressor and electrical resistance		X		
Measure with the Megger the compressor motor insulation				X
Refrigeration circuit:				
Check for any refrigerant leakage (leak test)		X		
Analyse compressor vibrations				X
Check and application of an additional layer of protective paint (Note 7)			X	
Hydraulic circuit:				
Check for any water leakage		X		
Check hydraulic connections		X		
Check the pressure at the exchangers water inlet		X		
Clean the water filter				X
Check the glycol concentration				X
Check the water flow rate		X		
BPHE:				
Check the cleaning of the BPHE				X

Notes:

1. Monthly activities include all the weekly ones.
2. The annual (or early season) activities include all weekly and monthly activities.
3. Daily reading of the operating values of the unit allows maintaining high observational standards.
4. Check for any dissolved metals.
5. Clean condenser banks with clean water and water heat exchangers with appropriate chemicals. Particles and fibres could clog up the exchangers, especially for water exchangers pay attention if water rich in calcium carbonate is used. An increase in pressure drops or a decrease in thermal efficiency means that the heat exchangers are clogged. In environments with a high concentration of airborne particles, it might be necessary to clean the condenser bank more often.
6. Units placed or stored in a Highly Aggressive Environment for long time without operation are still subject to those routine maintenance steps.
7. The protective paint layer must be applied on: all brazing and joints of copper refrigerant pipes; drier filter plate; Rotalock valves and flanges of refrigerant circuit; All BPHE not insulated; anti-chattering capillaries.

8 SERVICE AND LIMITED WARRANTY

All units are factory tested and guaranteed for 12 months as of the first start-up or 18 months as of delivery.

These units have been developed and constructed according to high quality standards ensuring years of failure free operation.

However, the unit requires maintenance even during the warranty period, from the time of installation and not just from the commissioning date. We strongly advise stipulating a maintenance contract with a service authorized by the manufacturer to ensure efficient and problem free service, thanks to the expertise and experience of our personnel.

It must be borne in mind that operating the unit in an inappropriate manner, beyond its operating limits or not performing proper maintenance according to this manual can void the warranty. Observe the following points, to conform to warranty limits:

1. The unit cannot function beyond the specified limits.
2. The electrical power supply must be within the voltage limits and without voltage harmonics or sudden changes.
3. The three-phase power supply must not have an unbalance between phases exceeding 3%. The unit must stay turned off until the electrical problem has been solved.
4. No safety device, either mechanical, electrical, or electronic must be disabled or overridden.
5. The water used for filling the water circuit must be clean and suitably treated. A mechanical filter must be installed at the point closest to the BPHE inlet.
6. The value of the BPHE water flow must be included in the declared range for the unit considered, refer to the CSS selection software.

9 BEFORE STARTING



The unit should not be started, not even for a very short period, before the following pre-commissioning checklist is filled out completely.

Table 9- Standards steps to go through before starting the unit

Tick when checked	
1	Check for external damage
2	Install main fuses, earth leak detector and main switch. Recommended fuses: aM according to IEC standard 269-2. Refer to the wiring diagram for size.
3	Supply the main voltage and check if it is within the allowable $\pm 10\%$ limits of the nameplate rating. The electrical main power supply must be arranged so, that it can be switched on or off independently of the electrical supply to other items of the plant and equipment in general. Refer to the wiring diagram, terminals N, L1, L2, L3 and PE.
4	Supply water to the evaporator and condenser and verify if waterflow is within the limits as given in the table under "Water charge, flow and quality".
5	The piping must be completely purged. See also chapter "Checking the water circuit".
6	Connect flowswitch and pump contacts, so that the unit can only come in operation when the water pumps are running and the waterflow is sufficient. Make sure a water filter is installed.
7	Connect the field wiring pumps start-stop.
8	Connect the fiels wiring for remote control.

I do confirm having executed and checked all the above-mentioned items.

Date

Signature

Keep for future reference

NOTES

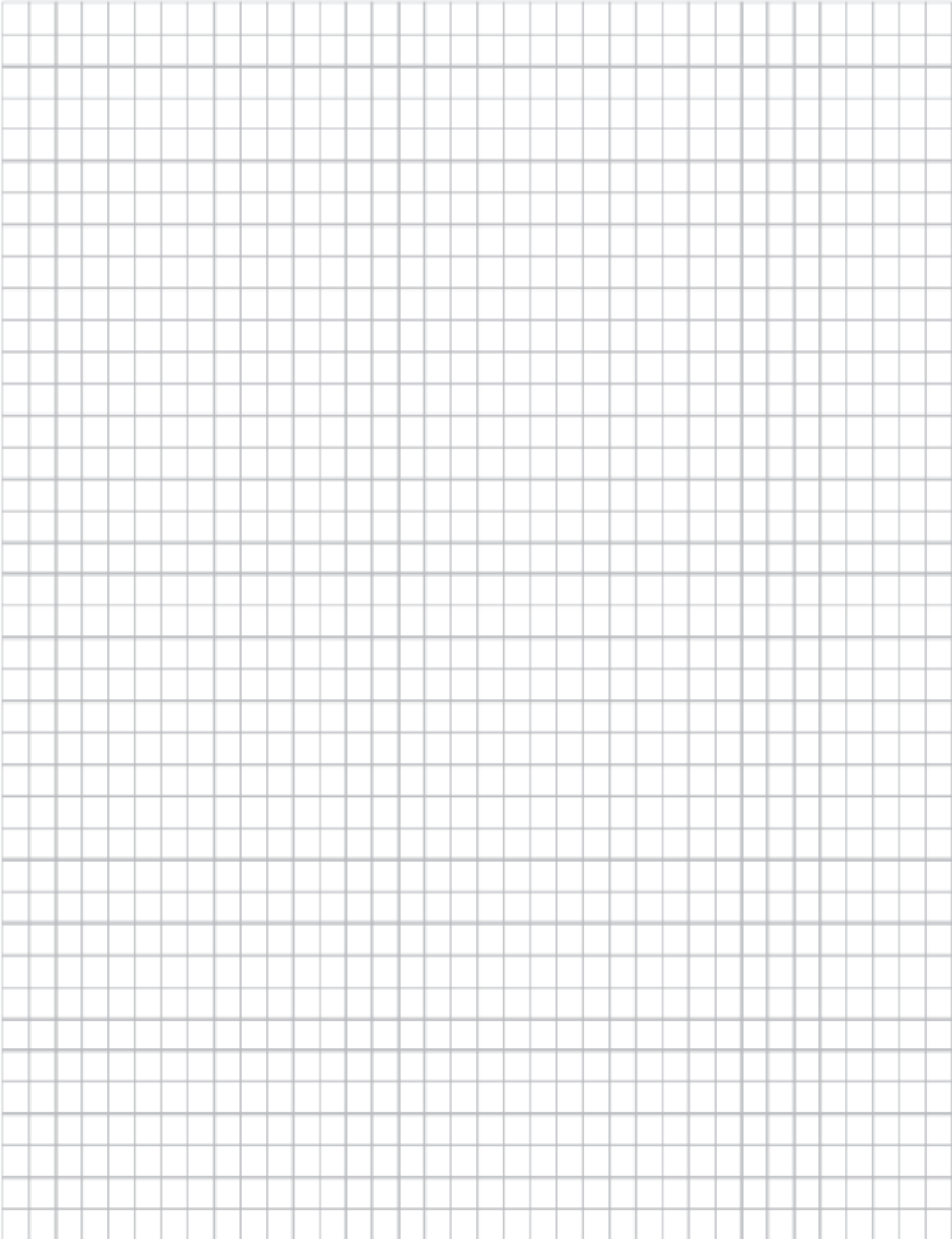

The present publication is drawn up by of information only and does not constitute an offer binding upon Daikin Applied Europe S.p.A.. Daikin Applied Europe S.p.A. has compiled the content of this publication to the best of its knowledge. No express or implied warranty is given for the completeness, accuracy, reliability or fitness for particular purpose of its content, and the products and services presented therein. Specifications are subject to change without prior notice. Refer to the data communicated at the time of the order. Daikin Applied Europe S.p.A. explicitly rejects any liability for any direct or indirect damage, in the broadest sense, arising from or related to the use and/or interpretation of this publication. All content is copyrighted by Daikin Applied Europe S.p.A..

DAIKIN APPLIED EUROPE S.p.A.

Via Piani di Santa Maria, 72 - 00072 Ariccia (Roma) - Italia

Tel: (+39) 06 93 73 11 - Fax: (+39) 06 93 74 014

<http://www.daikinapplied.eu>