

DAIKIN



Public

REV	00
Date	04-2026
Supersedes	-

Operating Manual
D-EOMAH04002-26_00_EN

COMPACT R AIR HANDLING UNIT

ARB

Contents

1.	About this document	4
1.1.	Revision history	4
1.2.	Notice	4
2.	Safety Information	5
3.	Introduction	6
3.1.	Basic Control System Diagnostic	6
3.2.	Room Unit Interface	6
3.2.1	Produal room	6
3.2.2	LCD	6
3.3.	Password	8
4.	Control Functions	9
5.	Configuration pages	10
5.1.	Unit Configuration	10
5.2.	Configuration Components	10
5.3.	Configuration Functions	10
5.4.	Configuration Status	10
5.5.	Restart	10
6.	Configuration	11
6.1.	Heat/Cool HMI	11
6.2.	Comfort/Eco/Boost HMI	11
6.3.	Comfort/Economy switch	11
6.4.	Precedence	12
6.4.1	Heat/Cool	12
6.4.2	Comfort/Economy	12
6.5.	Regulation	13
6.5.1	Main probe	13
6.5.2	Dynamic supply setpoint	13
6.6.	Room Unit	14
6.6.1	Regulation probe	14
6.7.	Fans	16
6.7.1	Control loop regulation	16
6.7.2	COP Function	17
6.8.	Dampers and filters	18
6.8.1	Outdoor and Exhaust air dampers	18
6.8.2	Supply and Return air filters	18
6.9.	Coils	19
6.9.1	External Pre-heating coil	19
6.9.2	ERQ Main coil	20
6.9.3	Water Main coil	21
6.9.4	Post Heating I Coil	21
6.10.	Filters	23
6.10.1	Outdoor air Pre-filter	23
6.10.2	Return air Filter	23
6.11.	Status	24

6.11.1	Polarities.....	24
6.11.2	Self-Release.....	24
6.11.3	Alarm action choice.....	24
6.11.4	DO Logic.....	25
6.11.4.1.	Global Alarm.....	25
6.11.4.2.	Unit Run.....	25
6.12.	Serial Number.....	26
6.13.	Optional POL955 A/B (OPTIONS).....	27
6.13.1	Optional POL955 A.....	27
6.13.1.1.	R32.....	27
6.13.1.2.	Return air humidity.....	28
6.13.1.3.	CO2 probe.....	28
6.13.2	Optional POL955 B.....	29
6.13.2.1.	Outdoor air humidity.....	29
6.13.2.2.	Supply air humidity.....	29
6.13.2.3.	IEQ Sensor.....	30
6.14.	Other Function.....	31
6.14.1	AHU General Alarm.....	31
6.14.2	AHU Run.....	31
6.14.3	Cool/Heat Status (Output).....	31
6.14.4	Fire Alarm.....	31
6.14.5	Comfort/Economy.....	31
6.14.6	Fan deviation alarm.....	31
6.14.7	Temperature deviation alarm.....	31
6.14.8	Unit Enable Switch.....	32
6.14.9	Supply Temperature optional.....	32
6.14.10	Humidity regulation probe.....	32
6.14.11	Cool/Heat Status (Input).....	32
6.14.12	Winter pre-heating.....	33
7.	Main Menu screen.....	34
7.1.	LCD/Web interface.....	34
8.	Actual status.....	35
9.	Mode.....	36
10.	Regulation values.....	37
11.	HMI Switch.....	38
12.	Input/Output.....	38
13.	Setpoint.....	40
13.1.	Fans.....	40
13.2.	Others.....	41
13.2.1	Filters alarm threshold.....	41
14.	Settings.....	42
14.1.	Communication.....	42
14.1.1	Licenses.....	43
14.2.	Maintenance.....	45
14.2.1	Fans.....	45

14.2.2	Rotary.....	47
14.2.3	Fan reference alarm codes.....	48
14.2.4	Rotary reference alarm codes	48
15.	Service.....	49
16.	About Unit	51
17.	Alarm	52
17.1.	Alarm list	52
17.2.	Alarm Reset	53
Appendix A.....		55

1. About this document

1.1. Revision history

Name	Revision	Date	Scope	Software version
	0	April 2026	Comfort_2.00.A_00_Package	FujinComfort_2.00.A_00

1.2. Notice

© 2014 Daikin Applied Europe, Cecchina, Roma. All rights reserved throughout the world
The following are trademarks or registered trademarks of their respective companies:

MicroTech 4	from Daikin Applied Europe	
Before starting	This document refers to the following components: POL688, POL 955, POL 822, POL895, POL871, AUC00RT room unit	
Application range	Microtech 4	Controller
Users	Users of this document are intended to be:	
	- AHU users	
	- Sales staff	
Conventions	MicroTech 4 further in this document and when proper will be referred to as "MicroTech"	

2. Safety Information

Observe all safety directions and comply with the corresponding general safety regulations in order to prevent personal injury and damage to property.

- Safety devices may not be removed, bypassed or taken out of operation.
- Apparatus and system components may only be used in a technically fault-free state. Faults that can affect safety must be rectified immediately.
- Observe the required safety instructions against excessively high contact voltages.
- The plant may not be in operation if the standard safety devices are out of operation or if their effects are influenced in some other way.
- All handling that affects the prescribed disconnection of the protective extra-low voltage (AC 24 V) must be avoided.
- **Disconnect the supply voltage before opening the apparatus cabinet. Never work when the power is on!**
- Avoid electromagnetic and other interference voltages in signal and connection cables.
- Assembly and installation of system and plant components may only be performed in accordance with corresponding installation instructions and instructions for use.
- Every electric part of the system must be protected against static charging: electronic components, open printed circuit boards, freely accessible connectors and apparatus components that are connected with the internal connection.
- All equipment that is connected to the system must be CE marked and comply with the Machine Safety Directive.

3. Introduction

This operating manual provides basic information that allows the control of the Daikin Air Handling Unit (AHU).

Compact R AHUs are used for air conditioning and air handling in terms of pressure and temperature level control.

3.1. Basic Control System Diagnostic

Unit controllers, extension modules and communication modules are equipped with two status LED, BSP and BUS, to indicate the operational status of the devices. The "BUS" LED indicates the status of the communication with the controller. The meaning of the two status LED is indicated below.

- **MAIN CONTROLLER**
- BSP LED

LED Color	Mode
Solid Green	Application running
Solid Yellow	Application loaded but not running (*) or BSP Upgrade mode active
Solid Red	Hardware Error (*)
Flashing Green	BSP startup phase. The controller needs time for starting.
Flashing Yellow	Application not loaded (*)
Flashing Yellow/Red	Fail safe mode (in case that the BSP upgrade was interrupted)
Flashing Red	BSP Error (software error*)
Flashing Red/Green	Application/BSP update or initialization

(*) Contact Service.

3.2. Room Unit Interface

3.2.1 AUC00RT

The AUC00RT transmitters are very versatile room transmitters that can be equipped with several measurements. All transmitters are equipped with temperature measurement and 2.8" multicolor touchscreen display. You can use the touchscreen for viewing measurement information, adjusting setpoints and using VAV forcing function, [see Appendix A for more information](#). The following options are also available:

- Humidity measurement (-RH models)
- CO2 concentration measurement (-CO2 models)
- Relay output (-R models)
- Modbus RTU communication (-MOD models)

All dimensions are in millimeters (mm).

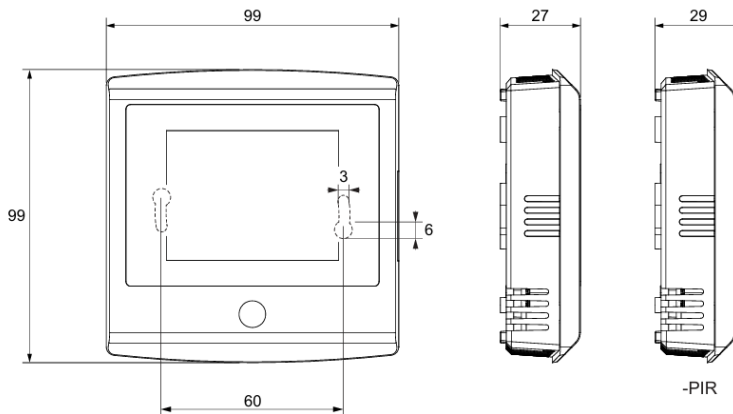

Web ion

3.2.2 LCD

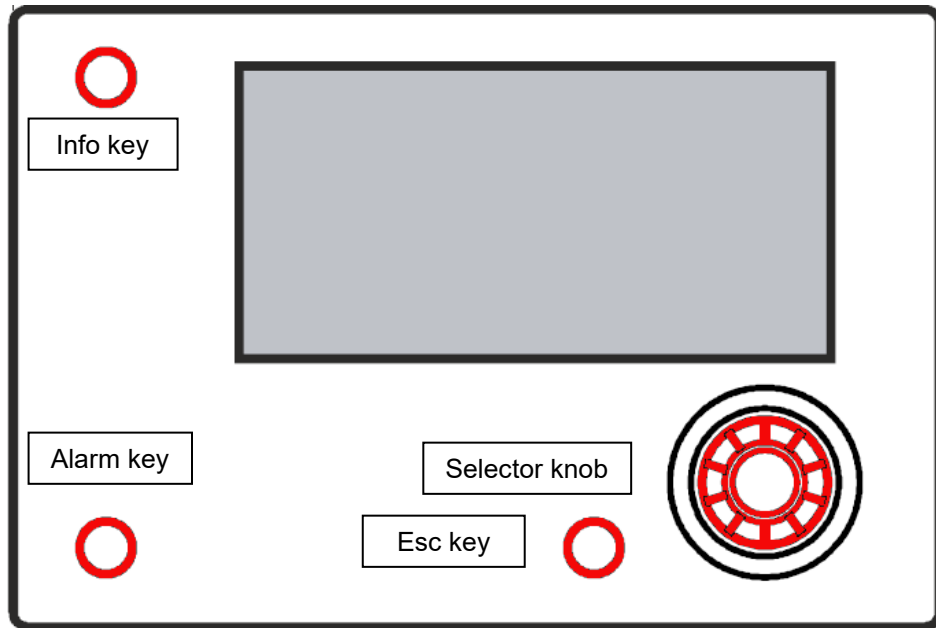

Figure 1 POL895

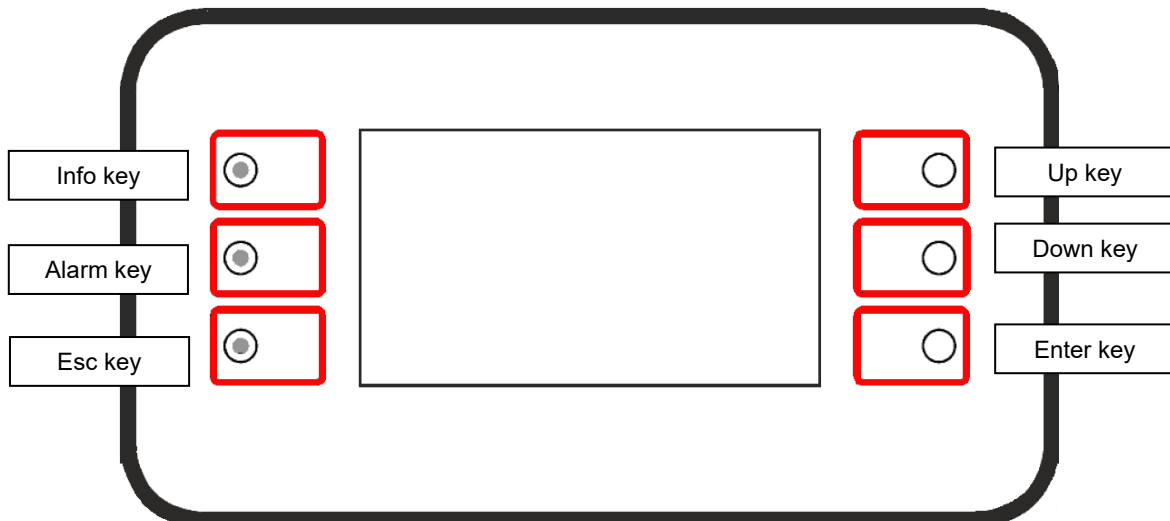

Figure 2 POL 871

3.2.3 Web interface

HMI is also available through web interface using the IP address shown in About unit page, a web interface password is required to access it

- Both POL 895 and 871 are optional, which allow navigation through the application pages, the available data can change, the LCD shows additional data to configure optional items such as BMS configuration, some of the additional values are protected with different level passwords to prevent wrong parameterizations to unauthorized users.
To select the access level the user must click on login rectangle (web interface) or push knob in POL895 or Enter key in POL871.

3.3. Password

Different levels of password are available in the application; at each level different parameters are accessible. Summary of password and access level in the table below

Level name	Level index	Password
End user	--	--
User	6	5321
Maintenance	4	2526

HMI Path: Main page → Settings → Enter Password

To access password input page, select “Settings” from main menu as shown below:

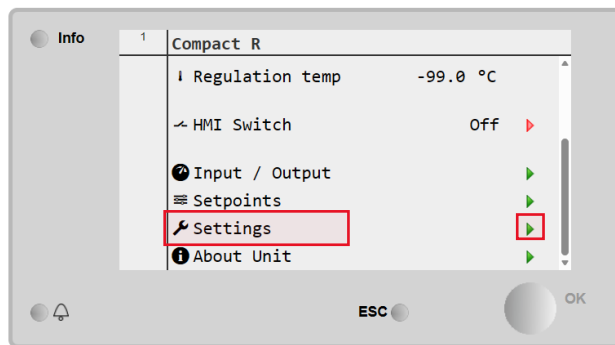

Select “Enter Password” to show menu with “Login”

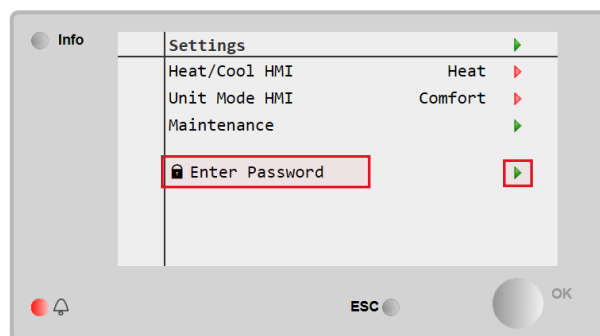

Select “Entry” and use the needed value as reported in table at the beginning of the chapter.

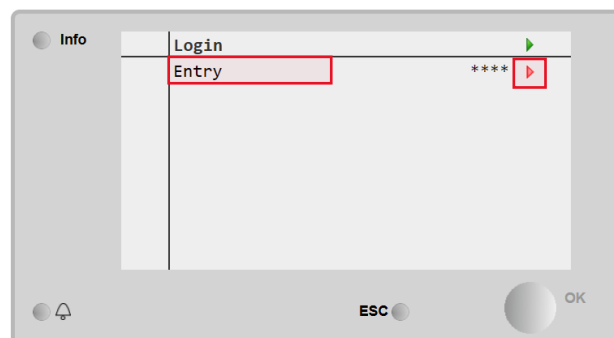

4. Control Functions

This section describes the main control functions available in Daikin Compact R Air Handling Units.

The activation sequence of the devices installed in Daikin AHU for thermoregulation control is shown below.

- On the Base Unit the fans will be free to start immediately, while if you have dampers the fans will wait for the minimum opening before starting.
- Fan speed is monitored with an algorithm that evaluates the differential pressure by reading the pressure difference between the zone before the fan and the fan impeller. This placement allows us to control the machine in constant airflow; the system adjusts the fan speed to reach the setpoint and keep it as stable as possible.
- While reaching the setpoint the system will start treating the air with the heat recovery unit.
- If coils are present, the algorithm will start the control loops on Temperature and/or Humidity to meet the demand.

Treatment control can be done on the supply temperature or the return temperature.

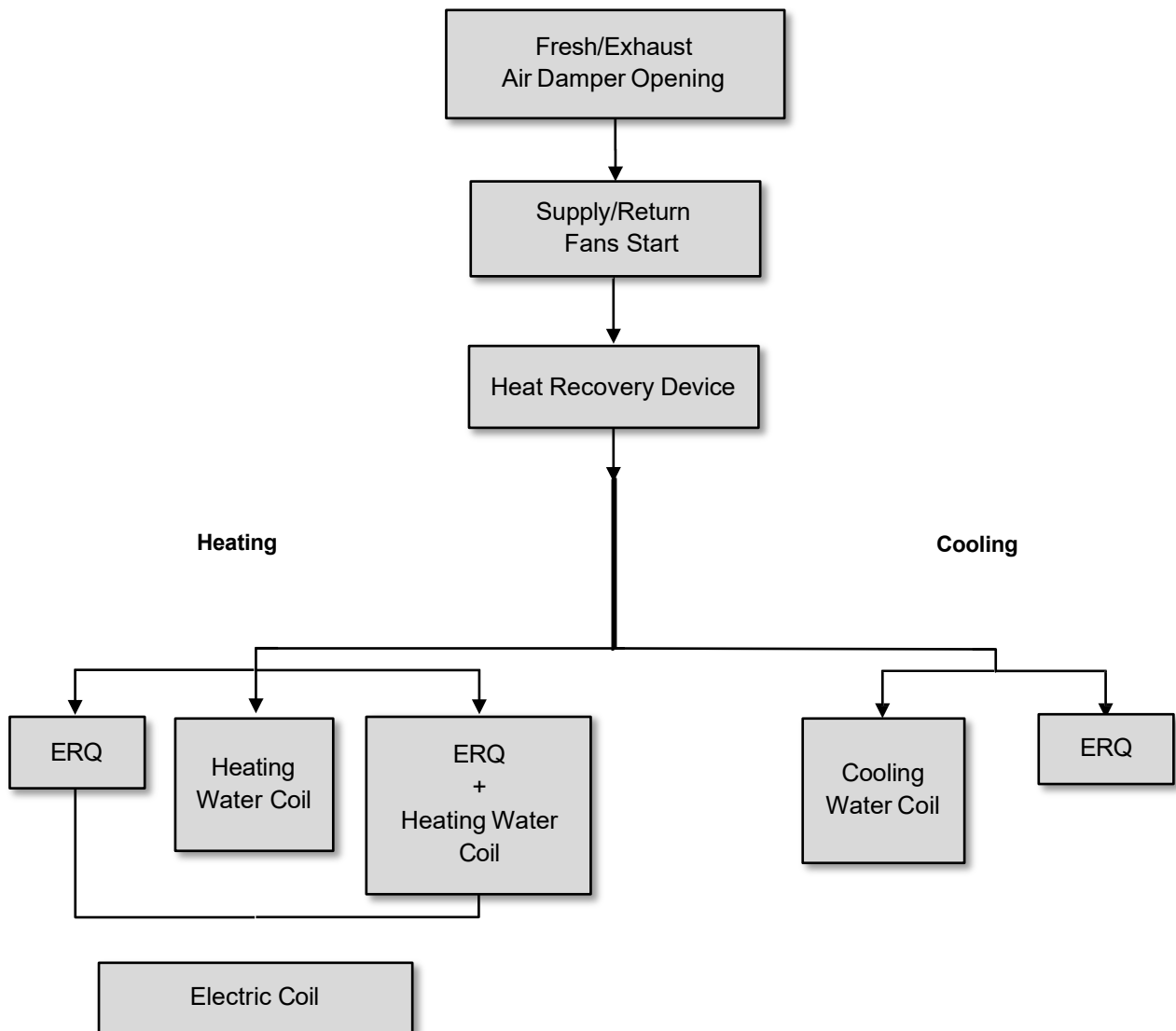

The starting sequence is performed according to an energy saving management logic, in order to satisfy the desired temperature setpoint.

5. Configuration pages

For activation of the various components go, after putting the password in Settings, to the AHU Configuration, Unit Configuration, Config Components, Config Status and Config Function.

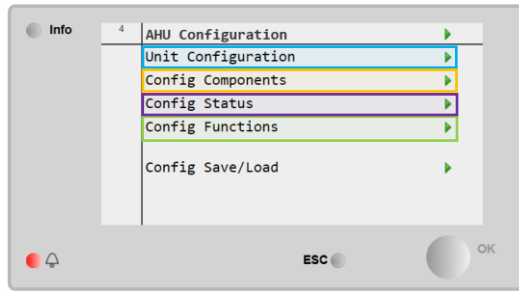

5.1. Unit Configuration

To access the Unit Configuration page these steps must be followed

Password level : [\(Maintenance Level\)](#)

HMI Level: Main page → Settings → AHU Configuration → Unit Configuration.

5.2. Configuration Components

To access the Configuration Components page these steps must be followed

Password level : [\(Maintenance Level\)](#)

HMI Level: Main page → Settings → AHU Configuration → Config Components.

5.3. Configuration Status

To access the Configuration Status page these steps must be followed

Password level : [\(Maintenance Level\)](#)

HMI Level: Main page → Settings → AHU Configuration → Config Status.

5.4. Configuration Functions

To access the Configuration Functions page these steps must be followed

Password level : [\(Maintenance Level\)](#)

HMI Level: Main page → Settings → AHU Configuration → Config Functions.

5.5. Restart

Remember to go to the "Restart required!" item after you have made all the changes to each individual menu.

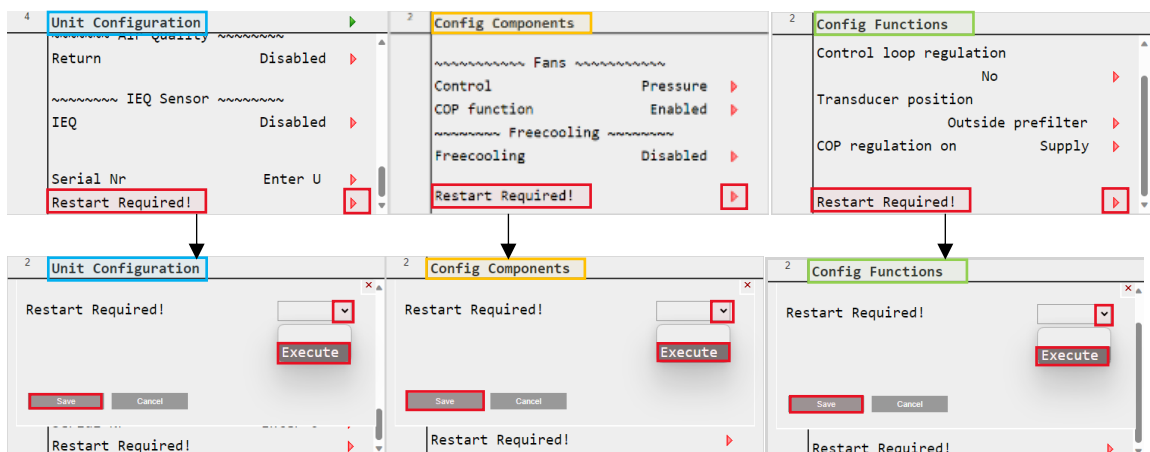

You can also restart with each individual change for each menu.

6. Configuration

6.1. Heat/Cool HMI

The user can choose in which mode the unit works from the Settings page if the precedence of Heat/Cool is on HMI

- HEAT (refers to heating mode)
- COOL (refers to cooling mode)

HMI Path: Main page → Settings → Heat/Cool HMI (No password is needed)

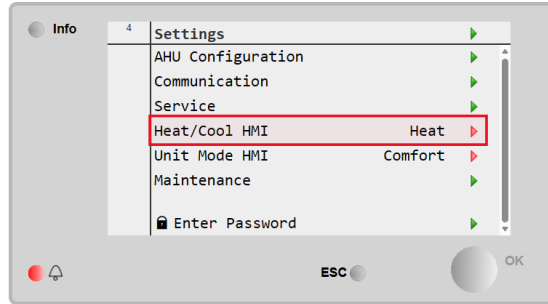

Notice that:

- Each mode has its own setpoints, for more information refers to [Setpoint chapter](#).
- The Heat/Cool mode can be chosen in different ways, check the [Precedence – Heat/Cool](#)

6.2. Comfort/Eco/Boost HMI

The user can choose in which mode the unit will work if the precedence of Comfort/Economy is on HMI and BMS is disabled

- Comfort (refers to comfort mode)
- Economy (refers to economy mode)
- Boost (refers to boost mode)

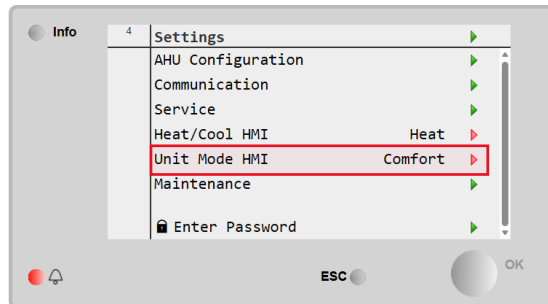

- Each mode has its own setpoints, for more information refers to [Setpoint chapter](#).
- The Comfort/Economy/Boost mode can be chosen in different ways, check the [Precedence – Comfort/Economy/Boost](#)

6.3. Comfort/Economy switch

Comfort/economy switch can be enabled in Unit Configuration page, once enabled the user can switch between

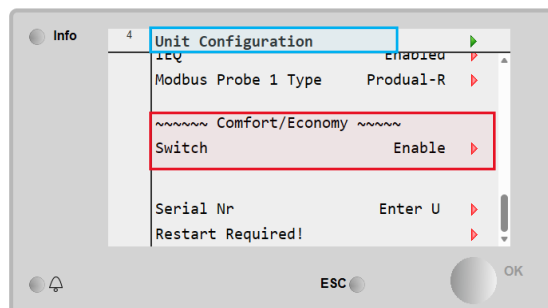

comfort and economy mode using the 2X7 – X switch

- Each mode has its own setpoints, for more information refers to [Setpoint chapter](#).
- The Comfort/Economy/Boost mode can be chosen in different ways, check the [Precedence – Comfort/Economy/Boost](#).

6.4. Precedence

6.4.1 Heat/Cool

The user can choose how to select the Heat/Cool mode by one of the following ways

- HMI
- Panel Switch (DI2 on POL688)
- BMS
- Outdoor Temperature (Based on the active outdoor temperature)
- Regulation Temperature (Based on the active regulation temperature)

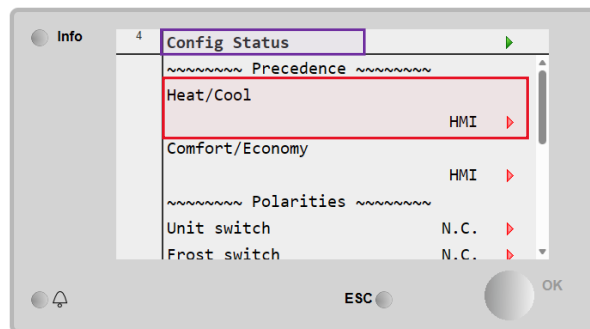

- Outdoor and regulation temperature ways are based on the cooling/heating threshold.
 - If outdoor/regulation temperature is more than the **Heating Threshold** for **(Changeover Time setpoint)** minutes, then the unit changes to heating mode
 - If outdoor/regulation temperature is less than the **Cooling Threshold** for **(Changeover Time setpoint)** minutes, then the unit changes to cooling mode

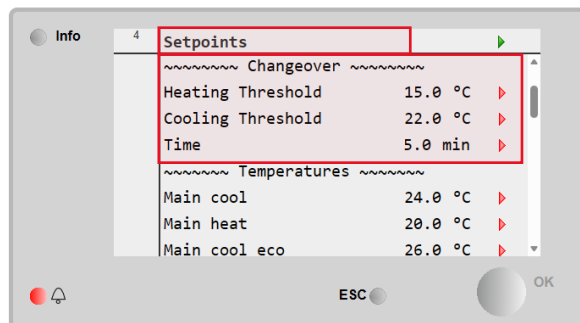

6.4.2 Comfort/Economy

If the Comfort/Economy Switch is enabled, then the user can choose how to select the comfort/economy/boost mode

- HMI (BMS if BMS is enabled)
- Switch (if switch is selected, the boost mode is not available)

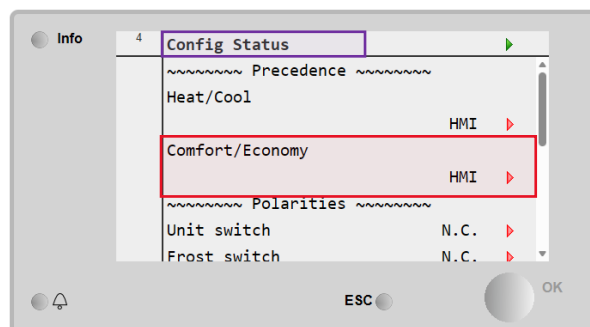

6.5. Regulation

6.5.1 Main probe

The main probe position can be changed as follows:

- In [Unit Configuration page](#)
- Regulation section – Main probe

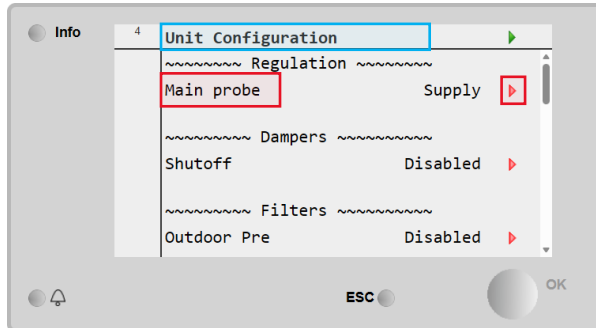

Indicate which probe is used for regulation: Supply or Return.

Notice that:

- The supply probe is connected to X10
- The return probe is connected to X11
- These probes are NTC10k type

6.5.2 Dynamic supply setpoint

If the main probe is connected to the Return the user will have the possibility to change the dynamic setpoint of the supply temperature in the configuration function which can be selected from the following options

- **Supply setpoint limit**
(The supply will be regulated based on the return setpoint with respect to a maximum and minimum range that can be set in [Setpoints page](#) (Supply min, Supply max))
- **Return setpoint offset**
(The supply will be regulated based on the return setpoint with respect to an offset that can be set in [Setpoints page](#) (Offset Supply))
- **Return Temperature offset**
(The supply will be regulated based on the return regulating temperature with respect to an offset that can be set in [Setpoints page](#) (Offset Supply))

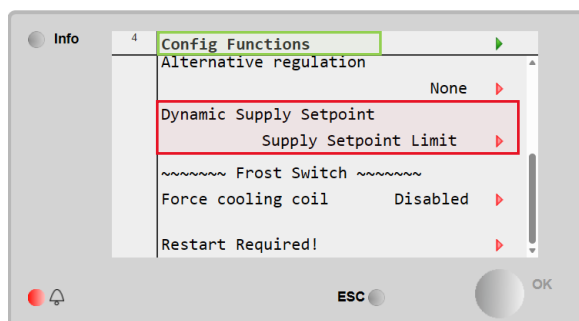

6.6. Room Unit

The user can enable IEQ and Proidual-RTX-D if available, in [Configuration Configuration page](#) – Room section

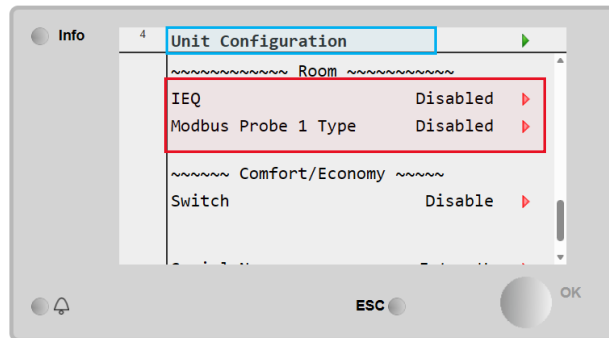

Once enabled the Proidual-RTX-D, the available Proidual-RTX-D sensors can be enabled in [Configuration Component page](#) – Room section

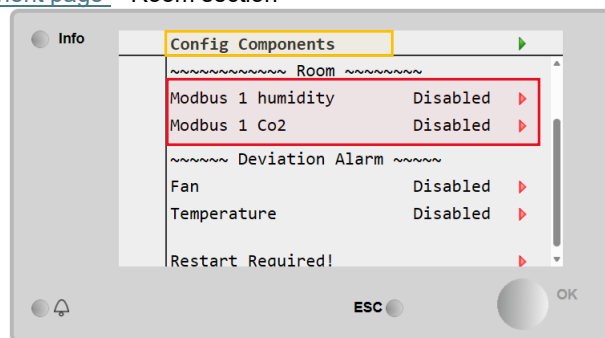

6.6.1 Regulation probe

If the [Main probe](#) is on the Return and the Room temperature is enabled the user has in [Configuration Function](#) page – Temperature section the option to choose on which probe to regulate

- Return temperature probe
- Room temperature probe

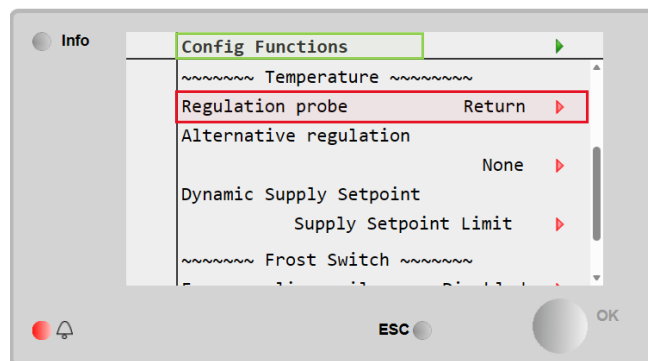

An alternative regulation is also available if the user wants to use the supply probe as an alternative regulation probe in case of failure of both the return and room probes

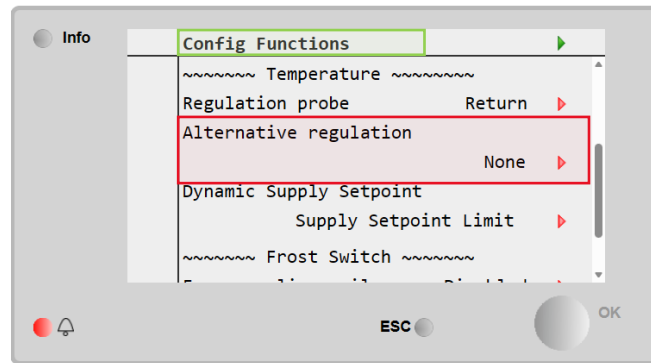

- Notice that: The regulation probe is chosen in the following way
 - **Main Regulation Probe: Return** and
Regulation probe: Return
 - **Alternative regulation: NO**
 1. Return probe (if not in alarm)
 2. Room probe (if enabled and not in alarm)
 - **Alternative regulation: Supply probe**
 1. Return probe (if not in alarm)
 2. Room probe (if enabled and not in alarm)
 3. Supply probe (if not in alarm)
 4. Supply optional probe (if available and not in alarm)
 - **Main Regulation Probe: Return** and
Regulation probe: Room
 - **Alternative regulation: NO**
 1. Room probe (if not in alarm)
 2. Return probe (if not in alarm)
 - **Alternative regulation: Supply probe**
 1. Room probe (if not in alarm)
 2. Return probe (if not in alarm)
 3. Supply probe (if not in alarm)
 4. Supply optional probe (if available and not in alarm)
 - **Main Regulation Probe: Supply**
 1. Supply probe (if not in alarm)
 2. Supply optional probe (if available and not in alarm)

6.7. Fans

6.7.1 Control loop regulation

In the [Configuration Functions](#), you can choose the regulation type for the fan control loop, which adjusts the minimum and maximum flow setpoint limits of the fans.

There are three modes:

- **Temperature Regulation**
(The fans will regulate within the new flow setpoint limits based on the temperature sensor)
- **CO₂ Regulation**
(The fans will regulate within the new flow setpoint limits based on the air quality sensor)
- **Temperature + CO₂ Regulation**
(The fans will regulate within the new flow setpoint limits based on both the temperature and air quality sensor)

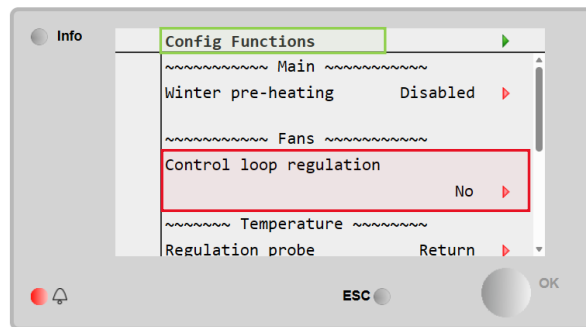

Notice that: The new flow setpoint limits can be set in the [Setpoints page](#) – Fans section

- Supply flow minimum (comfort/economy/boost)
- Supply flow maximum (comfort/economy/boost)
- Return flow minimum (comfort/economy/boost)
- Return flow maximum (comfort/economy/boost)
- If the COP function is enabled, then the available setpoint are
 - Supply/Return Pressure minimum (comfort/economy/boost)
 - Supply/Return Pressure maximum (comfort/economy/boost)

6.7.2 COP Function

In the [Configuration Components](#) – Fans section, COP (Control of Pressure) function can be enabled (Be aware that COP Function requires a transducer pressure on supply/return connected to [X6B -Y terminal](#))

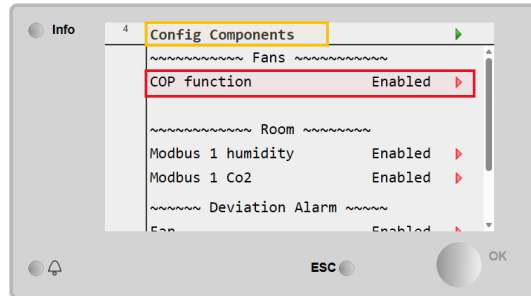

Once enabled in [Configuration Functions](#) the user can choose what the COP will regulate on (Supply or Return).

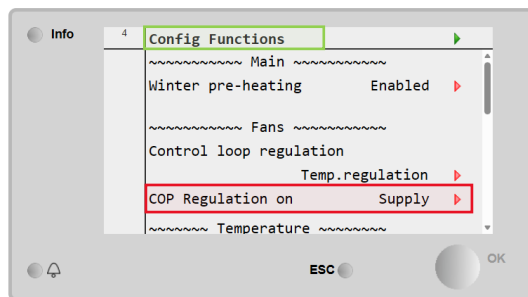

Notice that: Regulating the COP on the

- **Supply:** The supply fan is regulated based on the supply pressure setpoint, while the return fan is controlled proportionally to the supply airflow, using a return flow factor
(*Supply pressure, Supply pressure economy/boost, Return flow factor*) can be modified in [Setpoints page](#) – Fans section
- **Return:** The return fan is regulated based on the return pressure setpoint, while the supply fan is controlled proportionally to the return airflow, using a supply flow factor
(*Return pressure, Return pressure economy/boost, Supply flow factor*) can be modified in [Setpoints page](#) – Fans section
- If the control loop regulation function is also enabled, then the setpoints becomes with minimum and maximum range

6.8. Dampers and filters

6.8.1 Outdoor and Exhaust air dampers

Dampers can be enabled if available in [Unit configuration](#) page – Dampers section

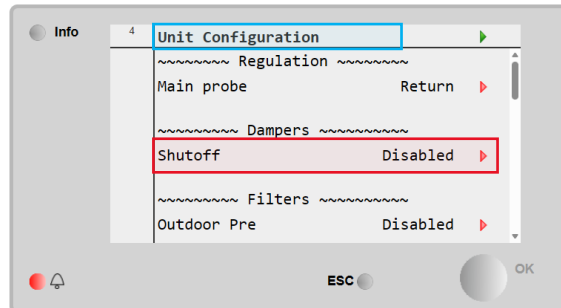

Which allows exclusion of AHU from direct and coming from outdoor ducts. Connect Shutoff Damper on pin X2.1 on terminal Y.

Notice that: Enabling the shutoff damper introduces a fixed time delay before fan startup to ensure the damper is fully open prior to operation (~ 150 sec)

6.8.2 Supply and Return air filters.

Supply and return filters can be enabled if available in [Unit configuration](#) page – Filters section

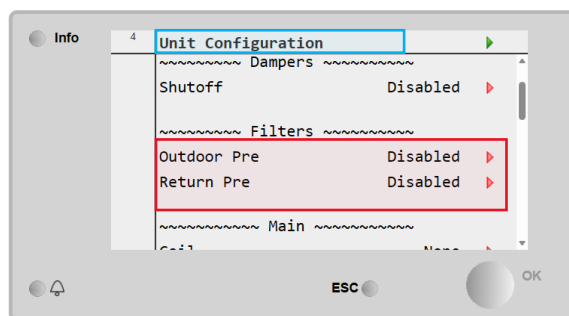

6.9. Coils

There are different types of coils which all can be enabled in [Unit configuration](#) page – Pre, Post, Main sections

6.9.1 External Pre-heating coil

This Coil can be either Electric or Water, it is used to raise the inlet temperature of the AHU before the heat recovers.

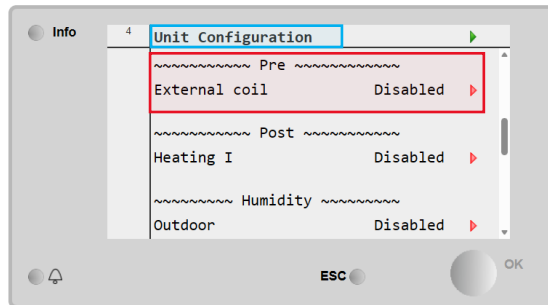

It can be enabled in [Unit configuration](#) page – Pre section

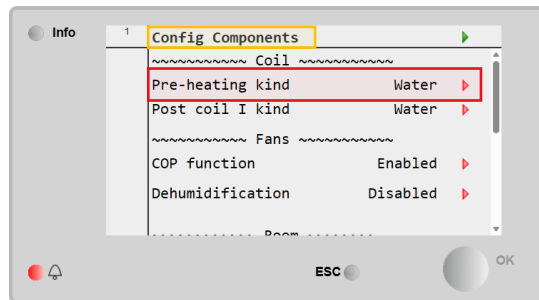

Its type can be selected in [Configuration Components](#) page – Coil section

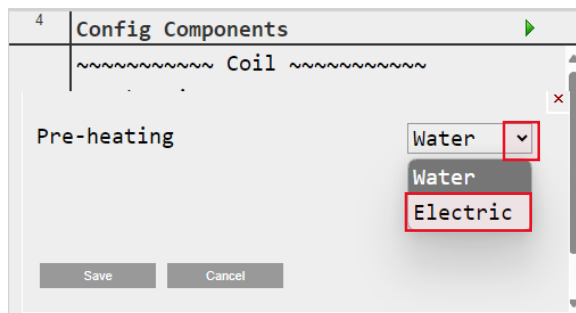

Notice that: When selecting Electric Pre-heat, you need to install an additional Outdoor temperature sensor on the duct before the Pre-heat coil on [X1B on -Y](#)

6.9.2 ERQ Main coil

The Main coil can be either ERQ or Water, and it can be enabled in [Unit Configuration](#) – Main section, and if it's in cooling or heating/cooling mode then it requires a [Temperature Supply Optional](#) transducer connected to the [X7A -Y](#).

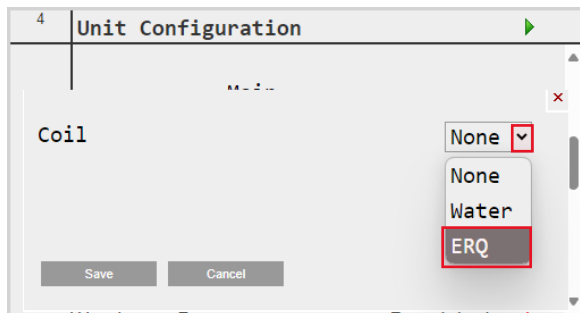
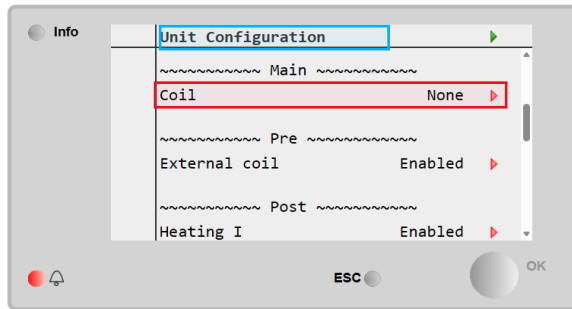

- ERQ Main coil

If the main coil is ERQ, the EKE box kind from the [Configuration Components](#) page – Coil is available

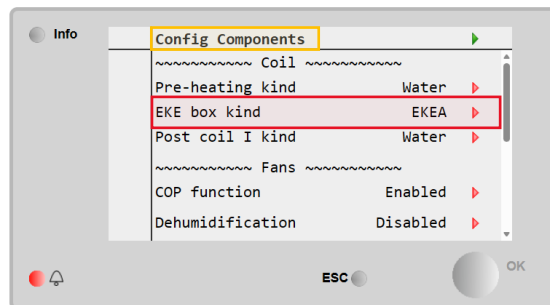

For DX solution, it provides the installation of our ERQ, maximum one circuit.

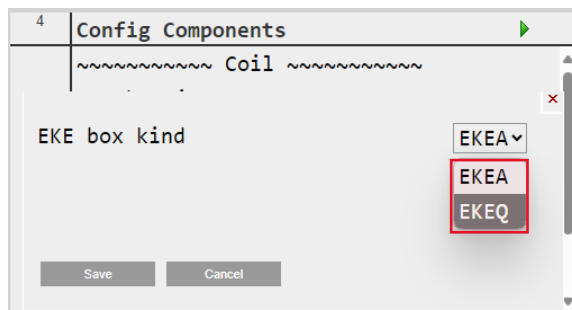

6.9.3 Water Main coil

For the water solution through the software, you can decide whether to have a heat only, cool only or a combined water coil in [Configuration Function](#) page – Coil section

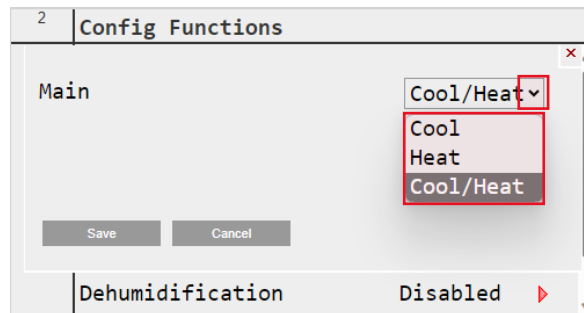
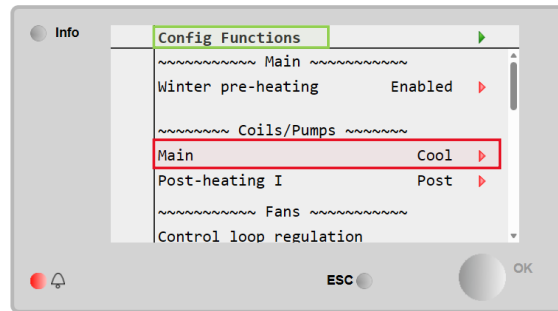

6.9.4 Post Heating I Coil

It can be enabled in [Unit Configuration](#) page – Post section

Notice that:

- Post Heating coil can be either water or electric and has different function modes.
- The post heating 1 requires a [Temperature Supply Optional](#) sensor connected to the [X7A -Y](#).

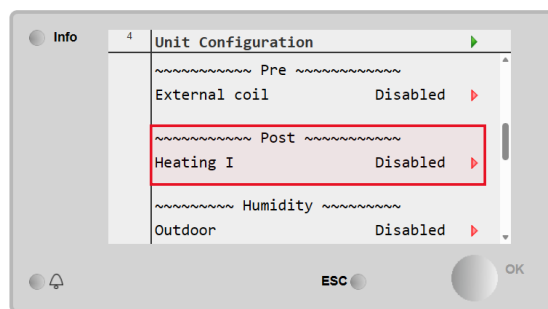

The kind of the Post heating coil I can be selected in [Configuration Components](#) page – Coil

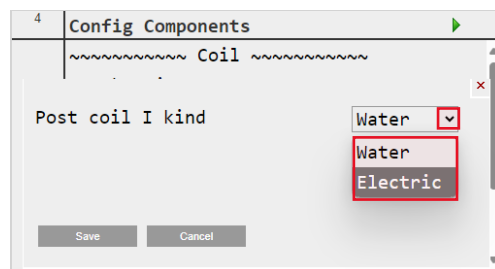
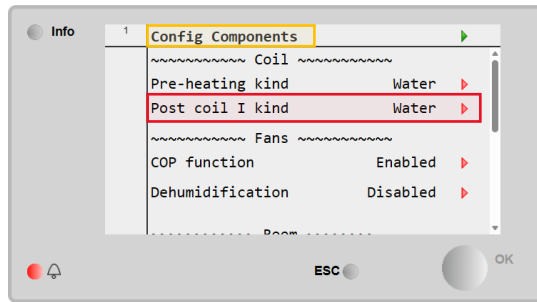

The function mode of the Post heating coil I can be selected in [Configuration Functions](#) page – Coil

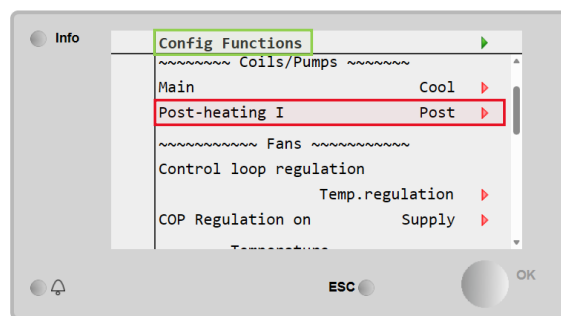

Notice that:

The user can select the function to be

- Post à To let the heating occur after the dehumidification
- Heat à To let the heating occur if the main coil is not able to reach the set point
- Post / Heat à To have both functionality

6.10. Filters

Outdoor and/or return pre-filters can be added to the unit. However, a pressure transducer is required to monitor the pressure differential and trigger an alarm if necessary.

6.10.1 Outdoor air Pre-filter

If the Outdoor Pre-filter is available, pressure transducer should be connected to pin [X1A - Y](#)

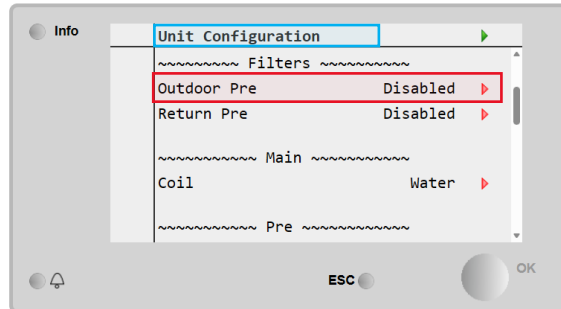

6.10.2 Return air Filter.

If the Return Pre-filter is available, pressure transducer should be connected to pin [X5B - Y](#)

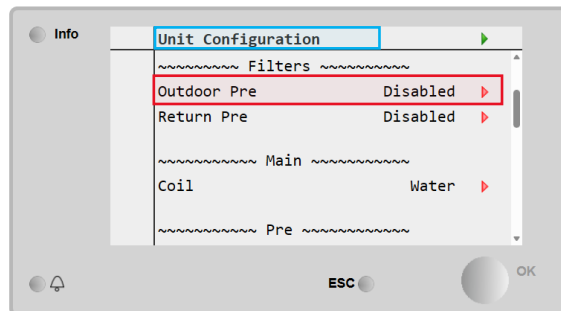

6.11. Status

In [Configuration Status](#) page different configuration can be changed

6.11.1 Polarities

Polarities of the Fire Alarm, Unit Switch and Frost switch can be changed to ((N.C.) Normally Closed // (N.O.) Normally Open)

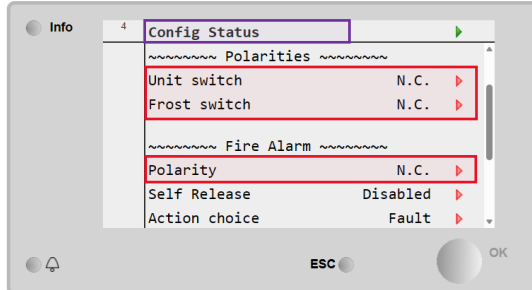

6.11.2 Self-Release

The self-releasing alarm of the Fire Alarm can be Enabled/Disabled

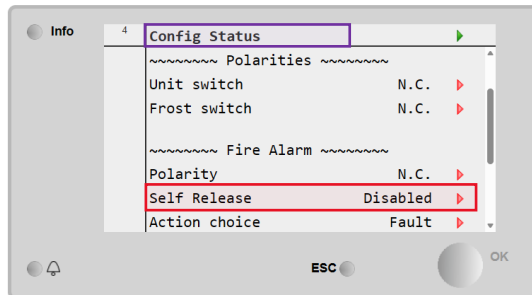

6.11.3 Alarm action choice

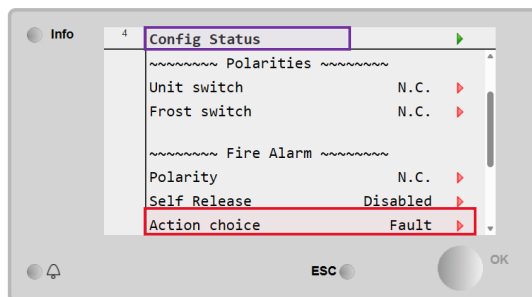

- Alarm Type Selection for Fire Alarms:
 - **Fault** (*Default, as in previous versions*): The unit will stop operating in the event of a fire alarm.
 - **Warning**: The unit will continue operating. Fans will regulate according to **user-defined flow/pressure setpoints**.

If **Warning** has been selected as Action choice for fire alarm, then in [Configuration Functions](#) page – Fan Setpoint section the Fire choice option is available

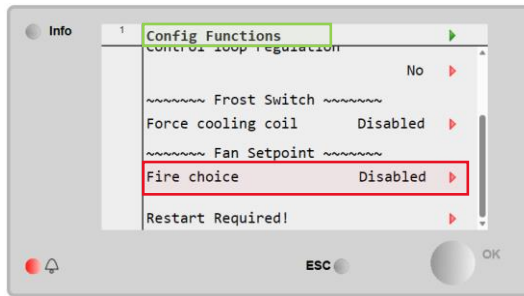

- Custom flow setpoints for **Warning** mode in Fire mode:
 - When **Active** is selected as the fire alarm type, users can define **new airflow/pressure setpoints** in [Setpoints page](#) – Fans section that the unit will use to regulate fan speeds during a fire alarm event.
 - When **Null** is selected no changes in airflow/pressure setpoints will occur

6.11.4DO Logic

6.11.4.1. Global Alarm

The Global Alarm output activates when the user-selected alarm level is triggered:

- Danger
- Fault
- Warning
- Maintenance

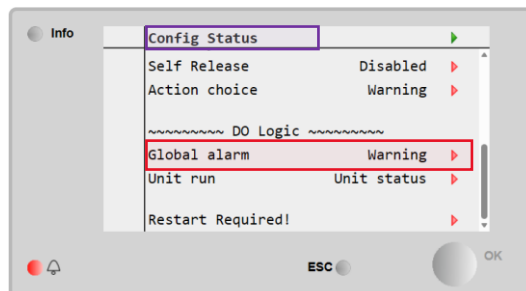

6.11.4.2. Unit Run

In Configuration Status, Unit Run can be chosen based on (Unit or Fans) Status.

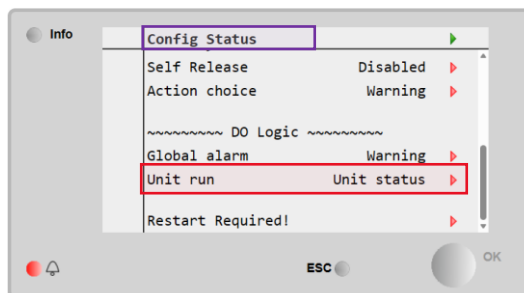

6.12. Serial Number

The user has the possibility to add the Serial Number in the [Unit Configuration](#).

Unit Configuration		
Return	Enabled	▶
~~~~~ IEQ Sensor ~~~~~		
IEQ	Enabled	▶
Serial Nr	000000	▶
Restart Required!		

## 6.13. Optional POL955 A/B (OPTIONS)

The optional POL955 A/B are used to manage some components that can be added to the unit configuration.

### 6.13.1 Optional POL955 A

The Components in POL955 A are:

POL955 OPTION A		
EKEA	Error status	X4A on -X
	R32 Alarm	X5A on -X
	Input ON/OFF	Q13A/Q14A on -X
	Cool/Heat status	Q23A/Q24A on -X
	Malfunction Low flow	Q33A/Q34A on -X
	0-10 DC	Y1A on -X
Post Heating	Supply Air Temperature (Electric/ Water Coil Pump) Alarm	X7A on -Y X8A on -X
	(Electric/ Water Coil Pump) ON/OFF	Q43A/Q44A on -X
	(Electric/ Water Coil Pump) Signal	Y2A on -X
Return Air	CO2	X2A on -X
	Humidity	X3A on -X
DPT	Outdoor Air Prefilter	X1A on -Y
Water Coil	(Cooling/Heating/Cooling-Heating) Alarm	X4A on -X
	(Cooling/Heating/Cooling-Heating) ON/OFF	Q13A/Q14A on -X
	(Cooling/Heating/Cooling-Heating) Signal	Y1A on -X

#### 6.13.1.1. R32

If the [Main coil is ERQ](#) is present, a R32 enabling option is available in [Configuration Function](#) page

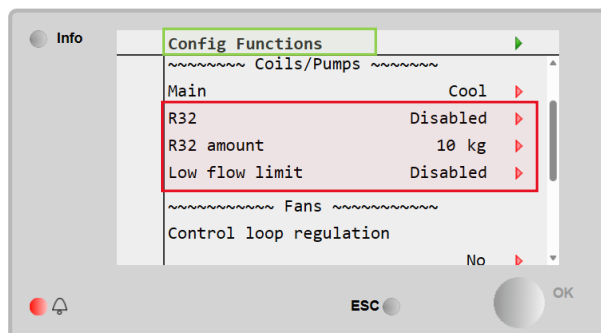

Notice that:

- R32 alarm is connected to X5A on terminal X

- If enabled the Low Flow Alarm is triggered when the calculated threshold (which is obtained by multiplying the configured R32 amount by a fixed factor) is lower than the actual flow supply for a continuous duration of 5 seconds (or 120 seconds during startup).

### 6.13.1.2. Return air humidity

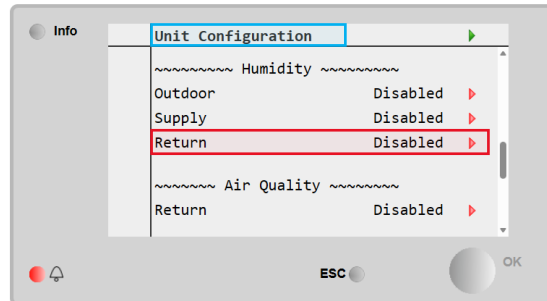

If available, connect the Return Humidity probe to pin X3A on terminal X and enable it in [Unit Configuration](#) page – Humidity section

Notice that:

- The dehumidification is available in the presence of the Post-Heating and the Return humidity probe, in the [Configuration Components](#) page – Humidity section

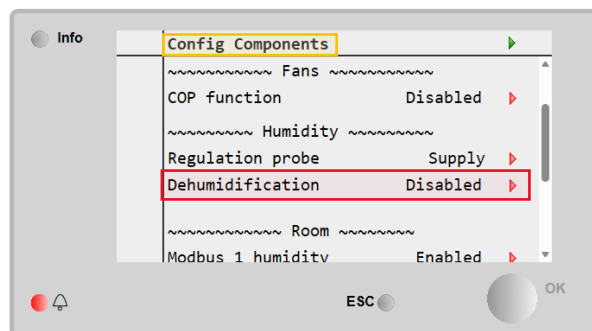

### 6.13.1.3. CO2 probe

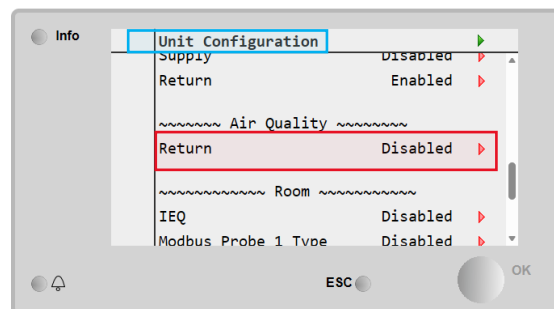

If available, connect the CO2 probe to pin X2A on terminal X

### 6.13.2 Optional POL955 B

The Components in POL955 B are:

POL955 OPTION B		
<b>Pre-Heating</b>	Outdoor Air Temperature if Preheater is present	X1B on -Y
	(Electric/ Water Coil Pump) Alarm	X4B on -X
	(Electric/ Water Coil Pump) ON/OFF	Q14B on -X
	(Electric/ Water Coil Pump) Signal	Y1B on -X
<b>DPT</b>	Return Air Prefilter	X5B on -Y
	Supply/Return Duct pressure control	X6B on -Y
<b>Comfort Economy</b>	-	X7B on -X
<b>Humidity</b>	Outdoor Air	X2B on -X
	Supply Air	X3B on -X

#### 6.13.2.1. Outdoor air humidity

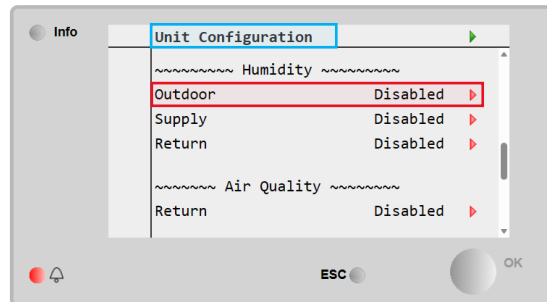

If available, connect the Outdoor Humidity probe to pin X2B on terminal X

#### 6.13.2.2. Supply air humidity

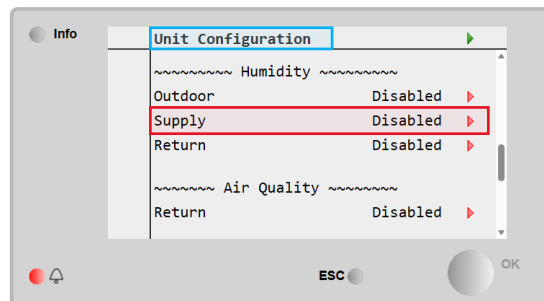

If available, connect the Supply Humidity probe to pin X3B on terminal X

### 6.13.2.3. IEQ Sensor

Enabling the IEQ Sensor in [Configuration Unit](#) shows its parameters in [Analog Inputs](#) Interface.

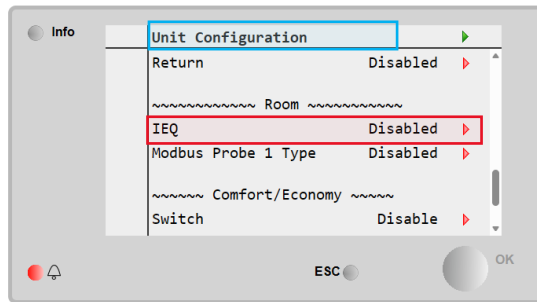

## 6.14. Other Function

### 6.14.1 AHU General Alarm

Free changeover contact to remote the alarm status of the unit.

### 6.14.2 AHU Run

Free changeover contact to have an enabling.

### 6.14.3 Cool/Heat Status (Output)

Free contact that changes depending on the type of treatment of the unit.

### 6.14.4 Fire Alarm

Connection for a possible fire detection component.

### 6.14.5 Comfort/Economy

Provision for a switch to change all set points (must have set comfort set points).

### 6.14.6 Fan deviation alarm

A deviation alarm is triggered when a measured pressure/airflow drifts outside of a pre-set range relative to its desired setpoint

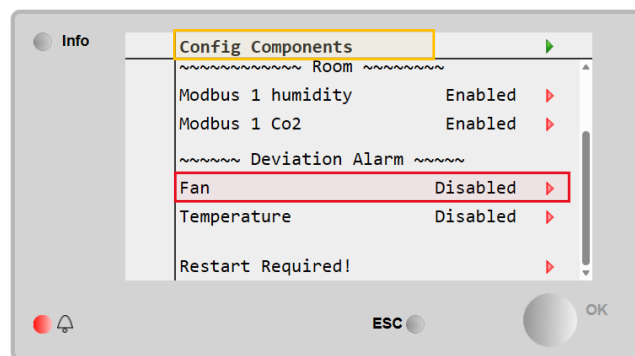

### 6.14.7 Temperature deviation alarm

A deviation alarm is triggered when a measured supply/return temperature drifts outside of a pre-set range relative to its desired setpoint

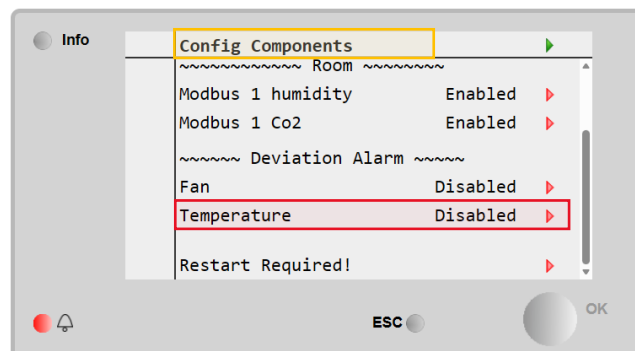

#### 6.14.8 Unit Enable Switch

Provision for a remote switch to enable the unit.

#### 6.14.9 Supply Temperature optional

Having main or/and post heating I, makes the regulation on the supply temperature optional:

- Main
    - Heating → Supply Temperature Optional
    - Cooling → Supply Temperature Optional
    - Heating/Cooling → Supply Temperature Optional
  - Post I → Supply Temperature Optional
    - However, if the Supply Temperature Optional is in alarming, then:
      - Main
        - Heating → OFF
        - Cooling → OFF
        - Heating/Cooling → OFF
      - Post I → OFF
- Notice that: Having the Supply Temperature Optional available will change the alarming of the Supply Temperature from fault to warning.  
And if both supply temperature and supply temperature optional are in alarm the unit goes in fault alarm.

#### 6.14.10 Humidity regulation probe

If both return and supply humidity are enabled, then in [Configuration Functions](#) page – Humidity section, the user can select the regulation probe of humidity to be on supply or return

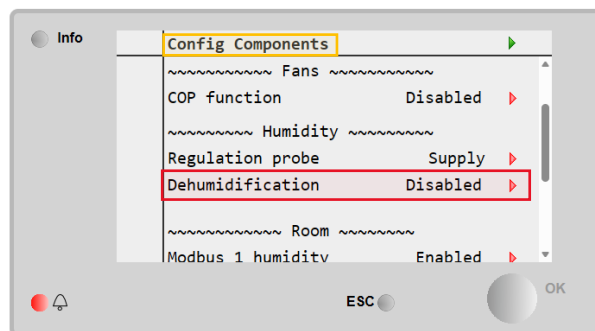

#### 6.14.11 Cool/Heat Status (Input)

Provision for a switch to change the type of treatment of the unit.

### 6.14.12 Winter pre-heating

Enabling the winter pre-heating is available in Configuration Functions page.

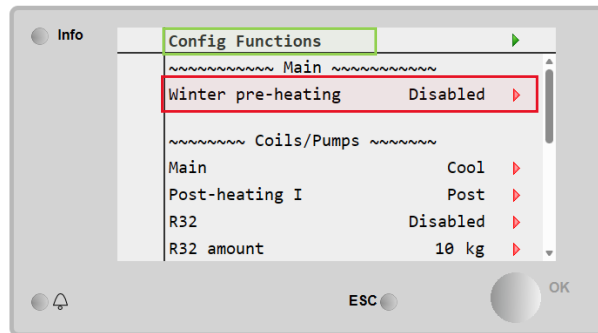

If the outdoor temp is less than the winter pre-heating temp, pre-heating mode is activated in the following conditions at start up for a specific time (winter pre-heating time)

#### Pre-heating mode

- With water coils only
  - Water coil starts regulating
  - Fans/Dampers closed
  - 'Pre-heating' text is displayed in Actual status
- With electrical coils only
  - Normal start up (Fans/Dampers/coils start regulating)
  - NO string of pre-heating is displayed
- With DX coil
  - Dampers open
  - Fans run at minimum flow setpoint (Low flow alarm setpoint + 5%)
  - DX Coil starts regulating
  - 'Pre-heating' text is displayed in Actual status
- With water and electrical coils
  - Electric coil is off
  - Water coil starts regulating
  - Fans/Dampers closed
  - 'Pre-heating' text is displayed in Actual status
- With DX coil and electrical coil
  - Electric coil is off
  - Dampers open
  - Fans run at minimum flow setpoint (Low flow alarm setpoint + 5%)
  - DX Coil starts regulating
  - 'Pre-heating' text is displayed in Actual status
- With DX coil and water coil
  - Water coil
  - Dampers open
  - Fans run at minimum flow setpoint (Low flow alarm setpoint + 5%)
  - DX Coil starts regulating
  - 'Pre-heating' text is displayed in Actual status
- In running mode (after end of the pre-heating mode)
  - All coils start regulating
  - Dampers open
  - Supply fan runs

## 7. Main Menu screen

The unit is sold without its own on-board interface. the parameters can be accessed in various ways, via web interface if the unit is connected to the network, via Pol 895 with which you have the possibility to access the various menus of the AHU depending on the password entered and with AUC00RT which it only allows you to read the temperature of the environment where it is installed, turn the AHU ON/OFF, change the temperature set point and change the hot/cold status of the unit (if set by the HMI on the control).

### 7.1. LCD/Web interface

Through Main Menu screen the user can read the main important information necessary for monitoring the AHU status. In particular, the user can:

- Control the AHU status
- Read main values
- Switch unit Off/On
- Change the AHU Setpoint
- Access to the I/O overview menu
- Access settings
- About Unit
- Restore alarm conditions

Next chapters will describe any item of the main menu. In the following table the user can find all the items of the main menu screen and the section where it is described.

Main Menu item	Section
<b>Actual status</b>	Display the actual status of the AHU. <a href="#">(Chapter 8)</a>
<b>Mode</b>	Display the type of treatment Cool or Heat <a href="#">(Chapter 9)</a>
<b>Regulation values</b>	Display actual supply, return temperature used to regulate treatment system. <a href="#">(Chapter 10)</a>
<b>HMI switch</b>	Change the unit status from OFF to On and vice versa. <a href="#">(Chapter 11)</a>
<b>Input/Output</b>	Allow user to access the menu that shows all the input/output values of the AHU. <a href="#">(Chapter 12)</a>
<b>Setpoints</b>	Allow user to access the menu that shows unit setpoints. <a href="#">(Chapter 13)</a>
<b>Settings</b>	Allow the user to access the menu that shows all unit settings (up to the password input). <a href="#">(Chapter 14)</a>
<b>About unit</b>	Allow the user to access information about the control system of the AHU. <a href="#">(Chapter 16)</a>
<b>Restore alarm condition</b>	Allow the user to reset alarms once the problem is fixed. <a href="#">(Chapter 17)</a>

## 8. Actual status

This item displays the actual status of the AHU. All possible statuses are reported in the table below.

**HMI Path: Main page → Actual status**

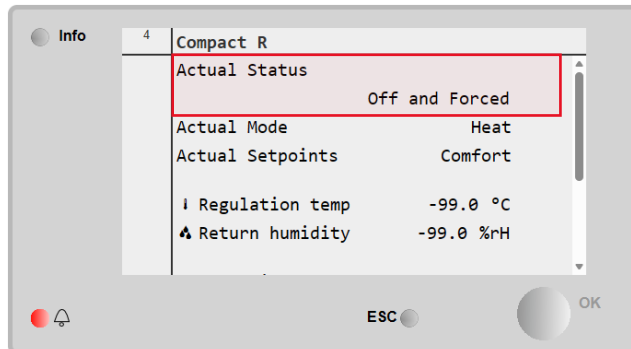

Main Menu item	Value	Description
<b>Actual status</b>	<ul style="list-style-type: none"> <li>- Off by fire alarm</li> <li>- Off by alarm</li> <li>- Off by DI switch</li> <li>- Off by BMS</li> <li>- Off by Scheduler</li> <li>- Off and forced</li> <li>- Off</li> <li>- Post ventilation</li> <li>- Forced</li> <li>- On</li> <li>- On by BMS</li> <li>- On by scheduler</li> <li>- Ventilation</li> <li>- Ventilation by BMS</li> <li>- Ventilation by Scheduler</li> <li>- Pre-heating</li> </ul>	<ul style="list-style-type: none"> <li>- <b>Off by Fire alarm:</b> Highest priority alarm, the unit is switched off immediately due to fire alarm.</li> <li>- <b>Off by Alarm</b> Unit is switched off due to (Fault) alarms which doesn't allow the system to work in safety condition.</li> <li>- <b>Off and Forced</b> Unit is switched off due to alarms that doesn't allow the system to work in safety condition however, the coils are forced due to frost alarm.</li> <li>- <b>Off by DI Switch</b> The unit is switched off by the selector on the electrical panel.</li> <li>- <b>Off by BMS</b> The unit is switched off by BMS command.</li> <li>- <b>Off by Scheduler</b> The unit is switched off by Scheduler command.</li> <li>- <b>Off</b> The unit is switched off by HMI command</li> <li>- <b>Post ventilation</b> The unit is turned off, and the fans are running to a fixed value due to electrical coil</li> <li>- <b>Forced</b> The unit is switched on, and the coils are forced due to frost alarm</li> <li>- <b>On</b> The unit is switched on and operational</li> <li>- <b>On by BMS</b> The unit is switched on by BMS command.</li> <li>- <b>On by Scheduler</b> The unit is switched on by Scheduler command.</li> <li>- <b>Ventilation</b> The unit is in ventilation mode</li> <li>- <b>Ventilation by BMS</b> The unit is in ventilation mode by BMS command</li> <li>- <b>Ventilation by Scheduler</b> The unit is in ventilation mode by Scheduler command</li> <li>- <b>Pre-Heating</b> The unit is in pre-heating mode</li> </ul>

On status follows a priority chain according to the following table:

HMI Switch	Panel Switch	BMS Enabled	BMS	Scheduler Enabled	Scheduler	Unit actual status
OFF	X	X	X	X	X	OFF
ON	OFF	X	X	X	X	OFF
ON	ON	YES	OFF	X	X	OFF
			ON	NO	X	ON
				YES	OFF	OFF
				ON	ON	
		NO	X	NO	X	ON
				YES	OFF	OFF
					ON	ON
					ON	ON

The "X" means that whichever state doesn't affect the unit actual status.

## 9. Mode

This item displays the mode of the AHU, and the possible mode are cool/heat and Comfort/Economy/Boost, and it can be changed in [Settings](#) page.

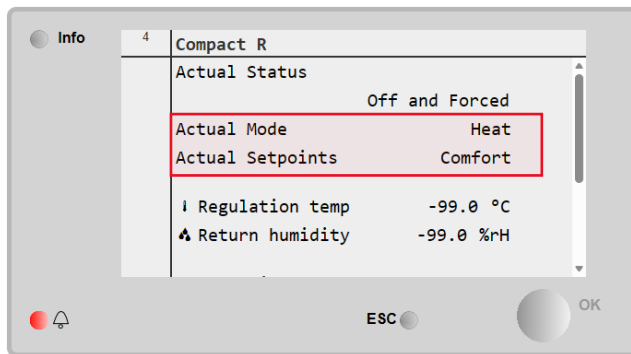

## 10. Regulation values

This item (read-only) displays the values used to regulate the AHU.

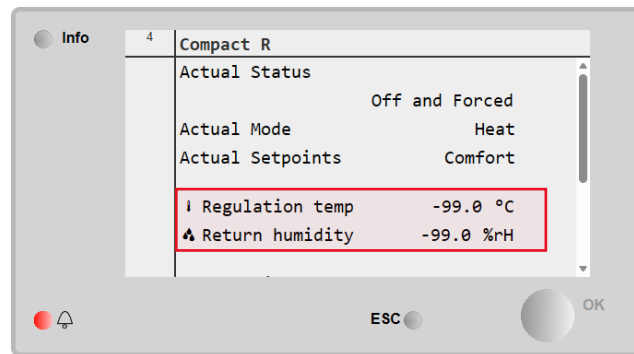

**HMI Path: Main page → Regulation temp**

The probe will monitor the temperature value, and the system will use the temperature to ensure the setpoint is maintained.

The system will be able to provide optimized commands to correct any deviation from the temperature set point with all the treatment systems envisaged, increasing or decreasing the signal sent to the treatment system.

The same applies to the return probe if selected as the control temperature.

## 11. HMI Switch

This item displays and allows you to set the status of the AHU.

**HMI Path: Main Menu → HMI Switch**

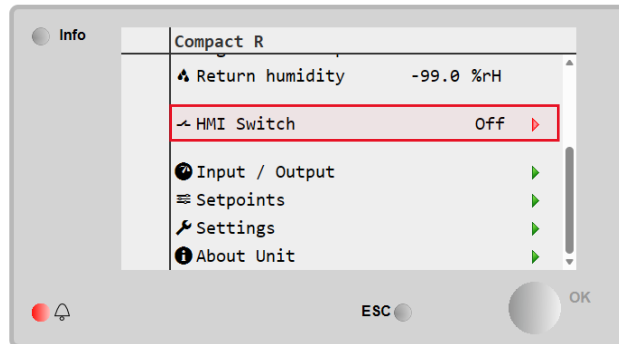

## 12. Input/Output

This menu (read-only) allows to access submenus of read values throughout the application.

**HMI Path: Main Menu → Input/Output**

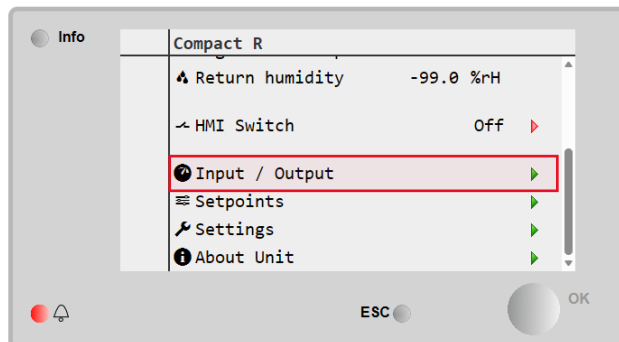

Selecting "Input/Output" a menu shows the access to sub menus dedicated to different signals of the system as explained below:

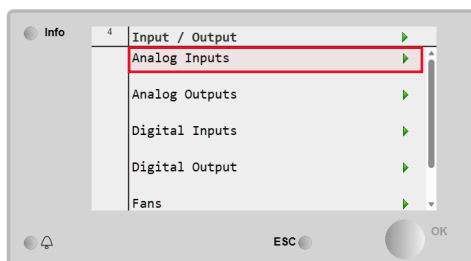

Select "Analog Inputs" to show probes and transducers values.

Scroll down to show remaining values: Temperatures, pressures, airflow, filters, recuperator, humidity, dew points, air quality and Modbus values.

Or

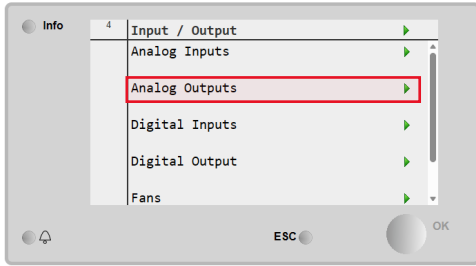

Select "Analog Outputs" to show coils, dampers, rotary, ERQ and fans signals.

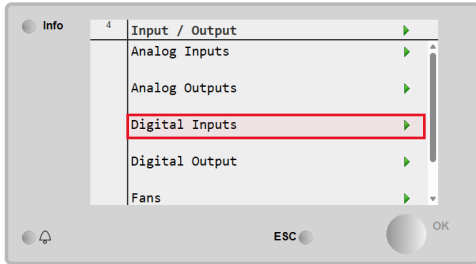

Select "Digital Inputs" to show alarms and switch status.

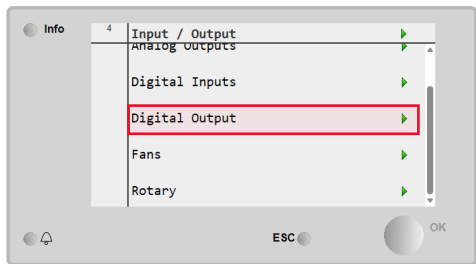

Select "Digital Outputs" to show command and switch.

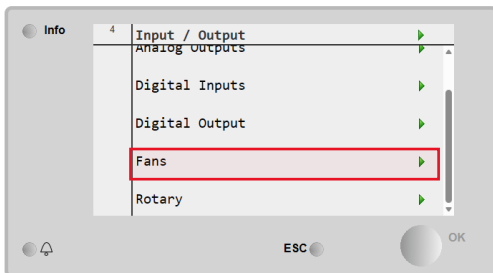

Select "Fans" to show the airflow, signals, power, actual speed for both supply and return fans.

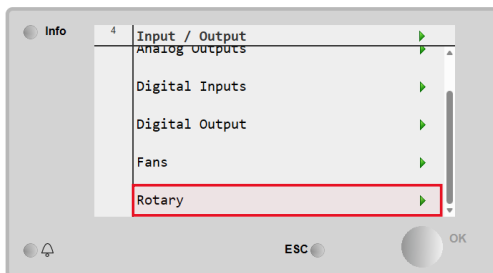

Select "Rotary" to show the signal, actual motor rotary speed, power, torque, current rms, internal temperature, purging interval and rotation, and the operating days and mins.

## 13. Setpoint

This menu allows the user to access all setpoints used to control AHU.

**HMI Path: Main Menu → Setpoints**

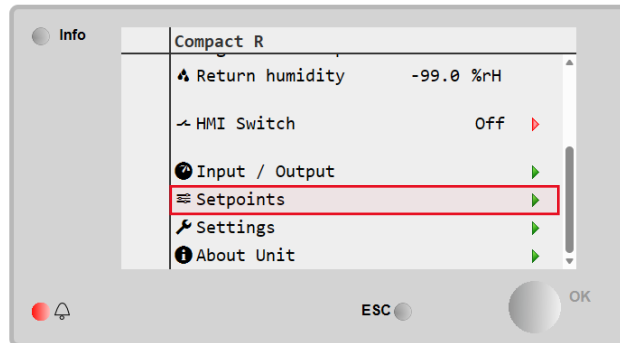

Selecting "Setpoints" a page allows to change all setpoints values, used by the system to target regulation algorithm.

### 13.1. Fans

To access all setpoints related to fan regulation

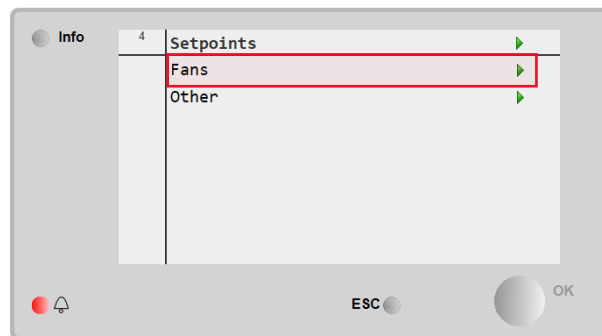

Active setpoints for regulation are displayed at the top page

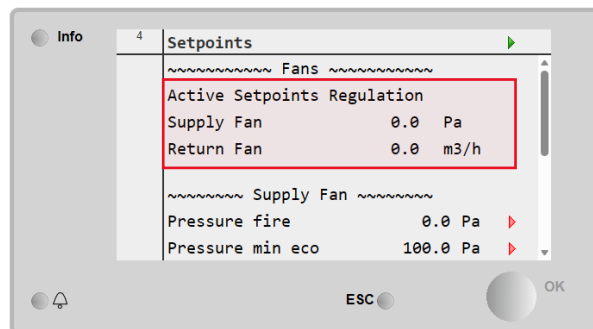

## 13.2. Others

The rest of the setpoints are available in the Other page

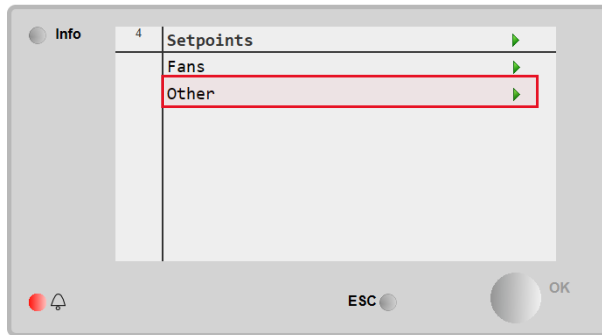

Active setpoints for regulation are displayed at the top page

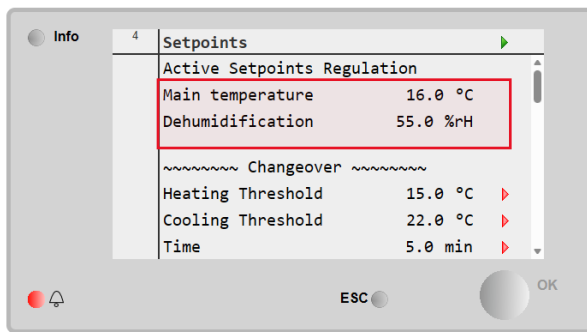

### 13.2.1 Filters alarm threshold

4 Setpoints	
~~~~~ Filters ~~~~~	
Warning threshold	
Return	150.0 Pa
Outdoor	150.0 Pa
Fault threshold	
Return	300.0 Pa
Outdoor	300.0 Pa

This setpoint is used to set the pressure difference you want to report on each activated filter. The first is just a warning, the second is a fault that stops the AHU.

14. Settings

This menu, up to the password level, allows the user to access submenus for communication channels.

HMI Path: Main Menu → Setting

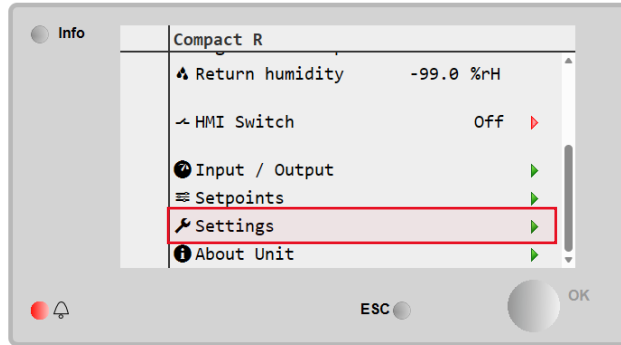

Selecting settings and logging in with needed password to access different menu as shown below:

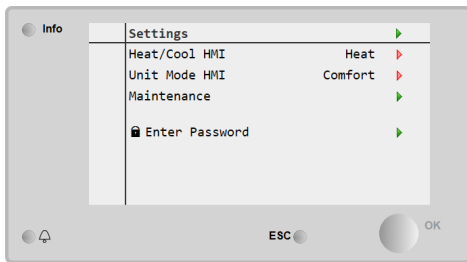

Menu with User level password.

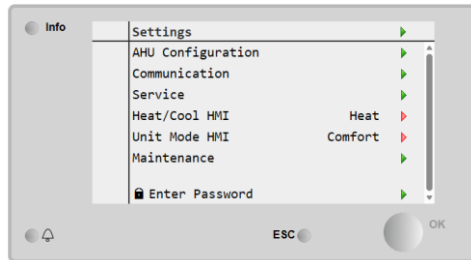

Menu with Maintenance level password.

14.1. Communication

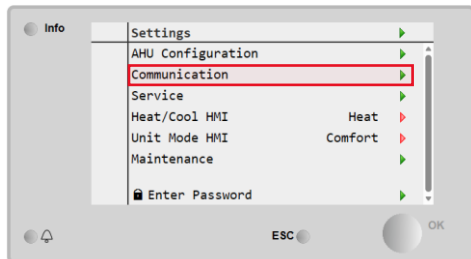

Select "Communication" to access different channel parametrization.

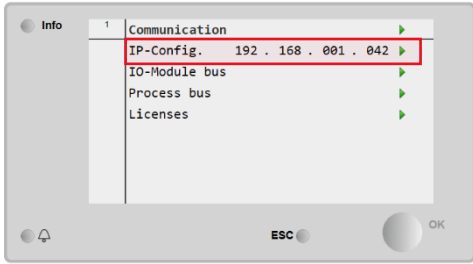

Select "IP-Config." to access configuration of IP address of the control system.

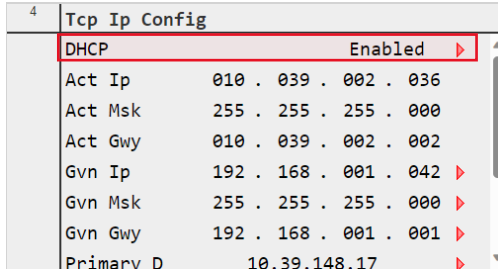

Select "DHCP" to enable or disable the service.

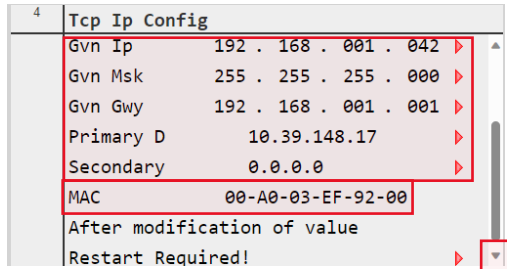

Scroll down to show remaining values. In case of DHCP disabled use Gvn (given) fields to assign specific IP values to the control system. MAC is the mac address of the POL688 (control system) of the unit.

14.1.1 Licenses

Enter the license key to enable the Modbus RTU/TCP, BACnet TCP

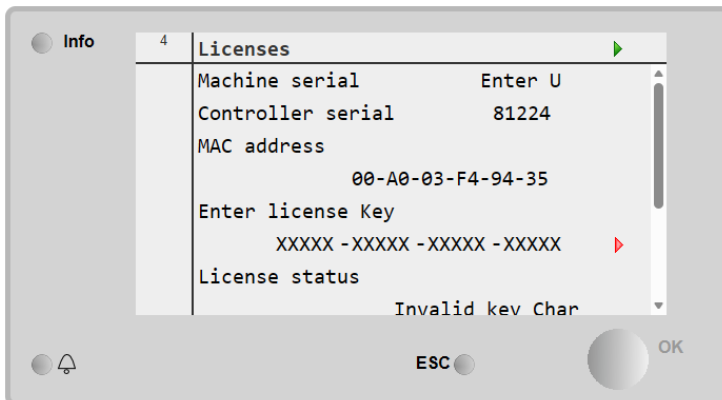

Once the License status shows "Valid key" then execute a restart, and based on the license key the communication module is activated

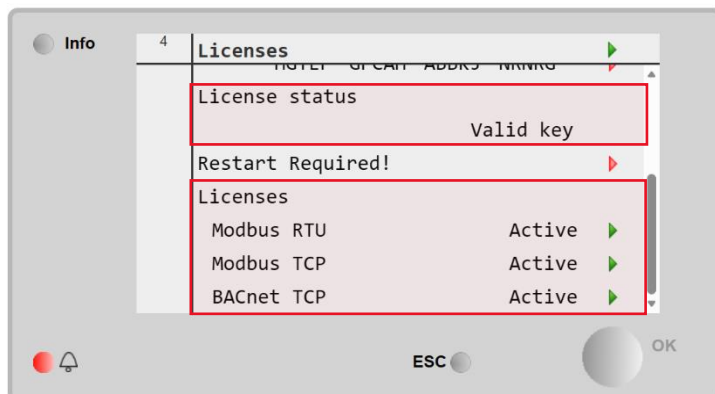

Enter inside each communication module and change its settings if necessary

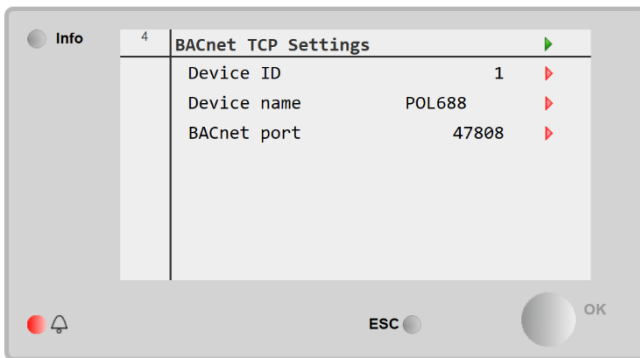
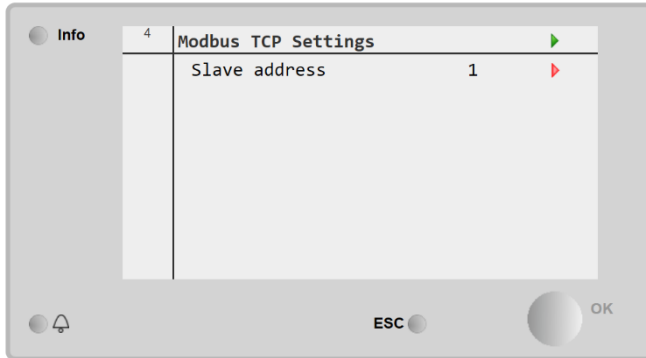
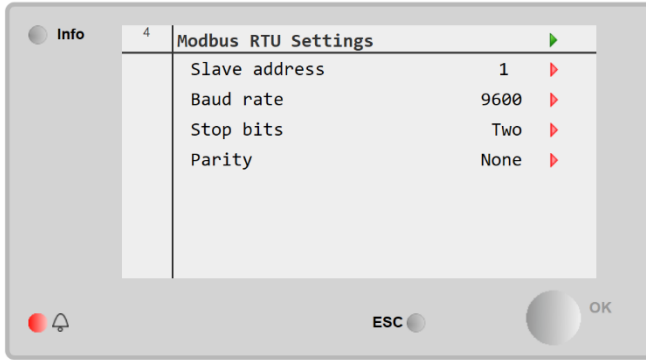

14.2. Maintenance

Maintenance page contains running time and alarms of all available fans and rotary
Notice that:

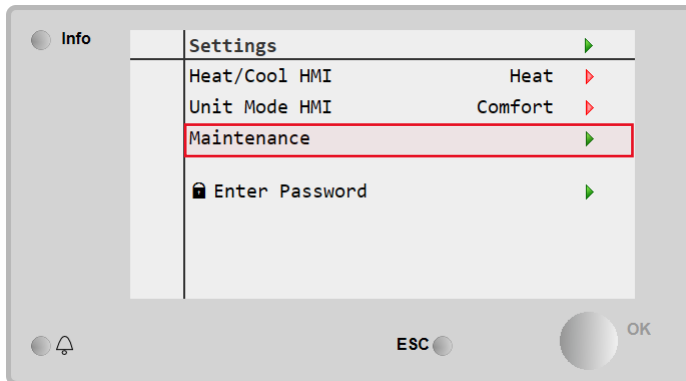

- No password level is required to visualize these pages

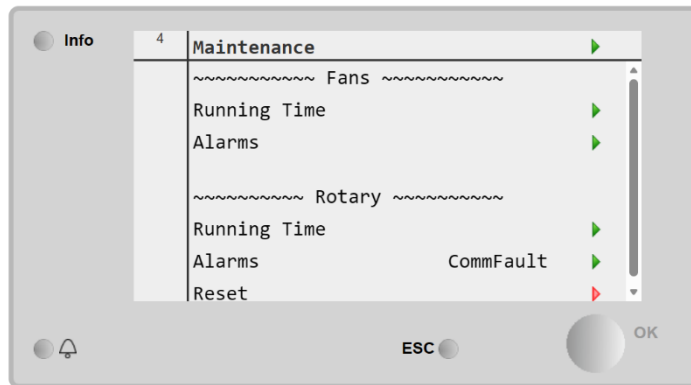

14.2.1 Fans

- Running Time

Maintenance – Fans - Running time page contains the running time of the AHU and each fan (in hours), with the possibility to reset the running time if needed.

Notice that:

- No password level is required to visualize the running time
- [Maintenance level](#) or higher level password is required to reset the running time

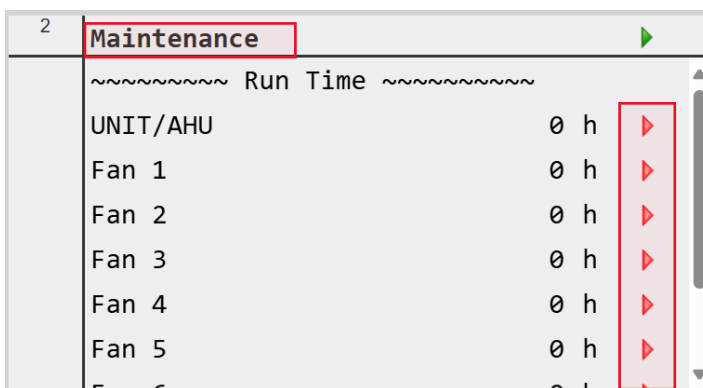

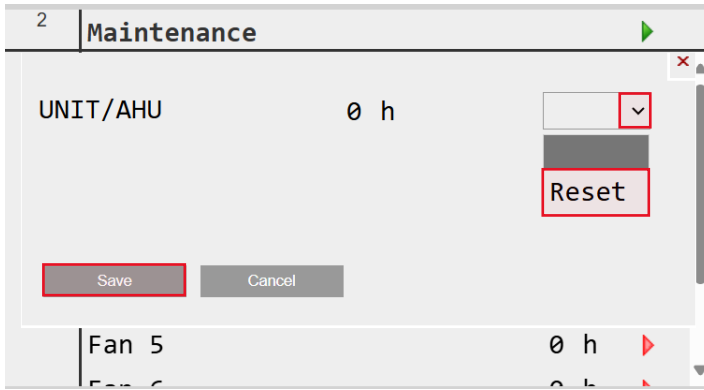

- Fan Alarms

Fan Alarms page contains general status of alarms and more details about the Motor status alarm, and Warning alarms inside each page for each fan

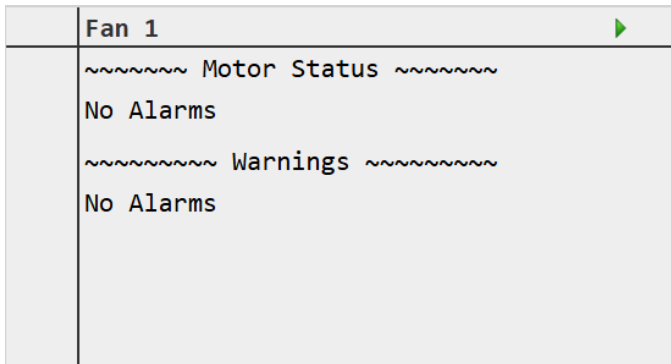
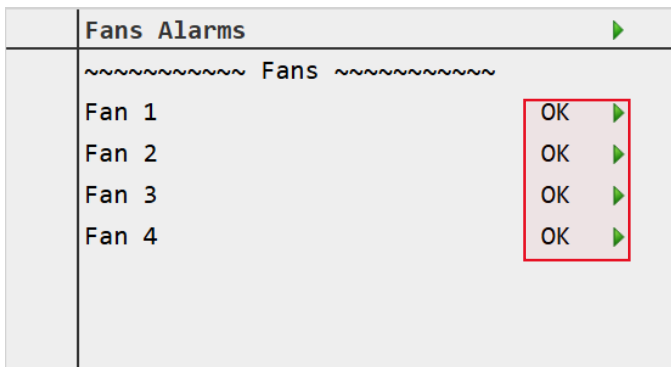

Notice that:

- If no alarm is present the fan alarm will be "OK" and "No Alarms" inside the fan alarm page
- A "Comm Fault" will appear if the fan is not properly communicating with the unit
- If there is any alarm present the fan alarm will be "FAULT" and reference alarm code inside the fan alarm page which can be referred to point 14.2.3

e.g. If Fan 1 alarm is in FAULT and inside its page the following alarms are observed, so with referring to point 14.2.3, TFE correspond to "Output stage overheated" and so on for the rest of the alarms

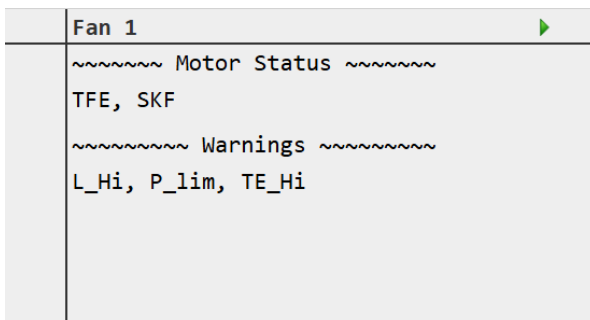

14.2.2 Rotary

- Running time

Maintenance – Rotary - Running time page contains the running time of the rotary (in days and minutes).

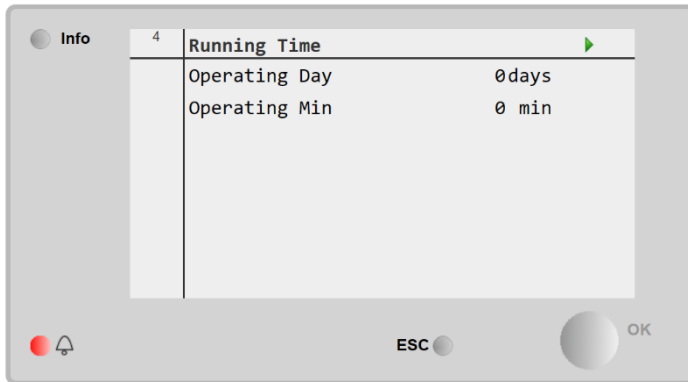

- Alarm

Rotary Alarms page contains general status of alarms

- If no alarm is present the rotary alarm becomes “OK” and “No Alarms” inside the rotary alarm page
- A “CommFault” appears if the rotary is not properly communicating with the unit
- If there is any alarm present the rotary alarm becomes “FAULT” and reference alarm code inside the rotary alarm page which can be referred to point 14.2.4
- Reset rotary alarm is available (require maintenance password level to be executed)

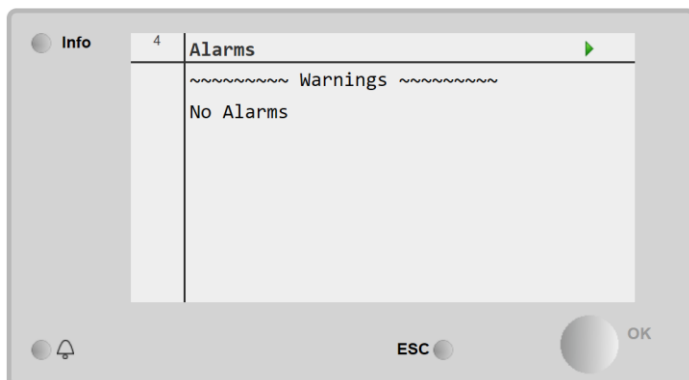
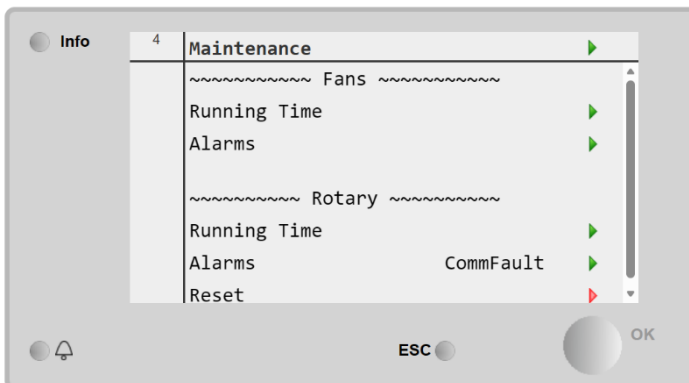

14.2.3 Fan reference alarm codes

Malfunction and service information

- Motor Status

- UzLow: DC-link undervoltage
- RL_Cal: Rotor position sensor calibration error
- n_Lim: Speed limit exceeded
- BLK: Motor blocked
- HLL: Hall sensor error
- TFM: Motor overheated
- FB: Fan Bad (general error)
- SKF: Communication error between master controller and slave controller
- TFE: Output stage overheated
- PHA: Phase failure (3-phase devices) or line undervoltage (single-phase devices)

- Warning

- ILim: Current limitation in action
- L_hi: Line impedance too high (DC-link voltage unstable)
- P_Lim: Power limiter in action
- TE_hi: Output stage temperature high
- TM_hi: Motor temperature high
- TEI_hi: Temperature inside electronics high
- UzLow: DC-link voltage low
- Braking: Braking mode: set in the case of external drive in opposite direction at high speed for lengthy period
- RLCal: Calibration of rotor position sensor in progress
- nLow: Actual speed is lower than speed limit for running monitoring
- OpnCir: Open circuit at analog input or PWM input for the set value (voltage at analog input < open circuit limit value - or signal at PWM input statically high)
- UzHi: DC-link voltage high
- UeHi: Line voltage high
- LRF: Shedding function active

14.2.4 Rotary reference alarm codes

Malfunction and service information

- RGA: Rotor guard alarm
- VLA: Voltage low alarm
- VHA: Voltage high alarm
- IHA: Current high alarm (Motor out short)
- TH: Temperature high warning
- OIL: Overload / current limit warning
- IS: Internal stop
- RB: Rotor blocked alarm
- EE: EEPROM error warning
- CEM: Communication error MOC alarm
- MPE: Motor phase error alarm
- RPL: Ripple warning
- MIB: MOC in bootloader alarm
- ICM: IO configuration mismatch warning

15. Service

From Settings you can enter to Service where you can access several services as

- Language Selection
- Main regulation
- Side regulation
- Daikin On Site
- Enabling BMS
- Time Scheduler
- Clock Settings

HMI Path: Main Menu → Settings → Service

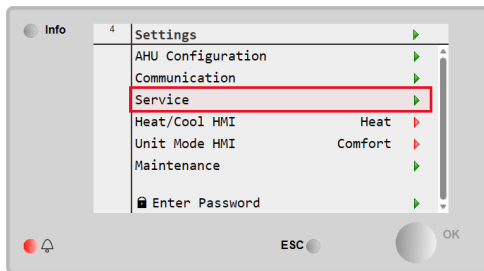

- Language Selection



Select "Language Selection" to change language of HMI if available.

- Main/Side Regulation

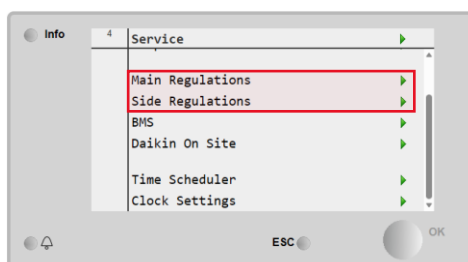

Select "Main Regulation/Side Regulation" to adjust the loop timing and control loop parameters.

- Enabling BMS

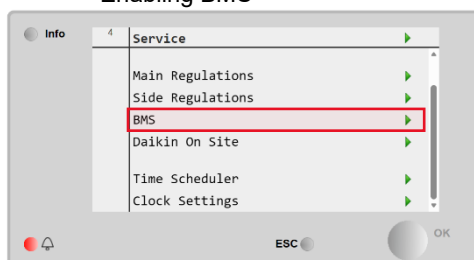

Select "Enable BMS" to access menu that Allow to enable or disable BMS functionality (Off / On of the unit).

- Daikin On Site



Select "Daikin On Site" to access cloud connection if available.

- Time Scheduler and Clock Settings

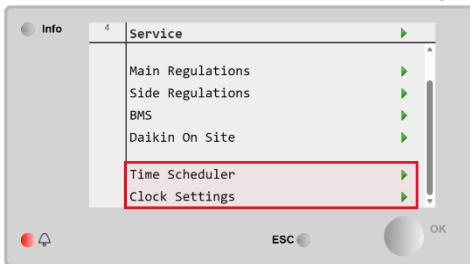

Select "Time Scheduler" and "Clock Settings" to program the start-up and shutdown of the unit by time slots and days of the week.

16. About Unit

This menu allows users to access pages with information about unit software.

HMI Path: Main Menu -> About unit

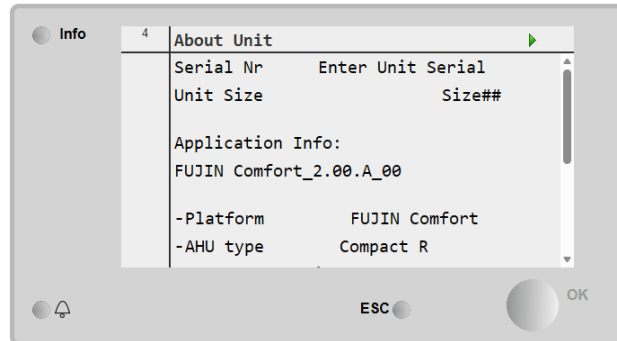

This page shows useful information to note while contacting service in case of need. Single information is explained below:

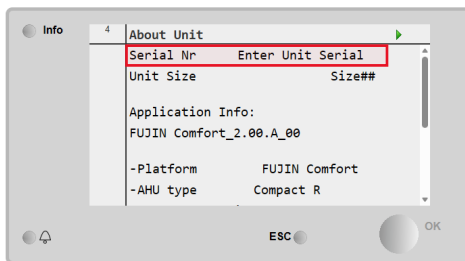

“Serial Nr” shows the specific serial number of the unit.

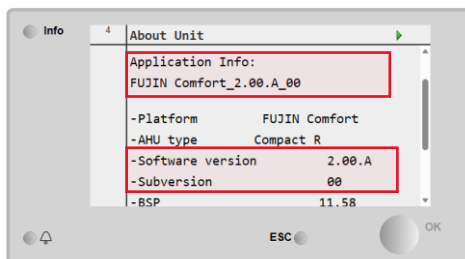

“Software version:” shows the application release running on the unit control system.

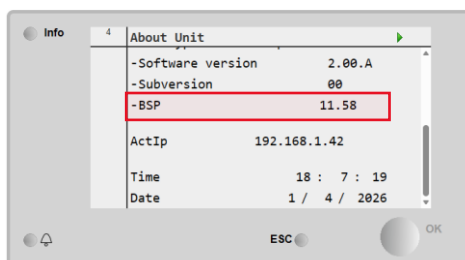

“BSP” shows the release of the operating system running on the unit control system.

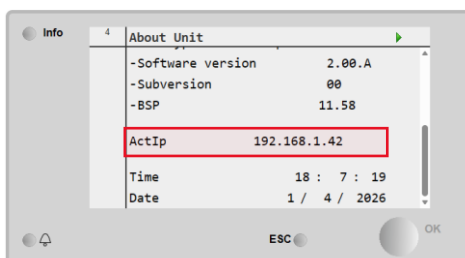

“Act IP” shows the actual IP address of the control system board.

17. Alarm

17.1. Alarm list

Alarms		Class	High Limit	Low Limit
Type	Name			
Digital Inputs	PreHeating electrical alarm	WA1		
	Combine pump alarm	WA1		
	ERQ alarm	WA1		
	Humidifier alarm	WA1		
	Fire alarm	FL1/WA1		
	Post heathing pump alarm	WA1		
	Post Heathing electrical alarm	WA1		
Analog inputs	Outdoor temperature	WA1	80 °C	- 20 °C
	Outdoor temperature optional	WA1	80 °C	- 20 °C
	Supply temperature	FL1/WA1	80 °C	- 20 °C
	Supply temperature optional	WA1	80 °C	- 20 °C
	Return temperature	WA1	80 °C	- 20 °C
	Exhaust temperature	WA1	1000 Pa	0 Pa
	Outdoor pre-filter optional pressure	WA1	1000 Pa	0 Pa
	Outdoor filter pressure	WA1	1000 Pa	0 Pa
	Supply fan pressure	FL1	1000 Pa	0 Pa
	Supply fan pressure optional	FL1	1000 Pa	0 Pa
	Return fan pressure optional	FL1	1000 Pa	0 Pa
	Supply filter pressure optional	WA1	1000 Pa	0 Pa
	Return filter pressure	WA1	1000 Pa	0 Pa
	Return fan pressure	FL1	1000 Pa	0 Pa
	Outdoor humidity	WA1	100 %r.H	0 %r.H
	Supply humidity	WA1	100 %r.H	0 %r.H
	Return humidity	WA1	100 %r.H	0 %r.H
	Return CO2	WA1	1950 ppb	0 ppb
COE	FAN	FL1		
	Rotary	FL1		

Legend		
WA1 =	Warning	The unit will continue to work by reporting the alarm.
FL1 =	Fault	The unit will stop operation as it is a critical alarm.

17.2. Alarm Reset

This menu allows the user to reset alarms once the problem is fixed.

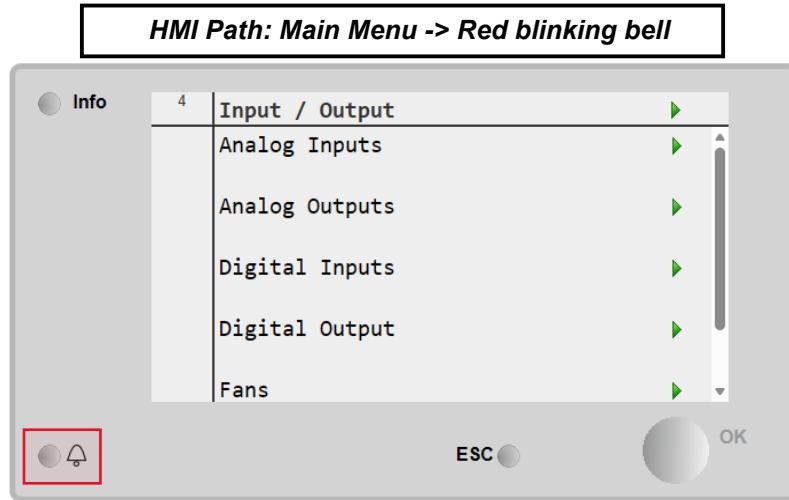

This page shows everything about the alarms and allows reset once the problem is fixed. To access the reset, you must enter one of the passwords described in the previous chapters.

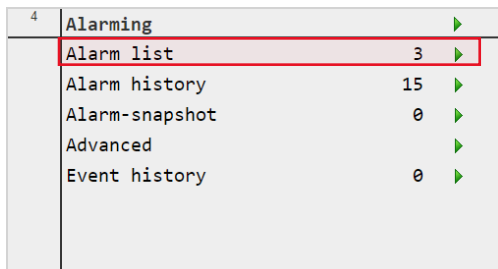

Select "Alarm list" to open the page where all the alarms are shown.

The number next to the green triangle means the number of alarms present.

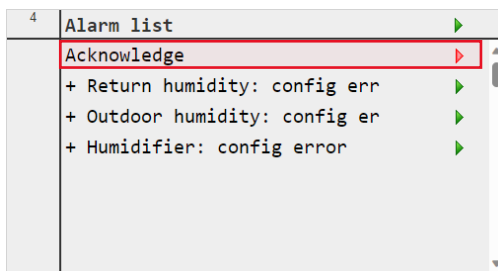

Select "Acknowledge" to open the page where you can execute the reset command select execute and press save.

([User password](#) level or above is required).

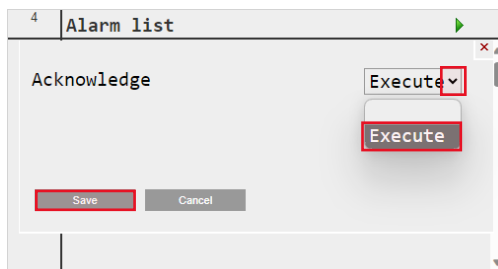

If the problem has been solved the alarm will disappear from the list.

Select "Alarm history" to view the list of actions taken for each alarm.

4	Alarming		▶
	Alarm list	3	▶
	Alarm history	15	▶
	Alarm-snapshot	0	▶
	Advanced		▶
	Event history	0	▶











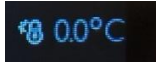

4	Alarm history		▶
	Entries	15	▶
	- Recovery pressure: OK		▶
	+ Return humidity: config err		▶
	+ Outdoor humidity: config er		▶
	+ Recovery pressure: com faul		▶
	+ Humidifier: config error		▶
	- Recovery pressure: OK		▶
	+ Recoverv pressure: com faul		▶

Scroll to view all list.

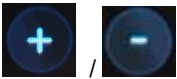
Appendix A

AUC00RT

Temperature, humidity & CO2	Temperature only
Always On Display (AOD) screen	
 <p>DAIKIN</p> <p>15 %rH 683 CO₂ ppm</p> <p>32.2 °C</p>	 <p>DAIKIN</p> <p>24.0 °C</p>
Main page	
 <p>DAIKIN 0.0°C</p> <p>16 %rH 684 CO₂ ppm</p> <p>31.7 °C</p>	 <p>DAIKIN 0.0°C</p> <p>24.0 °C</p> <p>+21.0</p>
Secondary page	
 <p>DAIKIN 0.0°C</p> <p>16 %rH 685 CO₂ ppm</p> <p>31.1 °C</p>	 <p>DAIKIN 0.0°C</p> <p>24.0 °C</p> <p>+21.9</p>

Display	Meaning	Unit	Action	Location
	Room Temperature	[°C]	Read only	All pages
	Room Humidity	[%rH]	Read only	All pages*
	Room Air Quality	[ppm]	Read only	All pages*
	Outdoor temperature	[°C]	Read only	Main/Secondary pages
	Navigate to different page	-	Write on press	Main/Secondary pages
	Unit status: OFF	OFF /ON/Ventilation	Read/Write multiple status on press	Main page
	Unit status: ON	OFF/ ON /Ventilation	Read/Write multiple status on press	Main page
	Unit status: Ventilation	OFF/ON/ Ventilation	Read/Write multiple status on press	Main page
	Increment/Decrement of the setpoint	Resolution of increment/decrement - Temperature: 0.1 [°C] - Humidity: 1 [%rH] - Air quality: 10 [ppm]	Write on press	Main/Secondary pages**
	Cooling mode	Cool /Heat	Read/Write on press	Secondary page
	Heating mode	Cool/ Heat	Read/Write on press	Secondary page
	Comfort mode	Comfort /Eco/Boost	Read/Write on press	Secondary page
	Eco mode	Comfort/ Eco /Boost	Read/Write on press	Secondary page
	Boost mode	Comfort/Eco/ Boost	Read/Write on press	Secondary page

*Available only with AUC00RT with humidity & CO2

** On AUC00RT with humidity & CO2, press on the reading values to get the Increment/Decrement buttons

The present publication is drawn up by of information only and does not constitute an offer binding upon DaikinApplied Europe S.p.A... Daikin Applied Europe S.p.A. has compiled the content of this publication to the best of its knowledge. No express or implied warranty is given for the completeness, accuracy, reliability or fitness for particular purpose of its content, and the products and services presented therein. Specification are subject to change without prior notice. Refer to the data communicated at the time of the order. Daikin Applied Europe S.p.A. explicitly rejects any liability for any direct or indirect damage, in the broadest sense, arising from or related to the use and/or interpretation of this publication. All content is copyrighted by Daikin Applied EuropeS.p.A..

DAIKIN APPLIED EUROPE S.p.A.
Via Piani di Santa Maria, 72 - 00040
Ariccia (Roma) - Italia Tel: (+39) 06 93
73 11 - Fax: (+39) 06 93 74 14
<http://www.daikinapplied.eu>